

& OPERATION MANUAL & PARTS LIST

Soosan Hydraulic Breaker

SB Series



Contents

OPERATION MANUAL

01. Safety Precautions	1
1.1 Safety Precautions	1
1.2 Sticker list & Placed on the Breaker	4
02. Standard Specification	16
03. External Dimension	20
3.1 Side Type	20
3.2 Backhoe Type	22
3.3 Top Type	24
3.3.1 Standard Top Type (Direct mounting)	24
3.3.2 Standard Top Type (Cap mounting)	25
3.3.3 TRENCH FINAL TYPE	26
3.3.4 TS-P Type	27
3.4 COVER PLATE(TS-P Type)	29
04. Preparation for Installation and Operation.	32
4.1 Checking before installation instructions	32
4.2 Installation and Removal	33
4.3 Hydraulic pipe lines for exclusive use	37
05. Precautions for safe operation.	38
06. Maintenance	44
07. Wear Tolerance	50
08. Inspection and Charging of N₂ Gas at Back head	56
09. Inspection and Charging of N₂ gas in Accumulator	58
10. Trouble Shooting	61
11. Hydraulic Oil	62
12. The Auto Lubrication Kit(Optional)	64
13. Underwater Operation of the Breaker(Optional)	69
01. Main Body	76
02. Seal kit	102
03. Cylinder Set	105
04. Front Head Set	110
05. Rod type	112
06. Side type	114
07. Backhoe type	119
08. Top type	126
8.1 Standard top type(Direct mounting)	126
8.2 Standard top type(Cap mounting)	128
8.3 Standard top type (TRENCH FINAL TYPE)	130
8.4 TS-P type	134
09. Oil Hose	144
10. Tool set (Option)	145
11. Back head gas charging kit (Option)	151
11.1 Back head gas charging kit 1(SB10Ⅱ ~ SB50)	151
11.2 Back head gas charging kit 2(SB60 ~ SB195H)	151
12. Accumulator charging tool set (Option)	152

PART BOOK

OPERATION MANUAL

Soosan Hydraulic Breaker



DANGER

SERIOUS INJURY OR DEATH COULD RESULT FROM THE IMPROPER REPAIR OR SERVICE OF THIS HYDRAULIC BREAKER. REPAIRS AND / OR SERVICE TO THIS HYDRAULIC BREAKER MUST ONLY BE DONE BY AN AUTHORIZED AND CERTIFIED DEALER.

Model	
Serial Number	
Year of Construction	

SOOSAN
HEAVY INDUSTRIES



EC Declaration of Incorporation
according to EC Machinery Directive 2006/42/EC

We herewith declare, Soosan Heavy Ind. Co., Ltd.
of
260, Jeongmunsongsan-ro, Yanggam-Myeon,
Hwaseong-Si, Gyunggi-Do,
Korea

that the following machine complies with the appropriate basic safety and health requirements of the EC Directive(2006/42/EC) based on its design and type, as brought into circulation by us. In case of alteration of the machine, not agreed upon by us, this declaration will lose its validity. The machinery is incomplete and must not be put into service until the machinery into which it is to be incorporated has been declared in conformity with the provisions of the Directive.

Technical documentation for the machinery is made by :

Place : Soosan Heavy Ind. Co., Ltd
260, Jeongmunsongsan-ro, Yanggam-Myeon, Hwaseong-Si, Gyunggi-Do, Korea
Position : Manager, R&D team

Name :

The technical documentation for the machinery is available from :

Name : SOOSAN HEAVY INDUSTRIES CO., LTD EUROPE
Adress : Ohmweg 18,3208 ke, Spijkenisse, Netherlands

Machine Description : Construction Machinery (not appendix IV)
(Hydraulic Breaker)

Machine Type :

Serial Number :

Applicable EC Directive : EC Machinery Directive (2006/42/EC)

Applicable Harmonized

Standards : EN ISO 12100-2010
EN474-1:2006/A4:2013

Applicable National Technical Standards And Specifications :

Weight(kg) :
Length(mm) :
Oil flow(ℓ /min) :
Operation Pressure(kg/cm^2):
Blows(bpm) :

Date/ Authorized Signature :

Title of Signatory :



DANGER

DO NOT OPERATE THE HYDRAULIC BREAKER UNLESS THE FOLLOWING SAFETY INSTRUCTIONS HAVE BEEN THOROUGHLY READ AND UNDERSTOOD!

READ THIS MANUAL BEFORE INSTALLING, OPERATING OR MAINTAINING THIS EQUIPMENT.

ANY OTHER LANGUAGE WILL BE SERVICED ON REQUEST.

- > Flying debris from the hydraulic breaker or other material may cause serious or fatal injury to the operator. Personal protection equipment must be used.
- > Flying debris hydraulic breaker or other materials may cause serious or fatal injury to bystanders. Never operate the grab when bystanders are in the working area.
- > On machines/carriers, the hydraulic breaker can enter the operator's compartment under specific hydraulic breaker position. Make sure that suitable impact shields are used when operating the hydraulic breaker with this type of equipment.
- > Do not operate the breaker unless all safety decals described in this manual are in place. The decals must be inspected periodically to ensure that all wording is legible. The decals must be replaced if illegible. Replacement decals can be obtained from your authorized Soosan Distributor.
- > The hydraulic breaker will become very hot during operation. Allow time for hydraulic breaker to cool down before touching hydraulic breaker parts.

If this machine is transferred, be sure to attach this manual to the machine.

For safety, common items are described "SAFETY PRECATUIONS", and others are mentioned in the succeeding pages.

PREFACE

We appreciate your purchasing a Soosan Hydraulic Breaker. The Hydraulic Breaker, designed and built to provide durable operation under any working conditions, has been developed by Soosan's excellent engineering techniques with accumulated experiences for many years. Without proper handling, regular inspection and maintenance, however, the machine fails to display its full capacity, resulting in various troubles of machine parts.

This publication should be carefully read prior to installation and operation in order to prevent any mishandling of hydraulic breaker.

We guarantee that a faithful compliance of the instruction will contribute to the best operation condition.

Customers are, therefore, required to keep in mind that the company is not responsible for troubles caused by not following our guidelines or not using genuine parts.

“Translation of the original instruction”

01. Safety Precautions

1.1 Safety Precautions

This manual contains safety, operation, and routine maintenance instructions. It doesn't contain service disassembly and service assembly instructions. If needed, complete service disassembly and service assembly instructions are contained in manual which can be ordered from your Soosan Hydraulic Breaker authorized and certified dealer.

Please read the following warning.



Serious injury or death could result from the improper repair or service of this breaker. Repairs or service to this breaker must only be done by an authorized and certified dealer.

Most of the accidents are caused by disregarding the basic rules of operation inspection or repair, or by neglecting the inspection before operation. Many accidents can often be avoided by recognizing potentially hazardous situations before an accident occurs. Before operating, inspecting or repairing this machine, be sure to read and fully understand the preventive methods and warnings described on the machine or in this manual. If not, never operate, inspect or repair this machine

Safety labels and messages are classified as follows so that the users can understand the warnings on the machine or in this manual.



Indicates an imminently hazardous situation which, if not avoided, will result in death or serious injury. This signal word is to be limited to the most extreme situations



Indicates a potentially hazardous situation which, if not avoided, could result in death or serious injury.



Indicates a potentially hazardous situation which, if not avoided, may result in minor or moderate injury, It may also be used to alert against unsafe practices.

NOTICE

Signs used to indicate a statement of company policy directly or indirectly related to the safety of personal or protection of property.

The safety messages including the preventive measures to avoid danger.

For safety, common items are described in "SAFETY PRECAUTIONS", and others are mentioned in the succeeding pages.

Soosan cannot anticipate every possible circumstance that might involve a potential hazard on operation, inspection or repair. Therefore the warnings in this manual are not all inclusive. If an operation, inspection or repair not described in this manual is used, you must take measures for safety by yourself.



Observe the cautions and take a preventive measure for safety

The Soosan Hydraulic Breaker will provide safe and dependable service if operated in accordance with the instructions given in this manual. Read and understand this manual, any decals and tags attached to the breaker before operation. Failure to do so could result in personal injury or equipment damage

- Operate the breaker in accordance with all laws and regulations which affect you, your equipment, and the worksite.
- Do not operate the breaker until you have read this manual and thoroughly understood all safety, operation and maintenance instructions.
- Do not operate the breaker until you have read the carrier equipment manual and thoroughly understood backhoe or excavator or similar equipment used to operate the breaker. The word "carrier", as used in this manual, means a backhoe or excavator or similar equipment used to operate the breaker.
- Ensure that all maintenance procedures recommended in this manual are completed before using the equipment.
- The operator must not operate the breaker or carrier if any people are within the area where they may be injured by flying debris or movement of the equipment.
- Know the limits of your equipment.
- Before starting a work, Check the prohibitions, cautions and working processes in a working site with the field overseer, Observe all of them strictly.
- Wear such protective tools as a helmet, safety shoes, etc. to perform a work.
Make use of the protective glasses, earplugs, gloves and other protective tools if necessary.
- Establish a training program for all operators to ensure safe operation. Do not operate the breaker unless thoroughly trained or under the supervision of an instructor. Become familiar with the carrier controls before operating carrier and breaker. While learning operate the breaker and carrier, do so at a slow pace. If necessary, set the carrier to the slow position.
- Make sure all controls (levers and pedals) are in the neutral position before starting the carrier.
- Before leaving the carrier, always lower the boom and insure the carrier is stable. Never leave the machine with the engine running. Always engage the parking brake.
- Stop the engine before attempting to make any repairs, adjustments or servicing to either the carrier or the breaker.
- Do not operate the breaker at oil temperature above 175°F/80°C. Operation at higher temperature can damage the internal components of the breaker and carrier and will result in reduced breaker performance.
- Do not operate a damaged, leaking, improperly adjusted, or incompletely assembled breaker.

- Do not modify this breaker in any manner.
- Use only breaker parts manufactured by Soosan. Usage of breaker rod produced by another manufacturer may damage the breaker and will void the warranty.
- To avoid personal injury or equipment damage, all breaker repair, maintenance and service must only be performed by authorized and properly trained personnel.
- If you do not understand how to operate safely your breaker, contact an authorized Soosan Dealer for assistance.
- Keep this manual with the breaker.
- Do not operate this equipment if you are taking medication which may affect your mental judgement or physical performance.
- Do not operate this equipment if you are under the influence of drug or alcohol.
- Remove breaker from carrier during transportation.

1.2 Sticker list & Placed on the Breaker

■ Warning sticker (C03 192)

- 1) Use hearing protection
- 2) Use eye protection
- 3) Use breathing protection
- 4) Use the manual before use

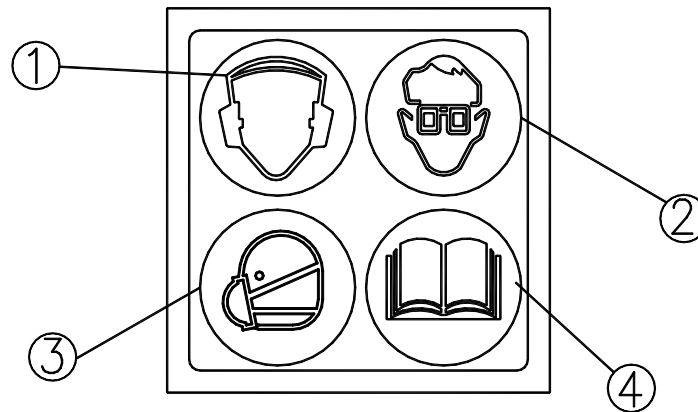

■ Greasing Sticker (SOOSAN D83 168)

GREASING



1. Use the recommended grease.
2. Grease whenever the Rod looks dry.
3. Failure to comply with these instructions, can result in damage to Rod and rod bushes and will void the warranty.

■ Specification Plate (For Example SB130)

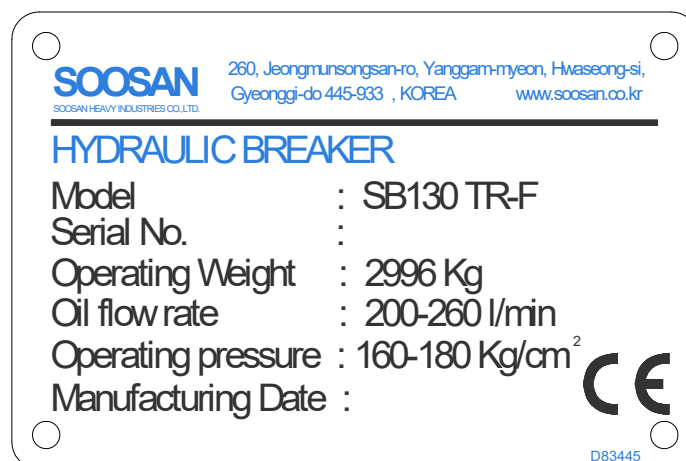

■ SB43B SIDE SILENCED BACKHOE

NO.	1	3	4	5	6	7	8	9	10	11
MODEL	BI Sticker (R)	Name Plate	Back Head	Greasing	Warning	Danger	Noise	BI Sticker (L)	Acc' Sticker (A)	Acc' Sticker (B)
SB43B (F93654)	F93655	F93657	F93264	D83168	D83166	E83210	F93262	F93656	C62212	F93263

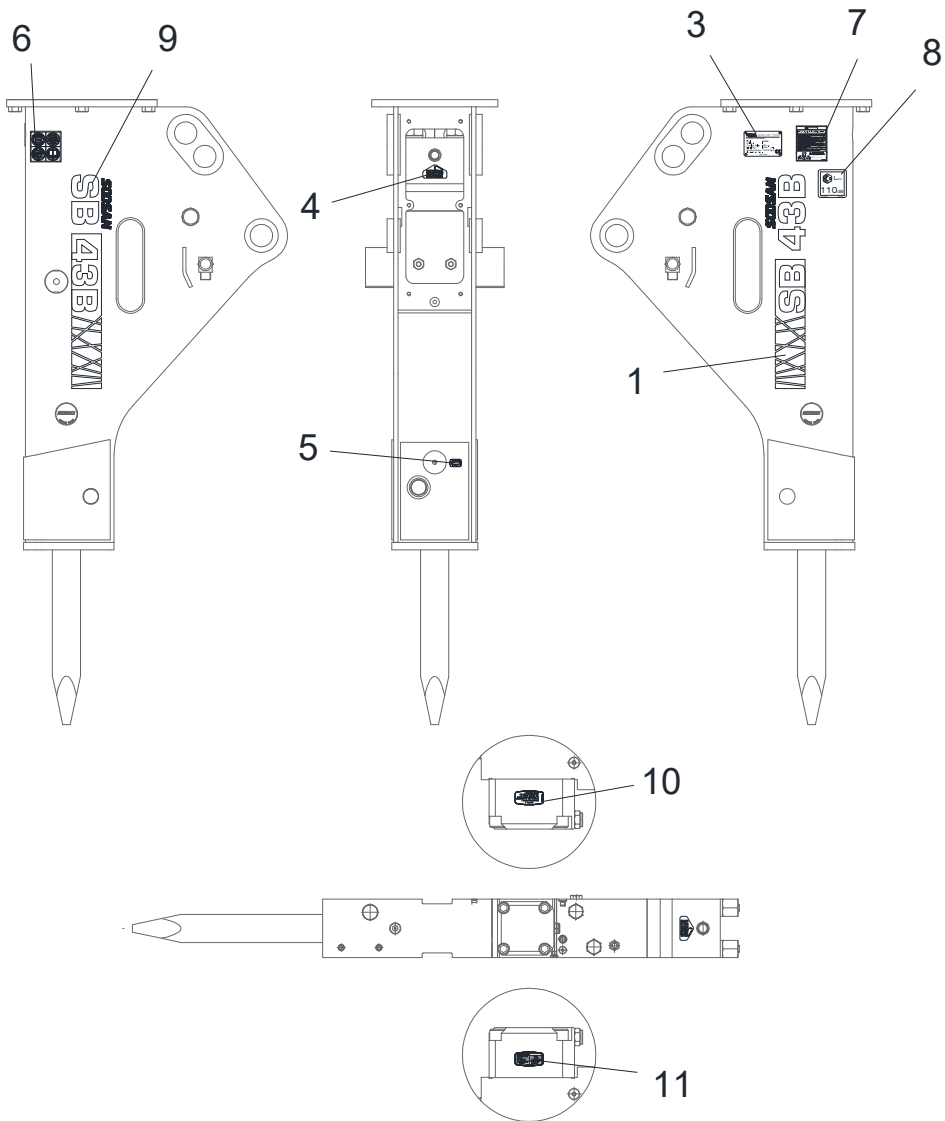

■ SB10II~SB50 TOP (Cap mounting)

NO.	1	2	4	5	6	7	8
MODEL	BI Sticker (R)	Name Plate	Back Head	Greasing	Danger	Warning	BI Sticker (L)
SB10II (E83601)	E83602	E83604	E83144	D83168	E83210	E83211	E83603
SB20II (F03601)	F03602	F03604	E83144	D83168	E83210	E83211	F03603
SB30II (E73327)	E73328	E73330	E83144	D83168	E83210	E83211	E73329
SB35II (F83601)	F83602	F83604	E83144	D83168	E83210	E83211	F83603
SB40II (C03617)	C03618	C03620	E83144	D83168	E83210	E83211	C03619
SB43II (F93628)	F93629	F93631	E83144	D83168	E83210	E83211	F93630
SB45 (D43601)	D43602	D43604	E83144	D83168	E83210	E83211	D43603
SB50 (C13609)	C13610	C13612	E83144	D83168	E83210	E83211	C13611

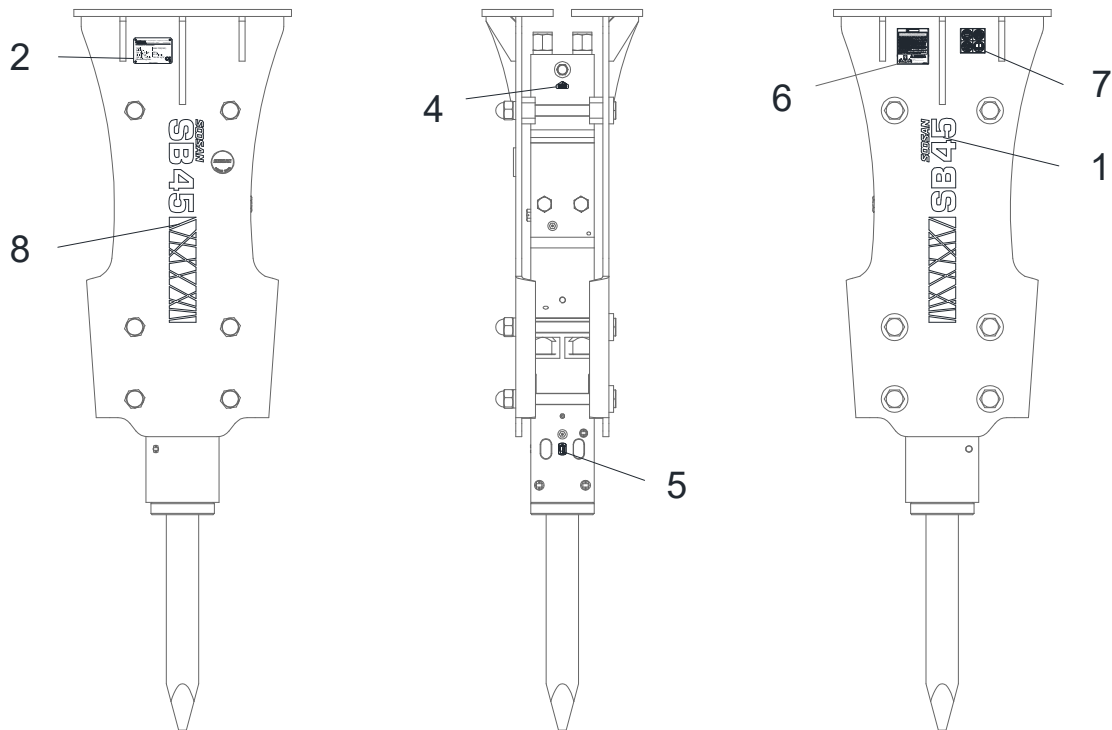

■ SB10II~SB50 TOP (Direct mounting)

NO.	1	2	4	5	6	7	8
MODEL	BI Sticker (R)	Name Plate	Back Head	Greasing	Danger	Warning	BI Sticker (L)
SB10II (E83605)	E83602	E83606	E83144	D83168	E83210	E83211	E83603
SB20II (F03605)	F03602	F03606	E83144	D83168	E83210	E83211	F03603
SB30II (E73331)	E73328	E73332	E83144	D83168	E83210	E83211	E73329
SB35II (F83605)	F83602	F83606	E83144	D83168	E83210	E83211	F83603
SB40II (C03621)	C03618	C03622	E83144	D83168	E83210	E83211	C03619
SB43II (F93632)	F93629	F93633	E83144	D83168	E83210	E83211	F93630
SB45 (D43605)	D43602	D43606	E83144	D83168	E83210	E83211	D43603
SB50 (C13613)	C13610	C13614	E83144	D83168	E83210	E83211	C13611

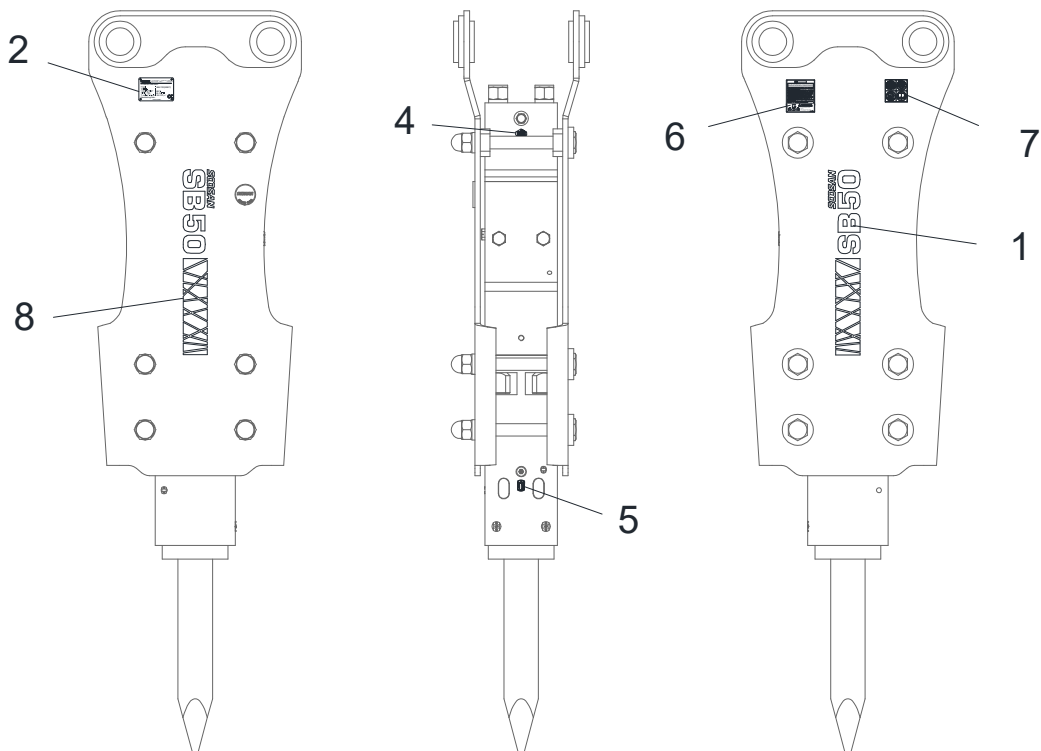

■ SB50~SB151 TR-F

NO. MODEL	1 BI Sticker (R)	2 Model Sticker	4 Name Plate	5 Back Head	6 Greasing	7 Acc' Sticker (A)	8 Acc' Sticker (B)	9 Danger	10 Warning	11 BI Sticker (L)
SB50 (C13623)	C23564	C13624	C13625	E83144	C01167	-	-	E83210	E83211	C23565
SB60 (C23589)	C23564	C23590	C23591	C02135	C01167	-	-	Q53134	D83166	C23565
SB70 (L03391)	L03314	L03392	L03393	C02135	C01167	-	-	Q53134	D83166	L03315
SB81 (C36041)	C23564	C36042	C36043	C02135	C01167	-	-	Q53134	D83166	C23565
SB81A (C36048)	C23564	C36049	C36050	C02135	C01167	C62212	C62213	D83167	D83166	C23565
SB100 (E93498)	C23564	E93499	E93500	C02135	C01167	C62212	C62213	Q53134	D83166	C23565
SB121 (C63603)	C63558	C63604	C63605	C02135	C01167	C62212	C62213	Q53134	D83166	C63559
SB130 (D83469)	D83448	D83470	D83471	C02135	C01167	C62212	C62213	Q53134	D83166	D83449
SB140 (L23357)	D83448	L23358	L23359	C02135	C01167	C62212	C62213	Q53134	D83166	D83449
SB151 (C73658)	D83448	C73659	C73660	C02135	C01167	C62212	C62213	D83167	D83166	D83449

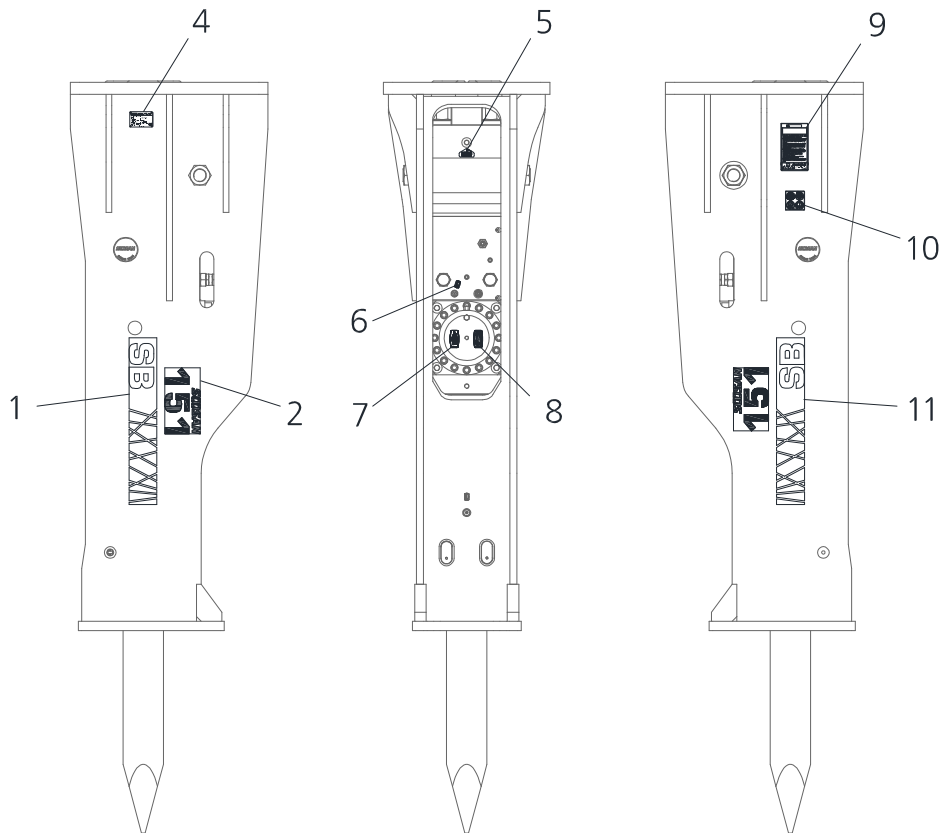

■ SB147,SB157,SB160 TR-F

NO.	1	3	4	5	6	7	8	9	10	11
MODEL	BI Sticker (L)	Spec Plate	Lifting Sticker	Greasing	Acc' Sticker (A)	Acc' Sticker (B)	Back Head	Warning	Danger	BI Sticker (R)
SB147 (T53123)	T53120	T53124	C23344	D83168	L53124	C73530	L52172	D83166	Q53134	T53121
SB157 (T73126)	T73123	T73127	C23344	D83168	L53124	C73530	L52172	D83166	Q53134	T73124
SB160 (T63120)	T63117	T63121	C23344	D83168	L53124	C73530	L52172	D83166	Q53134	T63118
SB177 (B0006422)	B0006423	B0006425	C23344	C01167	L53124	C73530	L52172	D83166	Q53134	B0006424

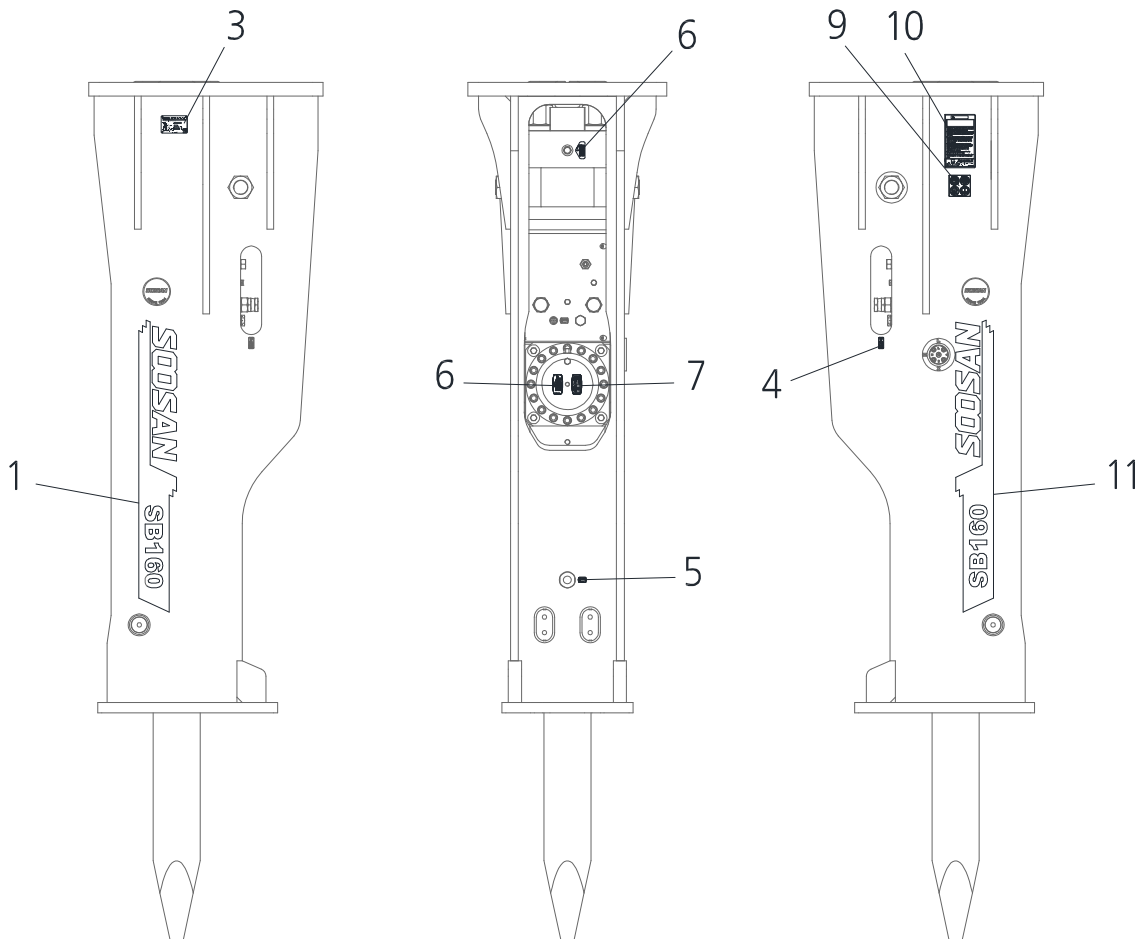

■ SB10TS-P~SB50TS-P

MODEL	NO.	1	2	4	5	6	7	8	9	10	11	12	13
		BI Sticker (R)	Model	Name Plate	Soosan Logo	Auto Greasing Sticker	Lifting Sticker	Greasing Sticker	Back Head Sticker	Warning Sticker	Noise Sticker	Danger Sticker	BI Sticker (L)
SB10II (E83619)	E83219	E83620	E83621	E83618	-	C23344	D83168	E83144	E83211	E83210	E83223	E83220	
SB20II (F03618)	E83219	F03619	F03620	E83618	-	C23344	D83168	E83144	E83211	E83210	F03225	E83220	
SB30II (E73344)	E73306	E73345	E73346	E83618	-	C23344	D83168	E83144	E83211	E83210	E73310	E73307	
SB35II (F83618)	E73306	F83619	F83620	E83618	-	C23344	D83168	E83144	E83211	E83210	F83240	E73307	
SB40II (C03634)	E73306	C03635	C03636	E83618	-	C23344	D83168	C02135	E83211	E83210	C03476	E73307	
SB43II (F93646)	F93286	F93647	F93648	F93645	-	C23344	D83168	C02135	E83211	F93290	E83210	F93287	
SB45 (D43618)	D43339	D43619	D43620	F93645	D83170	C23344	D83168	C02135	D83166	D43343	E83210	D43340	
SB50 (C13634)	C23564	C13624	C13635	F93645	D83170	C23344	D83168	C02135	E83211	C13471	Q53134	C23565	

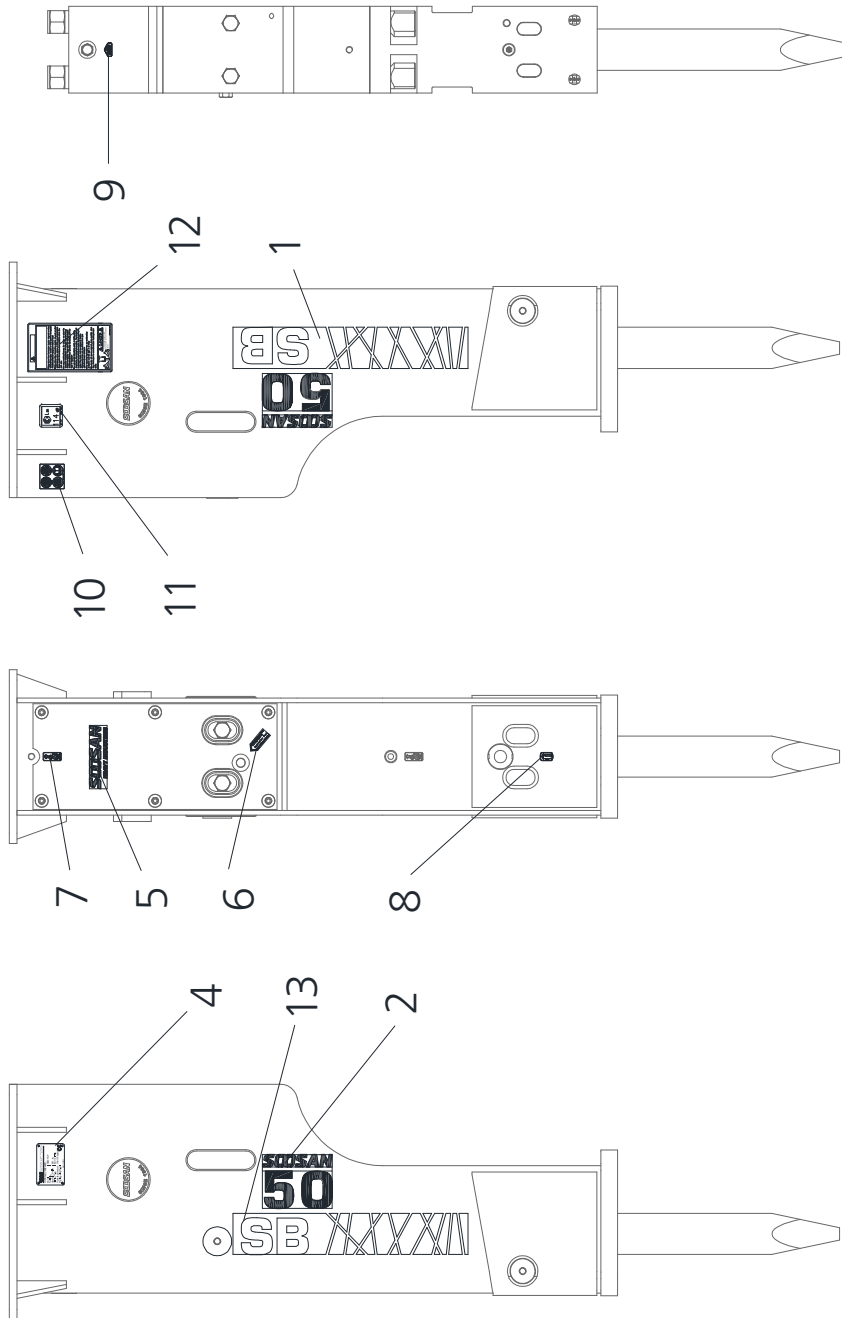

■ SB60TS-P~SB151TS-P

NO.	1	2	3	5	6	7	8	9	10	11	12	13	14	15
MODEL	BI Sticker (R)	Model Sticker	Name Plate	Soosan Logo Sticker	Auto Greasing Sticker	Lifting Sticker	Greasing Sticker	Back Head Sticker	Acc' Sticker (A)	Acc' Sticker (B)	Warning Sticker	Noise Sticker	Danger Sticker	BI Sticker (L)
SB60 (C23598)	C23564	C23590	C23599	F93645	D83170	C23344	D83168	C02135	-	-	D83166	C23567	Q53134	C23565
SB70 (L03402)	L03314	L03392	L03403	F93645	D83170	C23344	D83168	C02135	-	-	D83166	L03317	Q53134	L03315
SB81 (C36057)	C23564	C36042	C36058	F93645	D83170	C23344	D83168	C02135	-	-	D83166	C33891	Q53134	C23565
SB81A (C36062)	C23564	C36049	C36063	F93645	D83170	C23344	D83168	C02135	C62212	C62213	D83166	C33893	Q53134	C23565
SB100 (E93508)	C23564	E93499	E93509	F93645	D83170	C23344	D83168	C02135	C62212	C62213	D83166	E93430	Q53134	C23565
SB121 (C63619)	C63558	C63604	C63620	F93645	D83170	C23344	D83168	C02135	C62212	C62213	D83166	C63561	Q53134	C63559
SB130 (D83478)	D83448	D83470	D83479	F93645	D83170	C23344	D83168	C02135	C62212	C62213	D83166	D83451	Q53134	D83449
SB140 (L23366)	D83448	L23358	L23367	F93645	D83170	C23344	D83168	C02135	C62212	C62213	D83166	L23286	Q53134	D83449
SB151 (C73667)	D83448	C73659	C73668	F93645	D83170	C23344	D83168	C02135	C62212	C62213	D83166	C73572	Q53134	D83449

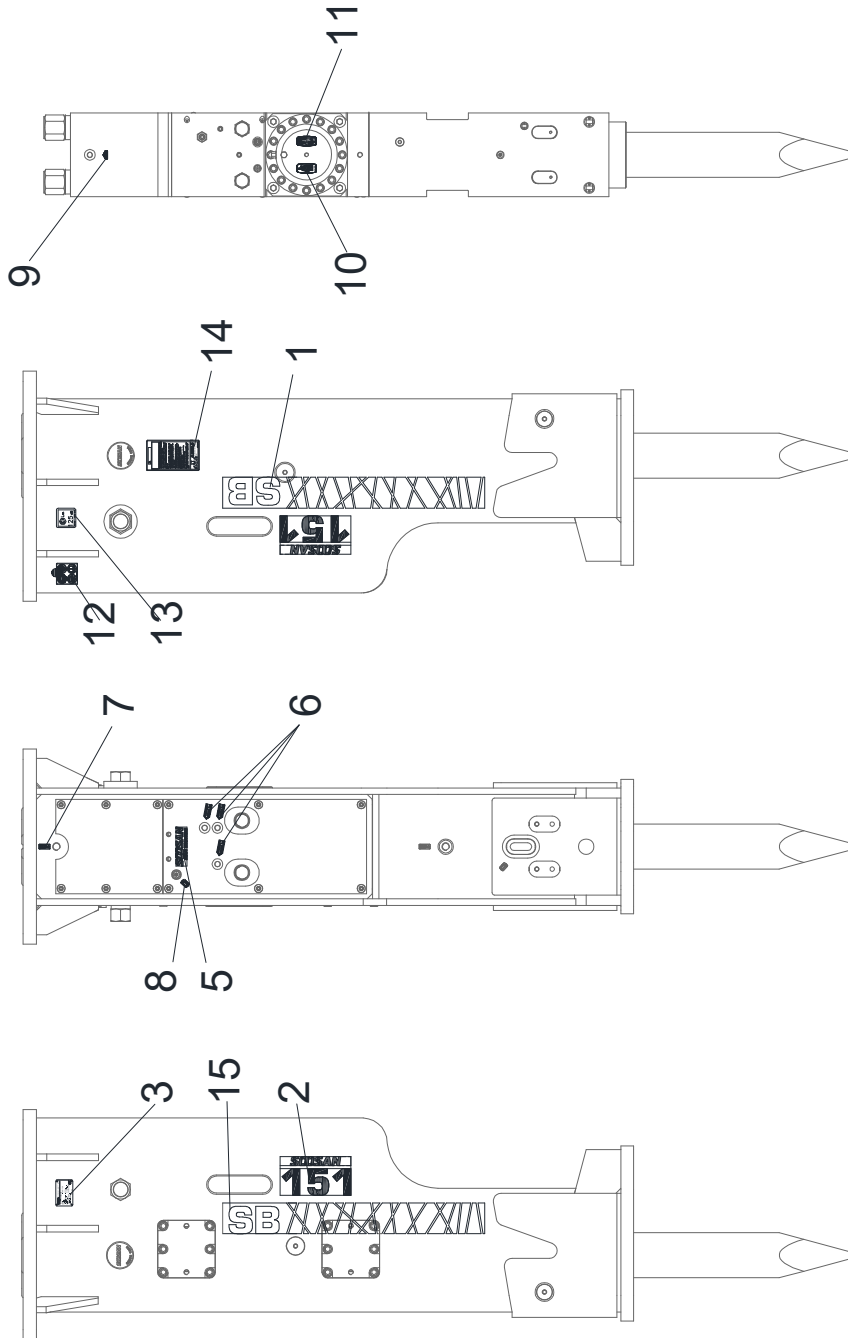

■ SB147, SB160 TS-P

NO.	1	2	4	5	6	7	8	9	10	11	12	13	14
MODEL	BI Sticker (R)	Spec Plate	Soosan Logo Sticker	Auto Greasing Sticker	Lifting Sticker	Greasing Sticker	Back Head Sticker	Acc' Sticker (A)	Acc' Sticker (B)	Warning Sticker	Noise Sticker	Danger Sticker	BI Sticker (L)
SB147 (T53127)	T53128	T53130	F93645	D83170	C23344	D83168	C02135	C62212	C62213	D83166	L23286	Q53134	T53129
SB157 (T73128)	T73129	T73131	F93645	D83170	C23344	D83168	C02135	C62212	C62213	D83166	C73572	Q53134	T73130

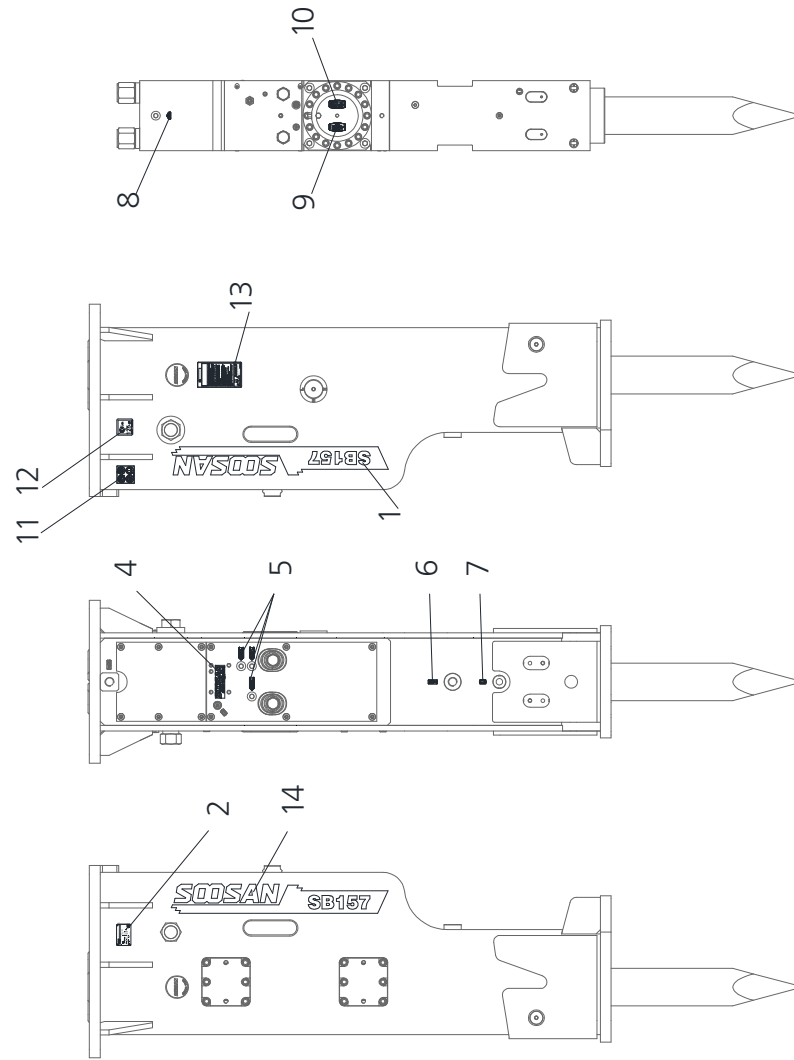

Local safety regulations.

Enter any local safety regulation here, keep these instructions in an area accessible to the operator and maintenance personnel.

02. Standard Specification

DESCRIPTION		UNIT	MODEL								
			SB10 II	SB20 II	SB30 II	SB35 II	SB40 II	SB43 II	SB45	SB50	
Body Weight	Including Rod	kg	53	65	88	127	151	208	278	471	
		lb	117	143	194	280	333	459	613	1038	
Operating Weight	Side Type	kg	70	90	120	180	250	380	510	765	
		lb	154	198	265	397	551	838	1124	1687	
	Top Type	Direct	kg	73	100	120	189	234	375	496.2	743
			lb	161	220	265	417	515.8	827	1093	1638
		Cap	kg	90	110	135	204	292	370	580	839
			lb	198	244	298	450	644	815	1279	1849.6
		TS-P	kg	102	126	152	224	295	375	571	861
			lb	225	278	335	494	650	827	1259	1898
	TR-F	kg	-	-	-	-	-	-	-	-	973
		lb	-	-	-	-	-	-	-	-	2145
Length	Side Type	mm	972	1071	1147	1239	1349	1618	1827	1934	
		in	38.3	42.2	45.2	48.8	53.1	63.7	71.9	76.1	
	Top Type	Direct	mm	1072	1190	1287	1382	1616	1849	2024	2150
			in	42.2	46.9	50.7	54.4	63.6	72.8	79.7	84.6
		Cap	mm	1150	1254	1313	1452	1602	1869	2225	2358
			in	45.3	49.4	51.7	57.2	63.1	73.6	87.6	92.8
		TS-P	mm	1135	1213	1317	1472	1620	1899	2161	2316
			in	44.7	47.8	51.9	58.0	63.8	74.8	85.0	91.2
	TR-F	mm	-	-	-	-	-	-	-	-	2325
		in	-	-	-	-	-	-	-	-	91.5
Width	Side Type	mm	192	191	203	247	270	315	394	408	
		in	7.6	7.5	8.0	9.7	10.6	12.4	15.5	16.1	
	Top Type	Direct	mm	192	207	203	271	326	339	359	402
			in	7.6	8.1	8.0	10.7	12.8	13.3	14.1	15.8
		Cap	mm	252	268	268	320	350	336	438	438
			in	9.9	10.6	10.6	12.6	13.8	13.2	17.2	17.2
		TS-P	mm	252	264	264	320	320	336	378	450
			in	9.9	10.4	10.4	12.6	12.6	13.2	14.9	17.7
	TR-F	mm	-	-	-	-	-	-	-	-	420
		in	-	-	-	-	-	-	-	-	16.5
Required Oil Flow		ℓ/min	15~30	20~40	25~50	30~60	40~70	50~90	60~100	80~110	
		gal/min	4~8	5.3~10.6	6.6~13.2	7.9~16	10.6~18.5	13.2~23.8	15.9~26.4	21.1~29.1	
Operating Pressure		kg/cm ²	90~120	90~120	90~120	100~130	110~140	120~150	130~160	150~170	
		psi	1280~1707	1280~1707	1280~1707	1422~1849	1565~1991	1707~2134	1849~2276	2134~2418	
Impact Rate		BPM	800~1400	700~1200	600~1100	500~1000	500~900	400~800	400~800	350~700	
Hose Diameter		in	$\frac{3}{8}$ " \bar{u} , $\frac{1}{2}$ " \bar{o}	$\frac{3}{8}$ " \bar{u} , $\frac{1}{2}$ " \bar{o}	$\frac{1}{2}$ " \bar{o}	$\frac{1}{2}$ " \bar{o}	$\frac{1}{2}$ " \bar{o}	$\frac{1}{2}$ " \bar{o}	$\frac{3}{4}$ " \bar{u}	$\frac{3}{4}$ " \bar{u}	
Rod Diameter		mm	40	45	53	60	68	75	85	100	
		in	1.6	1.8	2.1	2.4	2.7	3.0	3.3	3.9	
Applicable Carrier		m ³	~0.07	0.03~0.1	0.06~0.2	0.1~0.25	0.15~0.3	0.2~0.35	0.25~0.5	0.4~0.6	
		ton	0.8~2.5	1.2~3.0	2.5~4.5	3.0~5.5	4.0~7.0	6~9	7~14	11~16	
Noise Level		dB	105.5	106.8	108.5	116.9	108.7	114.5	112	113.5	

DESCRIPTION		UNIT	MODEL						
			SB60	SB70	SB81/ SB81A	SB100	SB121	SB130	
Body Weight	Including Rod	kg	618	759	910/940	1070	1283	1443	
		lb	1362	1673	2006/2070	2359	2829	3181	
Operating Weight	Side Type	kg	1255	1462	1740/1772	2144	2413	2650	
		lb	2767	3223	3836/3907	4727	5320	5842	
	Top Type	TR-F	kg	1330	1544	1830/1864	2065	2781	2996
			lb	2932	3404	4035/4109	4553	6131	6605
		TS-P	kg	1297	1500	1766/1798	2071	2632	2833
			lb	2859	3307	3893/3964	4566	5803	6246
Length	Side Type	mm	2195	2295	2429	2623	2776	2953	
		in	86.4	90.4	95.6	103.3	109.3	116.3	
	Top Type	TR-F	mm	2592	2682	2813	3063	3215	3392
		TS-P	in	102	105.6	110.7	120.6	126.6	133.5
Width	Side Type	mm	508	508	508	578	610	630	
		in	20	20	20	22.8	24	24.8	
	Top Type	TR-F	mm	550	550	620	620	720	720
		TS-P	in	21.7	21.7	24.4	24.4	28.3	28.3
Required Oil Flow		ℓ /min	90~120	100~150	120~180	150~210	180~240	200~260	
		gal/min	23.8 ~31.7	26.4 ~39.6	31.7 ~47.6	39.6 ~55.5	47.6 ~63.4	50.8 ~68.7	
Operating Pressure		kg/cm ²	150~170	160~180	160~180	160~180	160~180	160~180	
		psi	2134 ~2418	2276 ~2560	2276 ~2560	2276 ~2560	2276 ~2560	2276 ~2560	
Impact Rate		BPM	350~650	350~600	350~500	300~450	300~450	250~400	
Hose Diameter		in	1	1	1	1	1- $\frac{1}{4}$	1- $\frac{1}{4}$	
Rod Diameter		mm	125	135	140	150	155	165	
		in	4.9	5.3	5.5	5.9	6.1	6.5	
Applicable Carrier		m ³	0.5~0.7	0.6~0.8	0.7~0.9	0.9~1.2	1.1~1.4	1.2~1.7	
		ton	15~18	16~21	18~26	25~30	28~35	30~45	
Noise Level		dB	115	120	118	120	123	124	

* Operating weight including Cap and Rod weight by AEM regulation.

(Except for pin, hose, fitting, bush, stop ring and tubing)

* The above specifications are subject to change without prior notice for the quality enhancement.

* The above Noise level is TS-P type.

* Rod is long type standard.

DESCRIPTION		UNIT	MODEL						
			SB140	SB147	SB151	SB157	SB160	SB177	
Body Weight	Including Rod	kg	1579	1685	1924	2035	2050	2761	
		lb	3481	3715	4242	4486	4519	6087	
Operating Weight	Side Type	kg	2990	3101	3788	3897	3933		
		lb	6592	6836	8351	8591	8670		
	Top Type	TR-F	kg	3185	3314	3833	4108	4125	5273
		lb	7022	7306	8450	9057	9094	11625	
	TS-P	kg	3090	3309	3991	4085,5	–		
		lb	6812	7295	8799	9007	–		
Length	Side Type	mm	3031	3099	3176	3212	3211		
		in	119,3	122	125,0	126,4	126		
	Top Type	TR-F	mm	3475	3605,5	3736	3786	3786	4346
		TS-P	in	136,8	142	147,1	149	149	171
Width	Side Type	mm	630	630	665	665	665		
		in	24,8	25	26,2	26,2	26,2		
	Top Type	TR-F	mm	720	720	720	760	760	760
		TS-P	in	28,3	28,3	28,3	29,9	29,9	30
Required Oil Flow		ℓ /min	200~260	200~260	210~290	210~290	230~290	250~390	
		gal/min	50,8 ~68,7	52,8 ~68,7	55,5 ~76,6	55,5 ~76,6	56 ~76,6	66,0~103,0	
Operating Pressure		kg/cm ²	160~180	160~180	160~180	160~190	160~180	170~190	
		psi	2276 ~2560	2276 ~2560	2276 ~2560	2276 ~2702	2276 ~2560	2489 ~2702	
Impact Rate	–		250~350	–	200~350	–	–	150~250	
	H Mode	BPM	–	250~350	–	150~250	150~250		
	L Mode		–	300~450	–	300~340	200~300		
Hose Diameter		in	1- $\frac{1}{4}$ ù	1- $\frac{1}{4}$ ù	1- $\frac{1}{4}$ ù	1- $\frac{1}{4}$ ù	1- $\frac{1}{4}$ ù	1 $\frac{1}{4}$	
Rod Diameter		mm	165	165	175	175	180	190	
		in	6,5	6,5	6,9	6,9	7,1	7,5	
Applicable Carrier		m ³	1,2~1,7	1,0~1,7	1,4~2,0	1,4~2,0	1,4~2,0	1,5~3,5	
		ton	30~45	28~45	40~55	40~55	40~55	45~70	
Noise Level		dB	124	124	125	125	125	125	

- * Operating weight including Cap and Rod weight by AEM regulation.
(Except for pin, hose, fitting, bush, stop ring and tubing)
- * The above specifications are subject to change without prior notice for the quality enhancement.
- * The above Noise level is TS-P type.
- * Rod is long type standard.

DESCRIPTION		UNIT	MODEL
			SB43B
Body Weight	Including Rod	kg	236
		lb	520
Operating Weight	Side Silenced back hoe Type	kg	393
		lb	866
Length	Side Silenced back hoe Type	mm	1736
		in	68
Width	Side Silenced back hoe Type	mm	336
		in	13
Required Oil Flow		ℓ /min	50~90
		gal/min	13,2~23,8
Operating Pressure		kg/cm ²	150~170
		psi	2134~2418
Impact Rate		BPM	400~800
Hose Diameter		in	$\frac{3}{4}$
Rod Diameter		mm	75
		in	3,0
Applicable Carrier		m ³	0,2~0,35
		ton	6~9
Noise Level		dB	114,5
Nitrogen Charging Pressure of Accumulator		kg/cm ²	10
		psi	142
Nitrogen Charging Pressure of Back Head		kg/cm ²	16,5
		psi	235
Open Number of Adjuster Valve		–	2,5 Rotations
Volume of Accumulator		ℓ	0,25
		gal	0,07

- * Operating weight including Cap and Rod weight by AEM regulation.
(Except for pin, hose, fitting, bush, stop ring and tubing)
- * The above specifications are subject to change without prior notice for the quality enhancement.
- * The above Noise level is TS-P type.
- * Rod is long type standard.

03. External Dimension

3.1 Side Type

MODEL : SB10,20,30,35,40,43,45,50 SIDE

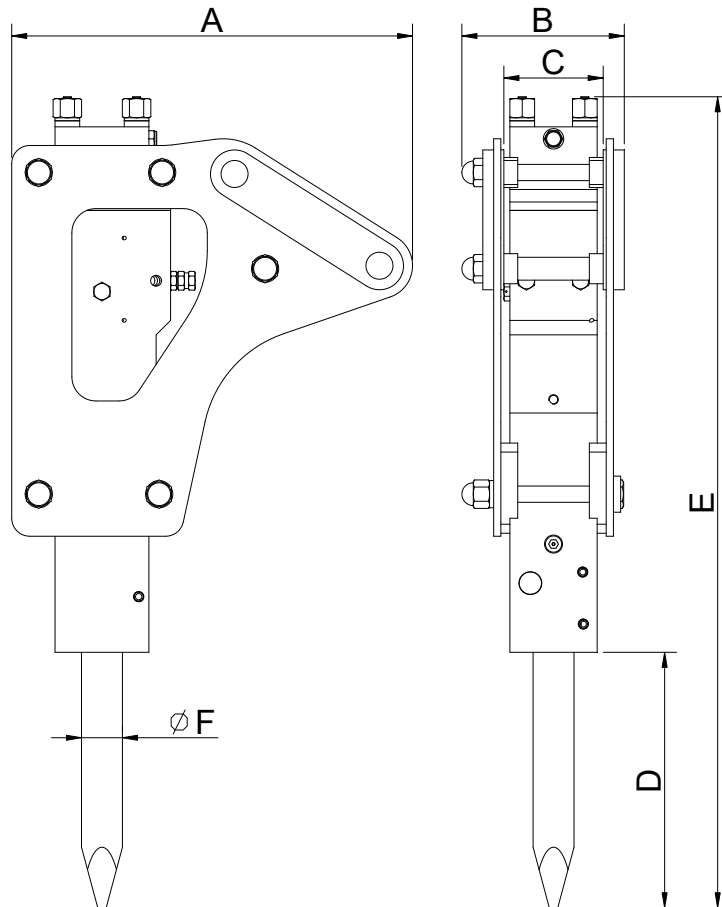

MODEL	A	B	C	D	E	F
SB10	363	192	130	297	972	40
SB20	424	191	140	326	1071	45
SB30	478	203	145	330	1147	53
SB35	547	247	165	374	1239	60
SB40	666	270	165	425	1349	68
SB43	752	315	220	507	1618	75
SB45	902	394	267	564	1827	85
SB50	914	408	275	561	1934	100

MODEL : SB60,70, 81(A),100,121,130,140,147P,147,151,157,160,152,177

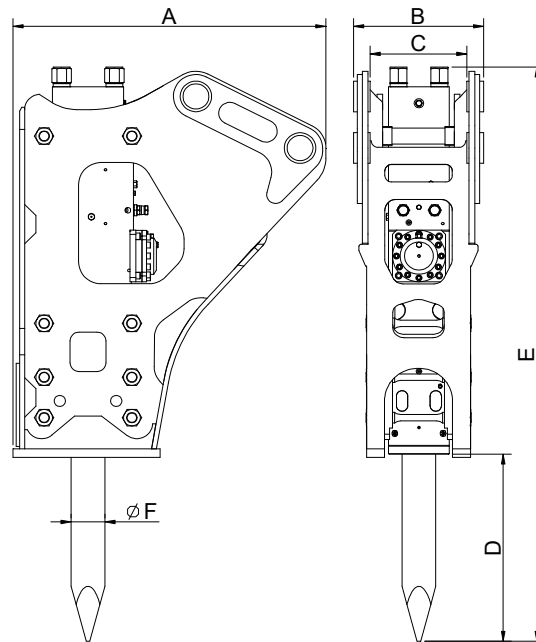

MODEL	A	B	C	D	E	F
SB60	1207	508	360	650	2195	125
SB70	1264	508	360	701	2295	135
SB81 SB81A	1135	508	360	762	2429	140
SB100	1392	578	430	854	2623	150
SB121	1436	610	450	913	2776	155
SB130	1489	630	470	952	2953	165
SB140	1521	630	470	952,5	3031	165
SB147	1487	630	470	902,5	3099	165
SB151	1670	665	495	918	3176	175
SB152	1661	665	495	868,5	3212	175
SB157	1615	665	495	893	3212	175
SB160	1615	665	495	868	3211	180

3.2 Backhoe Type

MODEL : SB40II BACKHOE

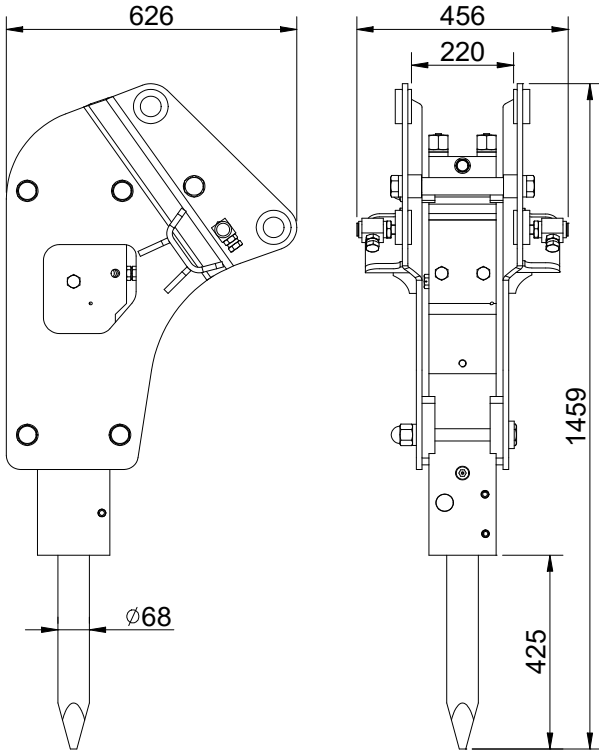

MODEL : SB40II BACKHOE(Heavy)

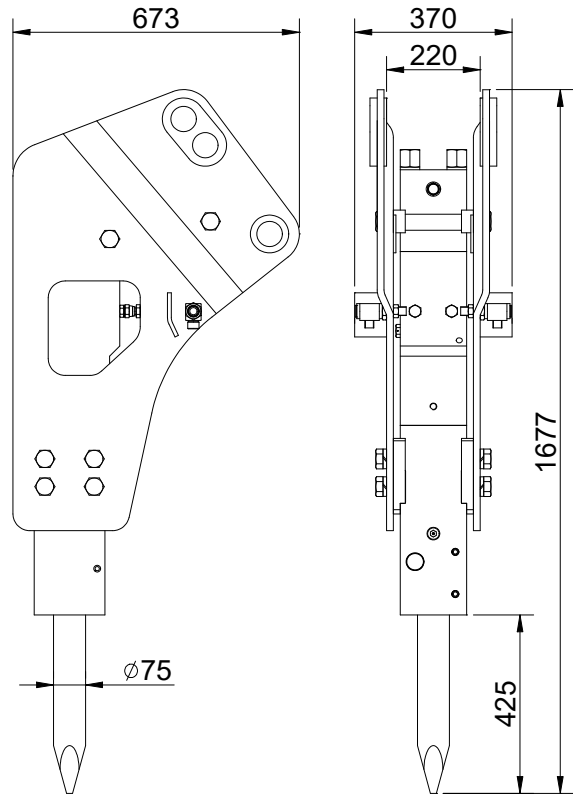

MODEL : SB43II BACKHOE

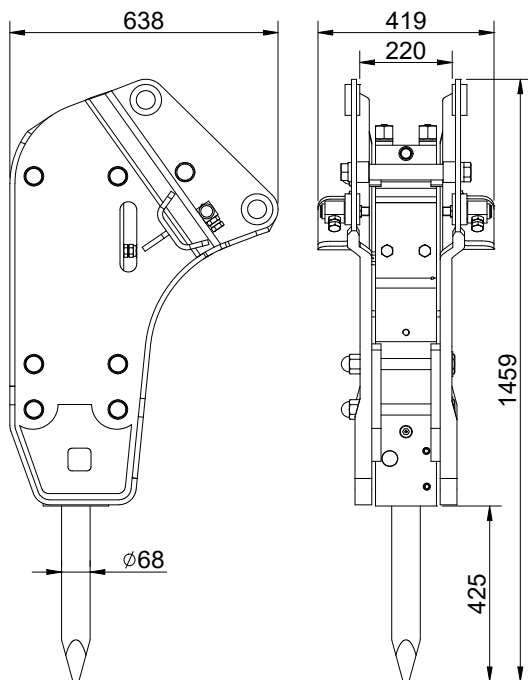

MODEL : SB45 BACKHOE

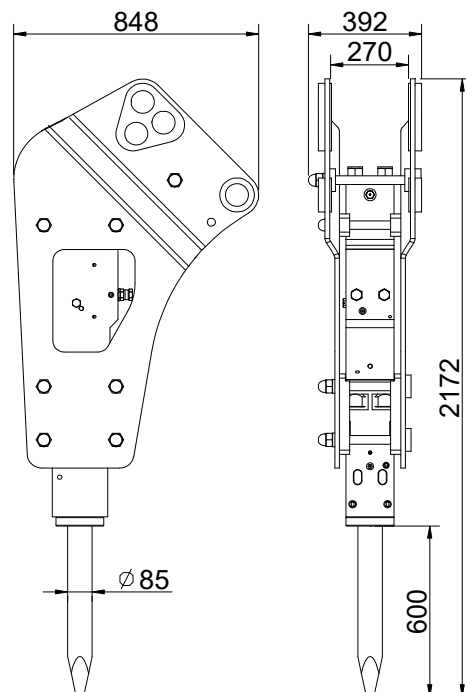

MODEL : SB40 SILENCED BACKHOE

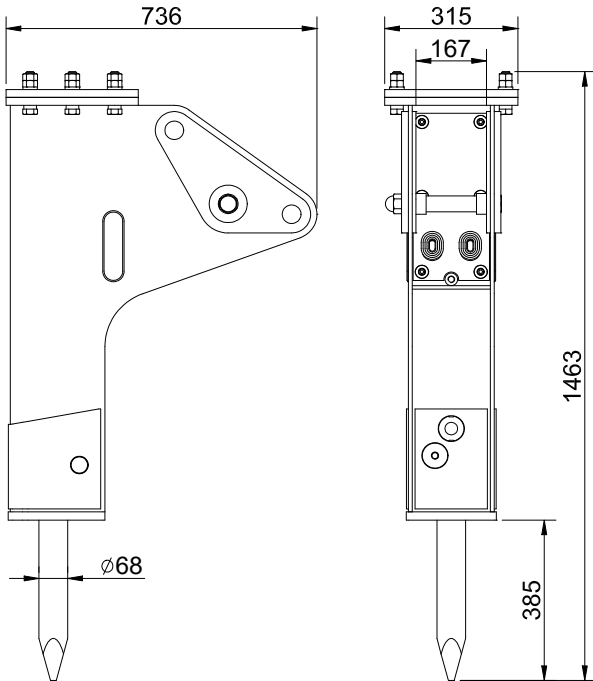

MODEL : SB43 SILENCED BACKHOE

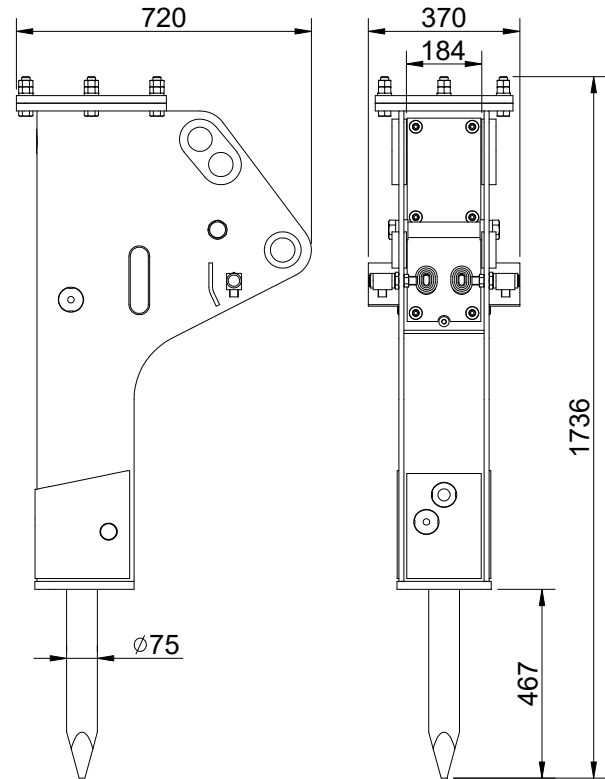

MODEL : SB43B SILENCED BACKHOE

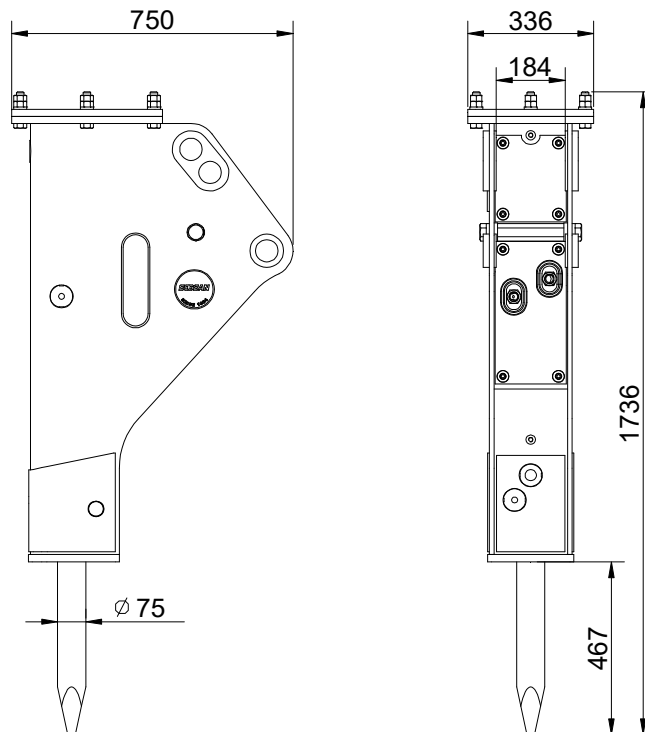

3.3 Top Type

3.3.1 Standard Top Type (Direct mounting)

MODEL : SB10II ~ 35II

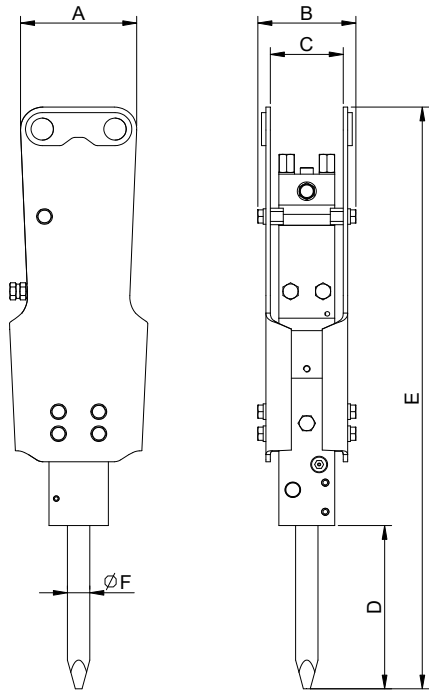

MODEL	A	B	C	D	E	F
SB10	208	176	130	297	1058	40
SB20	255	191	140	326	1163	45
SB30	279,5	203	145	330	1239	53
SB35	286	247	165	374	1333	60

MODEL : SB40~50

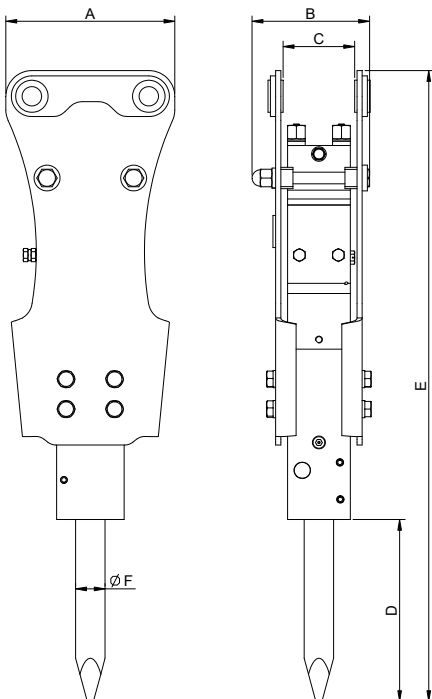

MODEL	A	B	C	D	E	F
SB40	390	271	165	425	1474	68
SB43	460	295	225	508	1767	75
SB45	530	359	269	564	2024	85
SB50	615	393	273	561	2150	100

3.3.2 Standard Top Type (Cap mounting)

MODEL : SB10II ~ 35II

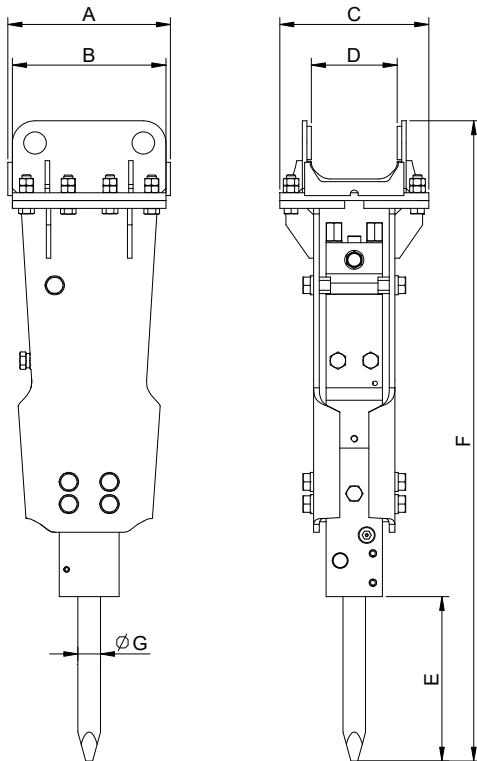

MODEL	A	B	C	D	E	F	G
SB10	288	272	264	152	297	1156	40
SB20	288	272	264	162	326	1255	45
SB30	288	272	264	162	330	1325	53
SB35	404	272	324	165	374	1474	60

MODEL : SB40 ~ 50

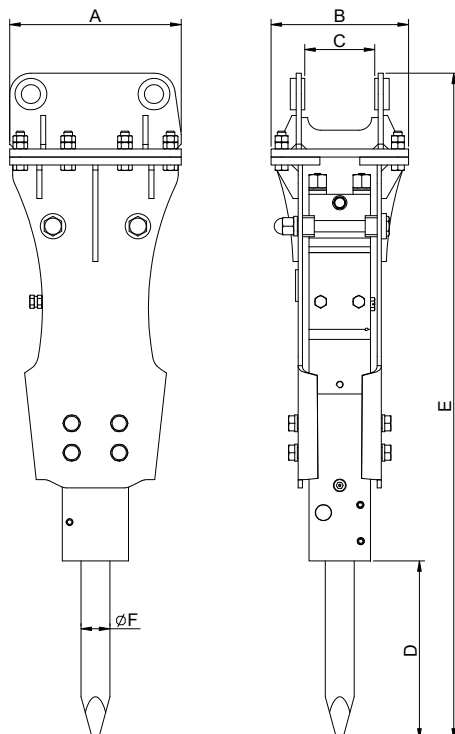

MODEL	A	B	C	D	E	F
SB40	404	324	165	425	1588	68
SB43	451	324	220	508	1187	75
SB45	570	420	267	564	2156	85
SB50	570	420	275	561	2300	100

3.3.3 TRENCH FINAL TYPE

MODEL : SB50,60,70,81,81A,100,121,130,140,157,151,160,177 TR-F

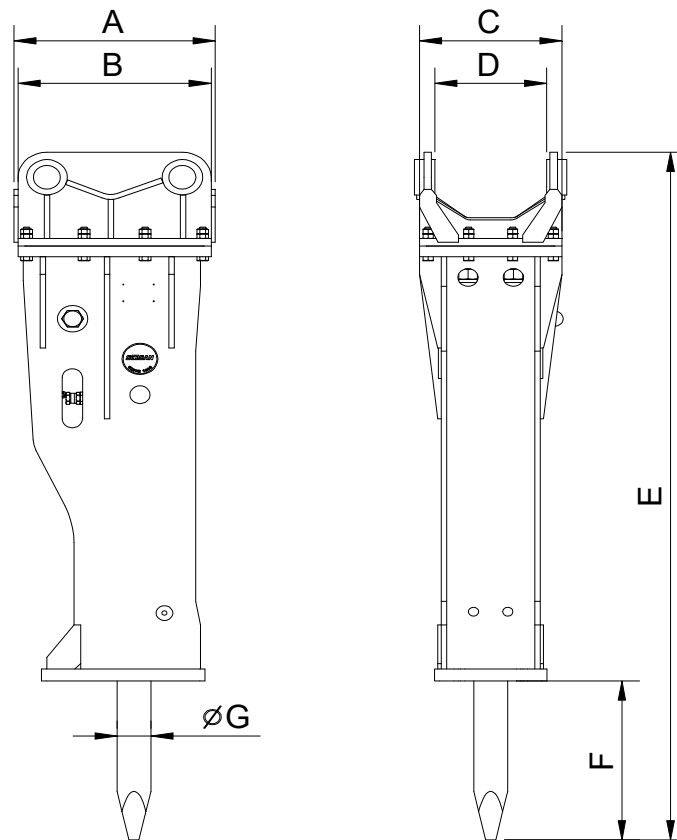

MODEL	A	B	C	D	E	F	G
SB50	594	570	450	330	2334	540	100
SB60	664	640	550	360	2592	609	125
SB70					2682	660	135
SB81 SB81A	784	760	620	360	2813	725	140
SB100					3063	807	150
SB121	880	856	720	450	3215	866	155
SB130					3392	906	165
SB140					3475	907	165
SB147					3606	907	165
SB151	898	856	720	495	3736	873	175
SB160	920	880	760	495	3786	873	180
SB177	896	1032	790	620	4236	942	190

3.3.4 TS-P Type

MODEL : SB10II,20II,30II, 35II,40II,43II TS-P

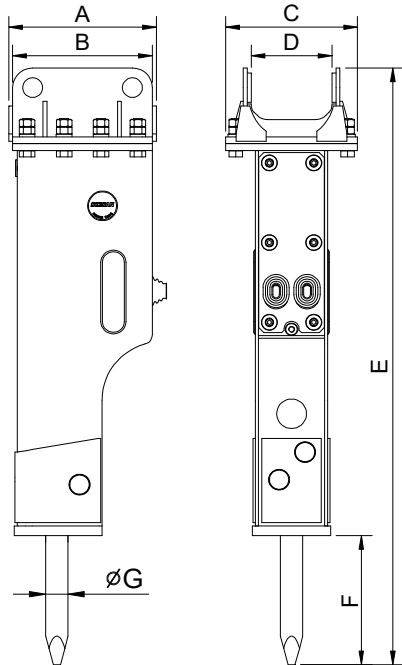

MODEL	A	B	C	D	E	F	G
SB10II	282	266	252	152	1135	267	40
SB20II	296	280	264	162	1213	262	45
SB30II	296	280	264	162	1317	295	53
SB35II	404	400	320	165	1472	339	60
SB40II	404	400	320	220	1620	385	68
SB43II	451	450	336	220	1899	467	75

MODEL : SB45,50 TS-P

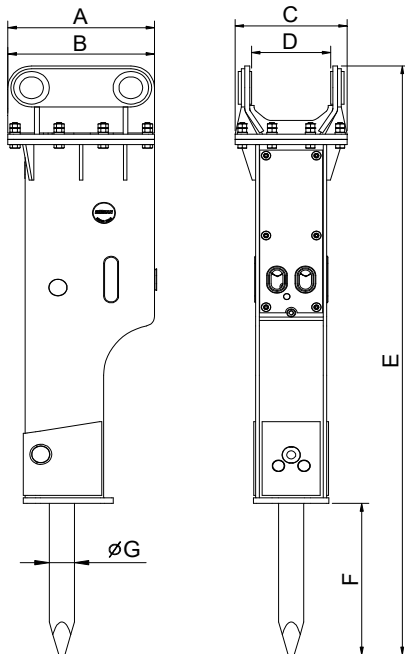

MODEL	A	B	C	D	E	F	G
SB45	570	495	378	267	2161	556	85
SB50	570	570	450	330	2316	531	100

MODEL : SB60,70,81,81A,100,121,130 TS-P

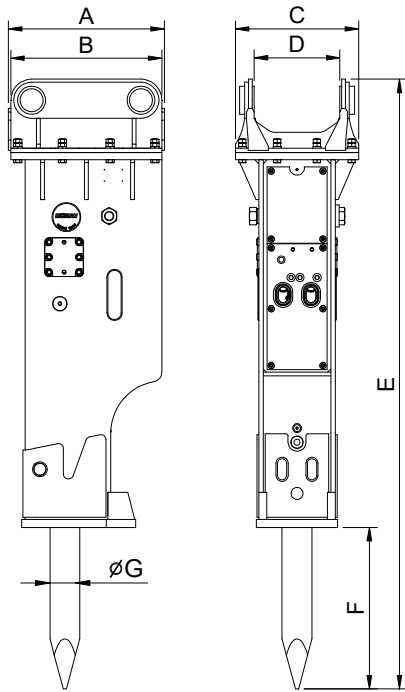

MODEL	A	B	C	D	E	F	G
SB60	664	640	550	360	2592	609	125
SB70					2682	660	135
SB81 SB81A	784	760	620	360	2813	725	140
SB100				430	3062	807	150
SB121	880	856	710	450	3215	866	155
SB130				450	3392	906	165

MODEL : SB140,147,151,157 TS-P

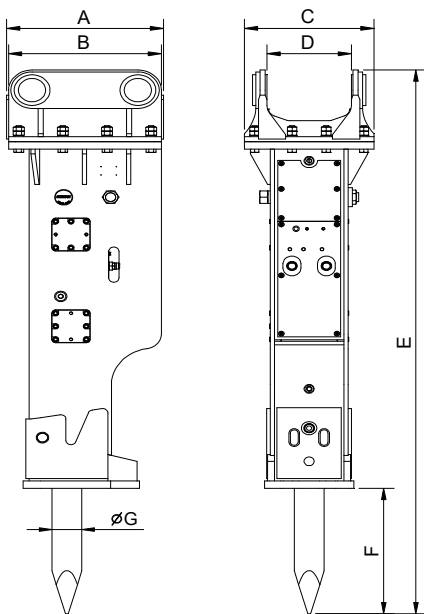

MODEL	A	B	C	D	E	F	G
SB140	880	856	720	450	3475	907	165
SB147					3545,5	906,5	165
SB151	898	856	720	495	3736	863	175
SB157					920	896	760

3.4 COVER PLATE(TS-P Type)

■ SB10II ~ 30II TS-P

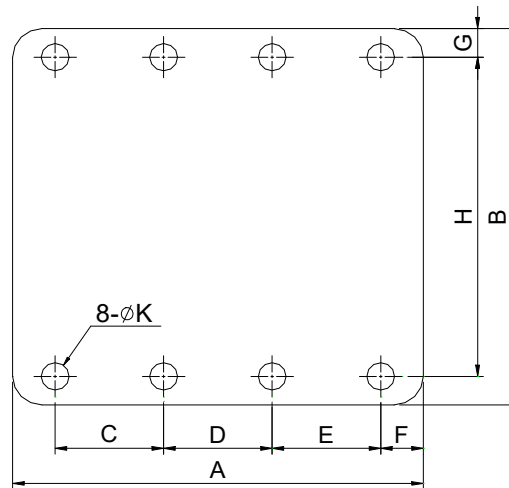

MODEL	A	B	C	D	E	F	G	H	K
SB10II TS-P									
SB20II TS-P	272	264	74	74	74	25	20	224	19
SB30II TS-P									

■ SB35II ~ 43II TS-P

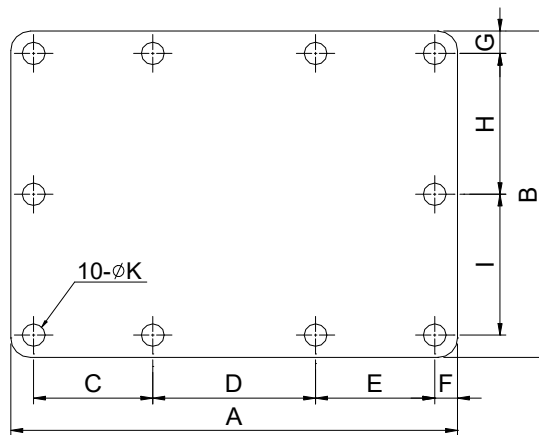

MODEL	A	B	C	D	E	F	G	H	I
SB35II TS-P									
SB40II TS-P	404	324	115	124	115	25	25	274	21
SB43II TS-P									

■ SB45~157 TS-P

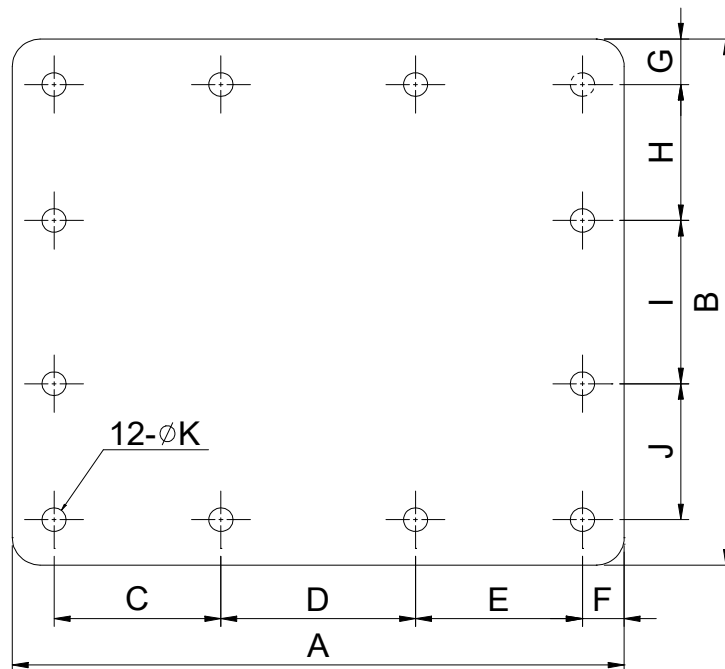

MODEL	A	B	C	D	E	F	G	H	I	J	K
SB45 TS-P	570	420	170	180	170	25	25	120	130	120	21
SB50 TS-P											
SB60 TS-P (#2398~)	640	550	180	210	180	35	35	150	180	150	26
SB70 TS-P (#4602~)											
SB81 TS-P (#8557~)	760	620	225	240	225	35	35	175	200	175	26
SB81A TS-P (#Not yet)											
SB100 TS-P (#2136~)											
SB121 TS-P (#5235~)	856	720	258	260	258	40	40	220	200	220	38
SB130 TS-P (#3363~)											
SB140 TS-P (#1481~)											
SB147 TS-P (#011~)											
SB151 TS-P (#1086~)											
SB157 TS-P (#011~)	896	760	278	260	278	40	40	240	200	240	38

■ SB50~160TR-F

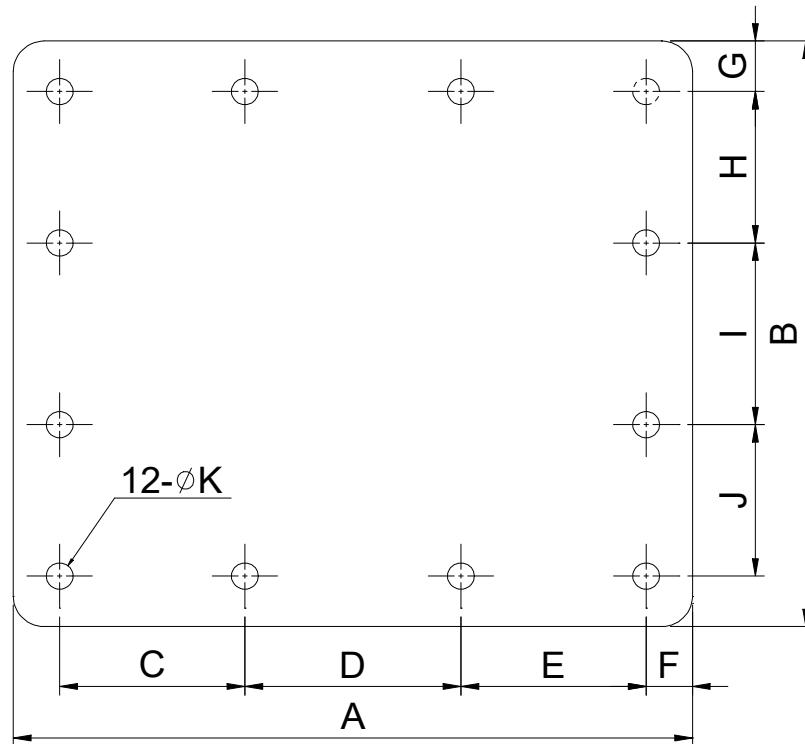

MODEL	A	B	C	D	E	F	G	H	I	J	K
SB50 TR-F (#11393~)	570	420	170	180	170	25	25	120	130	120	21
SB60 TR-F (#2478~)	640	498	180	190	180	45	35	150	180	150	26
SB70 TR-F (#5220~)											
SB81 TR-F (#10355~)	760	620	225	240	225	35	35	175	200	175	26
SB81A TR-F (#6037~)											
SB100 TR-F (#2225~)											
SB121 TR-F (#5714~)	856	720	258	260	258	40	40	220	220	220	38
SB130 TR-F (#3439~)											
SB140 TR-F (#1704~)											
SB147 TR-F (#011~)											
SB151 TR-F (#1132~)											
SB157 TR-F (#011~)	896	760	278	260	278	40	40	240	200	240	40
SB160 TR-F (#011~)											
SB177 TR-F											

04. Preparation for Installation and Operation.

4.1 Checking before installation instructions

CAUTION

CHECK THE "SPECIFICATIONS" SECTION OF THIS MANUAL TO DETERMINE CORRECT EXCAVATOR SIZES AND HYDRAULIC PRESSURE, HYDRAULIC FLOW IF HYDRAULIC PRESSURE, HYDRAULIC FLOW ARE EXCEEDED, THE HYDRAULIC BREAKER WARRANTY IS VOID

CAUTION

BE SURE THE FLUID IN THE HYDRAULIC SYSTEM IS CLEAN.
CHECK THE HYDRAULIC FILTER, REPLACE THE FILTER IF DIRTY OR DETERIORATED.
CHECK THE GAS PRESSURE ACCUMULATOR AND BACK HEAD.
SEE INSPECTION AND CHARGING OF NITROGEN GAS AT BACK HEAD, ACCUMULATOR HOSE AND PIPING FLEXING.

CAUTION

THE CONTAMINATED PART MUST BE CLEANED WITH NO DELAY.
HYDRAULIC OIL OR LIGHT OIL IS HIGHLY RECOMMENDABLE.

CAUTION

THE CIRCUIT RELIEF SETTING PRESSURE IS NOT FIXED.
BUT, IT WILL BE ADJUSTED BY PUMP CAPACITY.

■ Recommended circuit relief setting pressure and back pressure

MODEL	SB10II	SB20II	SB30II	SB35II	SB40II	SB43II	SB43B	SB45	SB50
Relief Setting Pressure[kg/cm ²]	150	150	160	160	170	180	190	190	200
Back Pressure [kg/cm ²]	10	10	10	10	10	10	10	10	10

MODEL	SB60	SB70	SB81 SB81A	SB100 SB121 SB130	SB140 SB147 SB147P	SB151 SB157 SB160	SB152 SB161	SB177
Relief Setting Pressure[kg/cm ²]	200	210	210	210	210	210	230	230
Back Pressure [kg/cm ²]	10	10	10	10	10	10	10	10

4.2 Installation and Removal

■ Side Bracket Type

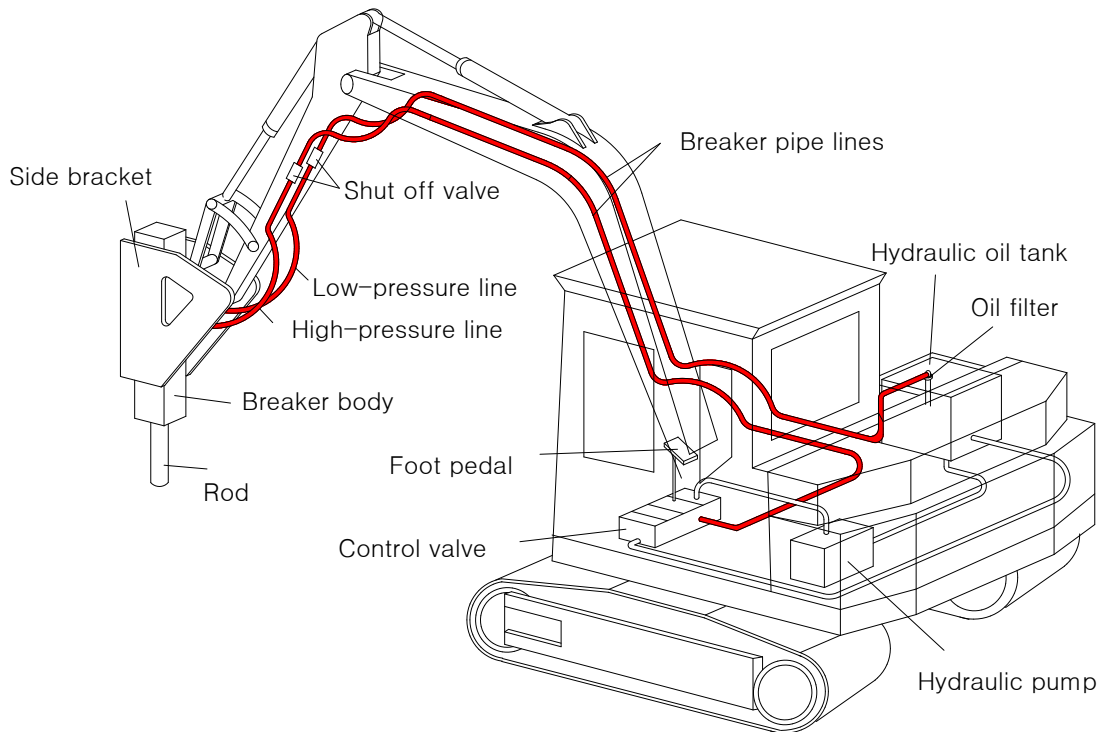

■ Top Bracket Type & Trench Type.

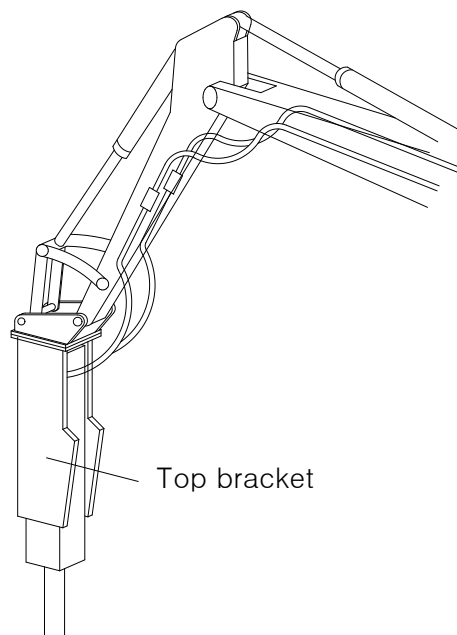

■ Removal of the Hydraulic Breaker

When the bucket and breaker operation alternately, the bucket and breaker can be easily exchanged by the hydraulic hoses and two mounting pins. However there is a risk of hydraulic contamination accordingly, do installation and removal as follows.

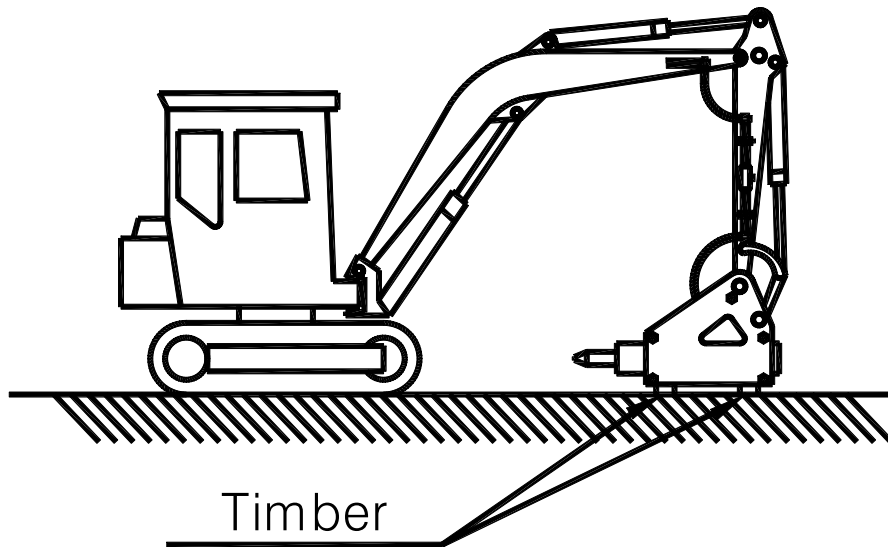

- (1) Move the carrier to stable ground free from mud, dust and dirt.
- (2) Place the hydraulic breaker on timber.
- (3) Stop the engine, turn off the main switch and deflate air from oil tank if it is
- (4) Turn 90° the shut off valve installed to the end of arm to prevent hydraulic from flowing out.

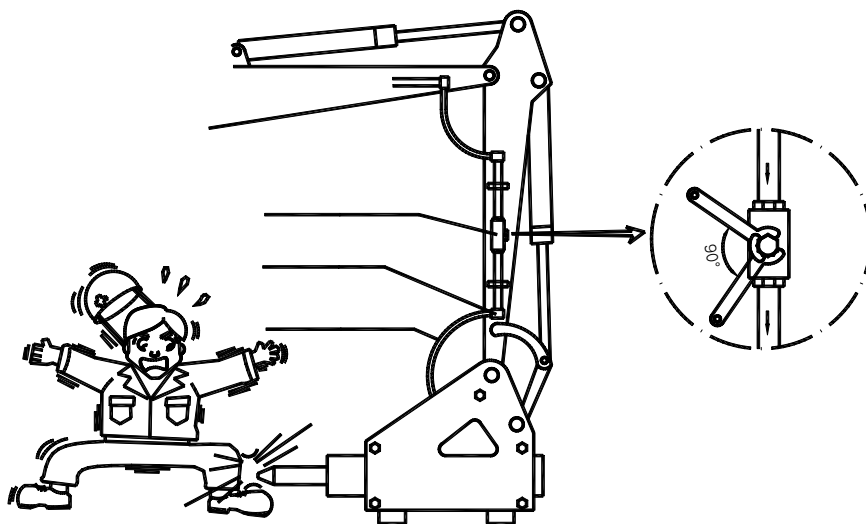

- (5) Loosen hose plug on the breaker arm. Collect small amount of oil flowing out at this time and put into a container.
- (6) Be careful to prevent mud or dust from entering oil hoses and pipe lines. Plug oil hoses with hose plug and pipe lines with union caps. Bind high-and low-pressure hoses with a wire to prevent them from getting mud.

■ Oil hose plug

The oil hose plug is used to plug the hose attached to the hydraulic breaker. It prevents mud or dust from entering the hose when the hydraulic breaker is removed from the carrier for bucket operation.

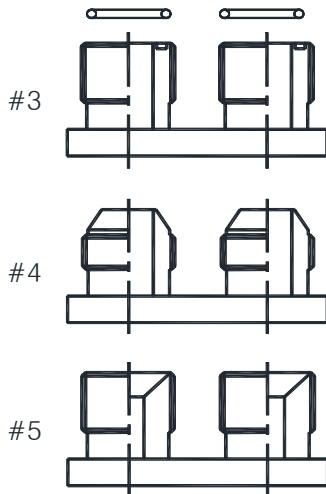

MODEL	TYPE	P/ N	TYPE	P/ N	TYPE	P/ N	O-RING (#3)
SB10II	-	-	# 4	2715302	# 5	2715306	-
SB20II	-	-	# 4	2715302	# 5	2715306	-
SB30II	-	-	# 4	2715302	# 5	2715306	-
SB35II	-	-	# 4	2715302	# 5	2715306	-
SB40II	-	-	# 4	2715302	# 5	2715306	-
SB43II	-	-	# 4	2715302	# 5	2715306	-
SB45	-	-	# 4	2715303	# 5	2715307	-
SB50, 57	-	-	# 4	2715303	# 5	2715307	-
SB60	# 3	2715300	# 4	2715304	# 5	2715308	2856004
SB70	# 3	2715300	# 4	2715304	# 5	2715308	2856004
SB81(A), 87	# 3	2715300	# 4	2715304	# 5	2715308	2856004
SB100	# 3	2715300	# 4	2715304	# 5	2715308	2856004
SB121	# 3	2715301	# 4	2715305	# 5	2715309	2856005
SB130, SB135	# 3	2715301	# 4	2715305	# 5	2715309	2856005
SB147	# 3	2715301	# 4	2715305	# 5	2715309	2856005
SB151,157, 160	# 3	2715301	# 4	2715305	# 5	2715309	2856005
SB177	# 3	2715301	# 4	2715305	# 5	2715309	2856005

■ Union cap

The union cap is used to cap the piping bracket attached to the carrier for prevention of the piping bracket from being smeared with mud during bucket operation.

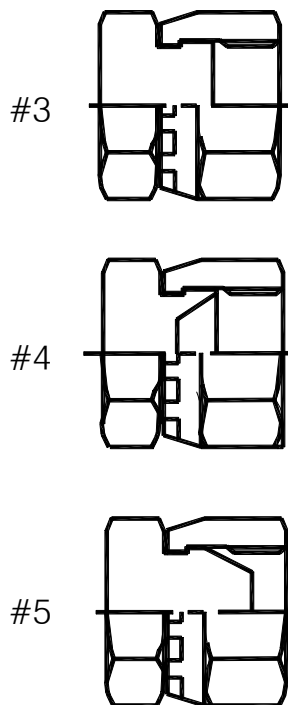

MODEL	TYPE	P/ N	TYPE	P/ N	TYPE	P/ N
SB10II	# 3	-	# 4	C01202	# 5	2715002
SB20II	# 3	-	# 4	C01202	# 5	2715002
SB30II	# 3	-	# 4	C01202	# 5	2715002
SB35II	# 3	-	# 4	C01202	# 5	2715002
SB40II	# 3	-	# 4	C01202	# 5	2715002
SB43II	# 3	-	# 4	C01202	# 5	2715002
SB45	# 3	-	# 4	C11149	# 5	2715003
SB50, 57	# 3	-	# 4	C11149	# 5	2715003
SB60	# 3	2715063	# 4	C21132	# 5	2715004
SB70	# 3	2715063	# 4	C21132	# 5	2715004
SB81(A), 87	# 3	2715063	# 4	C21132	# 5	2715004
SB100	# 3	2715063	# 4	C21132	# 5	2715004
SB121	# 3	2715064	# 4	C31175	# 5	2715005
SB130, 135	# 3	2715064	# 4	C31175	# 5	2715005
SB147	# 3	2715064	# 4	C31175	# 5	2715005
SB151,157,160	# 3	2715064	# 4	C31175	# 5	2715005
SB177	# 3	2715064	# 4	C31175	# 3	2715005

■ ADAPTER

This parts connect to BREAKER IN/OUT port with hydraulic hose.

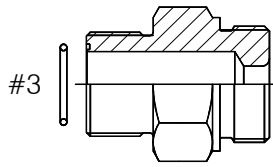

#3

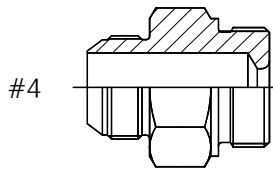

#4

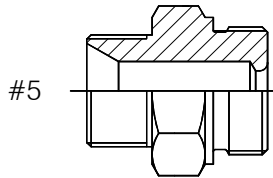

#5

MODEL	TYPE	P / N	TYPE	P / N	TYPE	P / N	O-RING (#3)
SB10II	# 3	-	# 4	C01201	# 5	C91120	-
SB20II	# 3	-	# 4	C01201	# 5	C91120	-
SB30II	# 3	-	# 4	C01201	# 5	C91120	-
SB35II	# 3	-	# 4	C01201	# 5	C91120	-
SB40II	# 3	-	# 4	C01201	# 5	C91120	-
SB43II	# 3	-	# 4	C01201	# 5	C91120	-
SB45	# 3	-	# 4	C01121	# 5	2710311	-
SB50, 57	# 3	-	# 4	C01121	# 5	2710311	-
SB60	# 3	C21124	# 4	C21131	# 5	2710315	2856004
SB70	# 3	C21124	# 4	C21131	# 5	2710315	2856004
SB81(A), 87	# 3	C31115	# 4	C31201	# 5	C31193	2856004
SB100	# 3	C31115	# 4	C31201	# 5	C31193	2856004
SB121	# 3	C61150	# 4	C61152	# 5	2710319	2856005
SB130, SB135	# 3	C61150	# 4	C61152	# 5	2710319	2856005
SB140P,147P,147	# 3	C61150	# 4	C61152	# 5	2710319	2856005
SB151,157, 160	# 3	C61150	# 4	C61152	# 5	2710319	2856005
SB177	# 3	C61150	# 4	C61152	# 5	2710319	2856005

* O-Ring(#3) use only TYPE #3.

4.3 Hydraulic pipe lines for exclusive use

Operation of the hydraulic breaker requires installation of hydraulic pipe lines for exclusive use of the hydraulic breaker. As hydraulic pipe lines vary depending on base machines, our service engineer must first check hydraulic pressure, oil capacity, pressure loss and other conditions of the base machine before installing hydraulic pipe lines. Use only genuine parts in case of replacement because hydraulic pipe lines(hoses, pipes and fittings) are made of materials carefully selected in consideration of durability.

WARNING

THE HYDRAULIC SYSTEM TO THE BASE MACHINE MUST BE CHECKED BY AN AUTHORIZED SOOSAN SERVICE ENGINEER BEFORE FIRST USE AND AFTER ANY MODIFICATIONS.

WARNING

MAKE SURE THAT THE HYDRAULIC BREAKER VALVE OF HYDRAULIC SYSTEM IS PROPERLY SET.

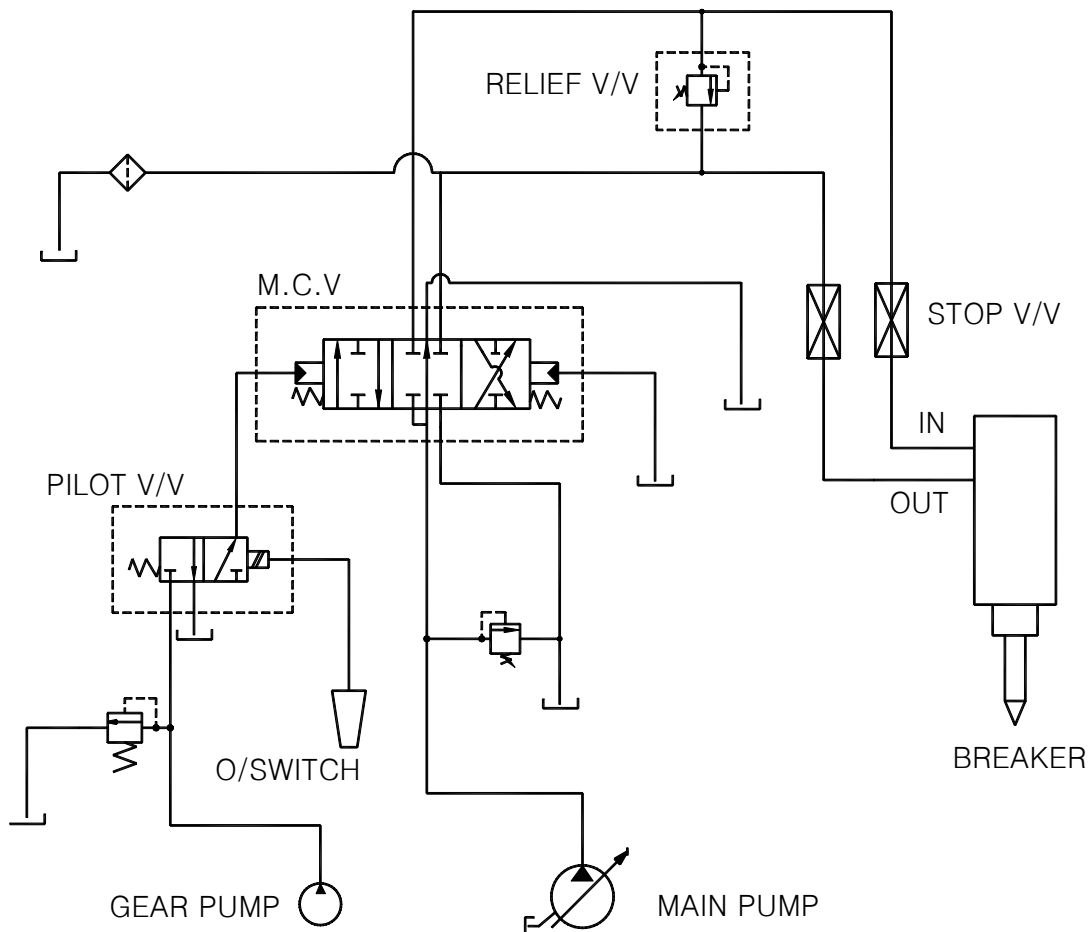

05. Precautions for safe operation.

[1] Proper position must be applied for an effective usage of breaking force.

When position is incorrect, hammering energy of the piston is too weak to break rocks, Instead, hammering force applies shocks to the breaker body, breaker arm and boom of the base machine, thereby resulting in damage to those parts.

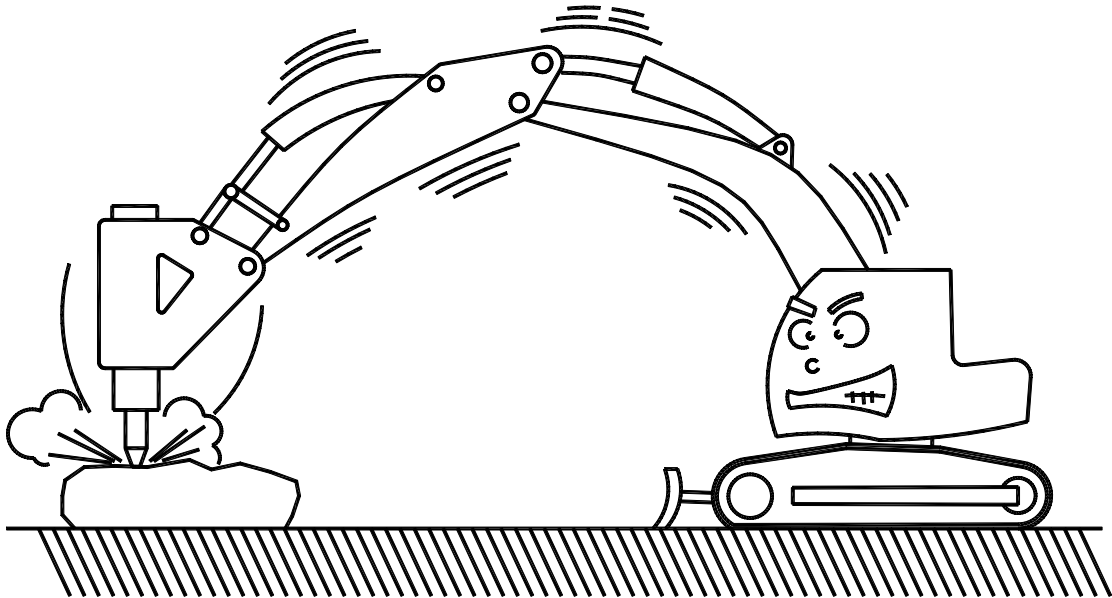

[2] On the contrary, when position is excessive enough to break rocks with front of the base machine raised, the machine may suddenly tilt forward the moment rocks are broken. Then, the breaker body or the end of bracket may violently hit against rocks and result in damage.

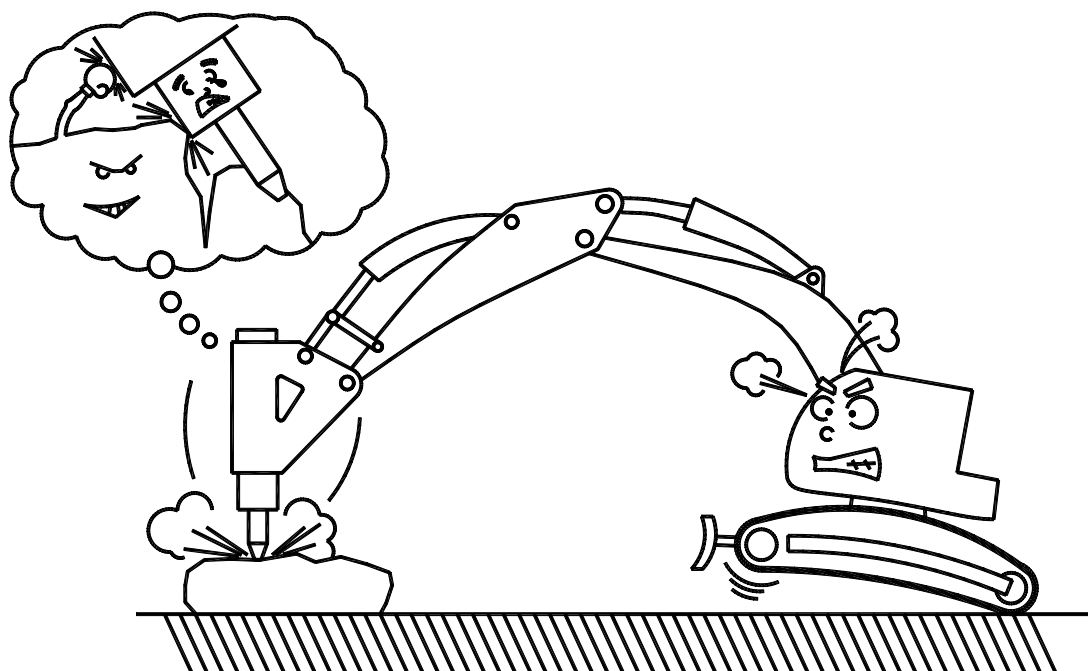

[3] It is undesirable to carry out hammering under the below condition, because vibrations during hammering may be transmitted to tracks of the base machine.

During hammering, however, proper position must be always applied to the breaker. Special care must be taken not to hammer under abnormal condition.

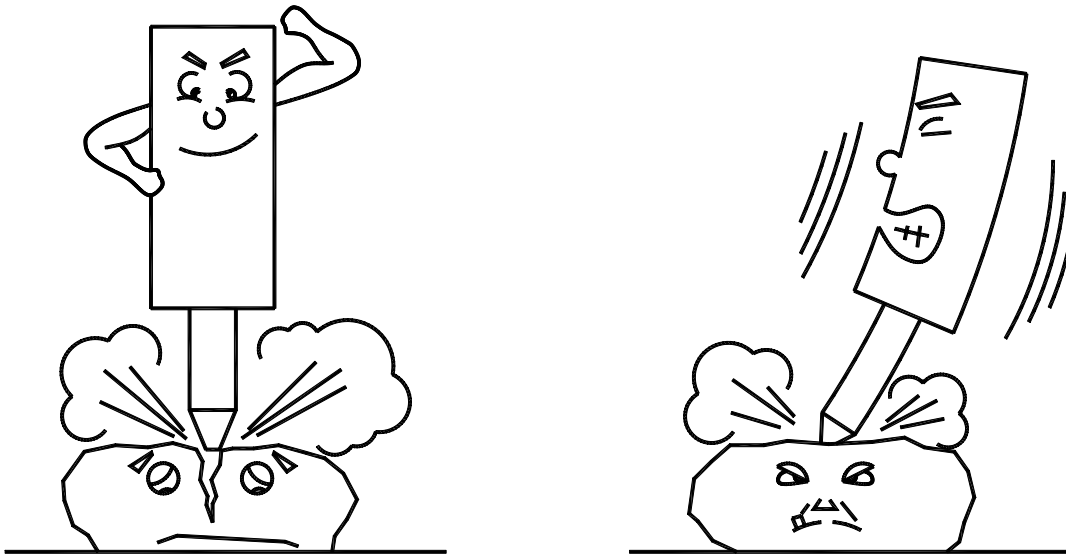

[4] Apply same direction of boom force in line with the rod and place the rod in the rock with hammering surface as vertical as possible. If hammering surface is oblique, the rod may slip during hammering. This causes the rod to seize and to be broken and piston to be damaged. When breaking, fully stabilize the rod first and then select the point of a rock on which hammering can be performed in a stable condition.

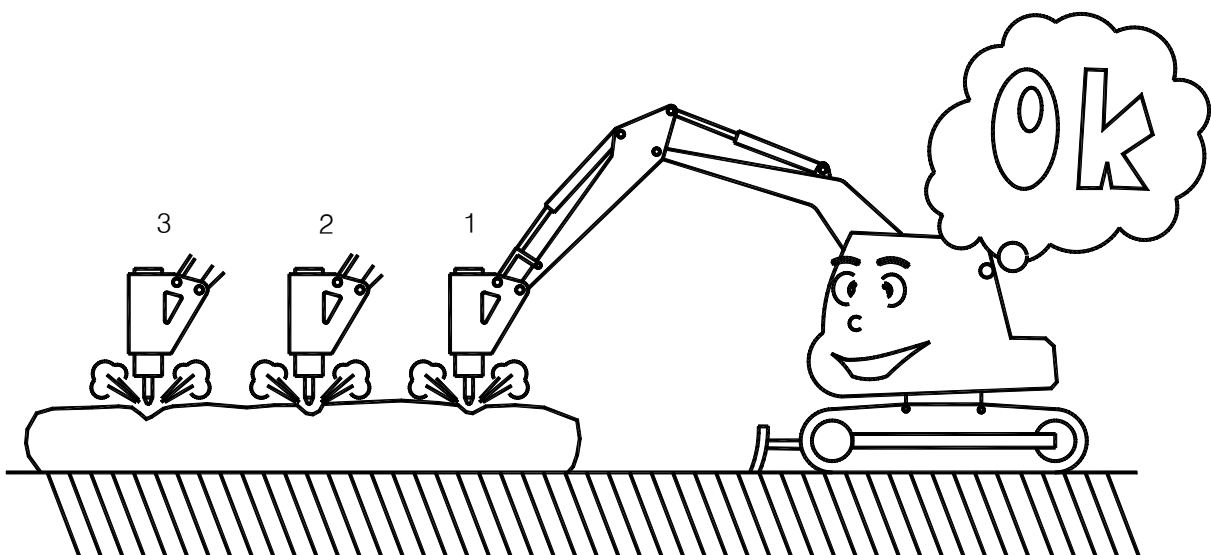

- [5] Rolling or falling a rock with the rod end or bracket side by using the boom or arm of the carrier as shown in the figure will result in breakage of the breaker mounting bolt or bracket, breakage and galling of rod, and damage to the arm and boom. Do not move rock. It is strictly prohibited to travel when the breaker is in the contact with rock.

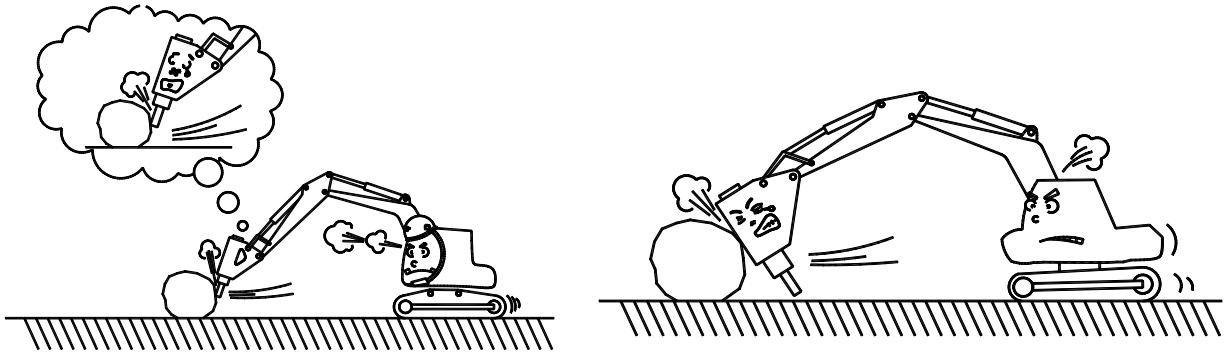

- [6] Do not use rod as a lever. Do not put the rod into a crack in rock and move the rod to and fro to breaker the rock, otherwise the rod will be broken or the bracket will be damaged.

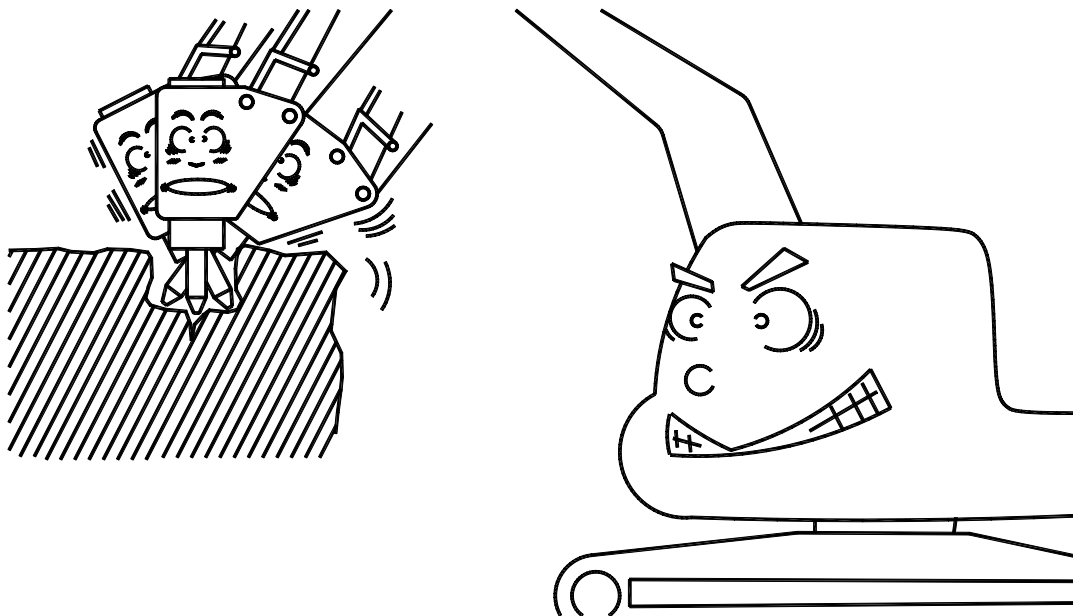

- [7] Do not operate breaker when all components except rod are immersed in water and mud. Underwater usage of the breaker will cause internal damage to the breaker. Consult Soosan for modifications if you have an underwater requirement.

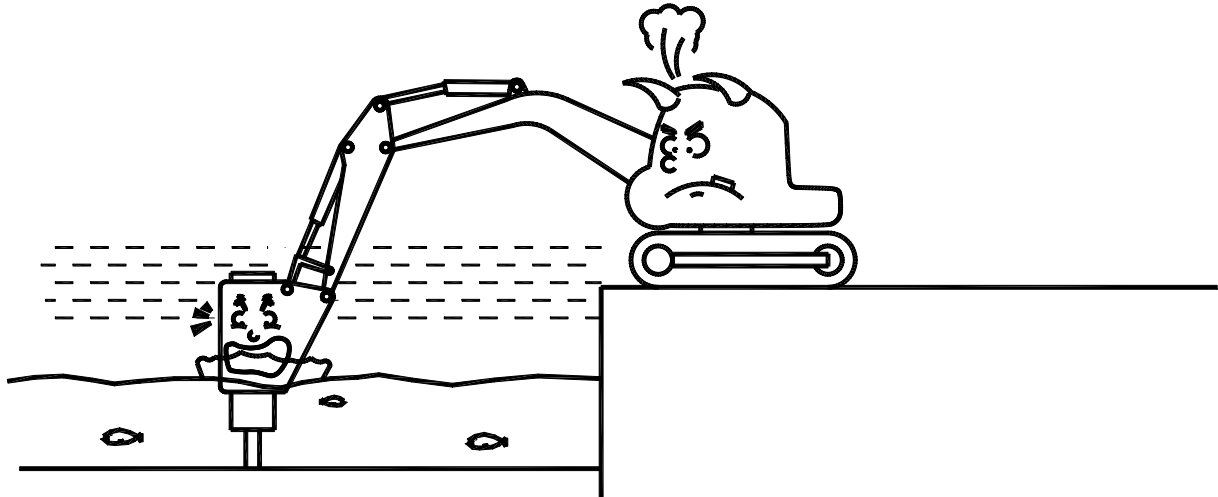

- [8] Do not allow the breaker to fall to a rock. Falling down the breaker will apply excessive force to the breaker or the carrier, causing damage to the parts of the breaker and carrier.

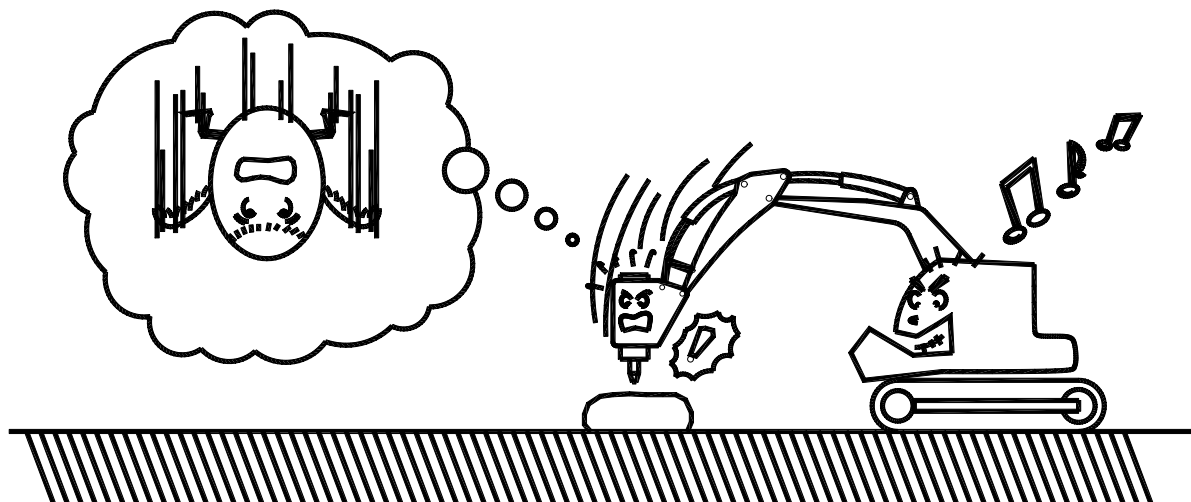

- [9] Breaking operation conducted at the stroke end (when the cylinder is extended or retracted to a maximum extent) of respective hydraulic cylinders of the carrier will lead to damage to the cylinders and other parts of the carrier.

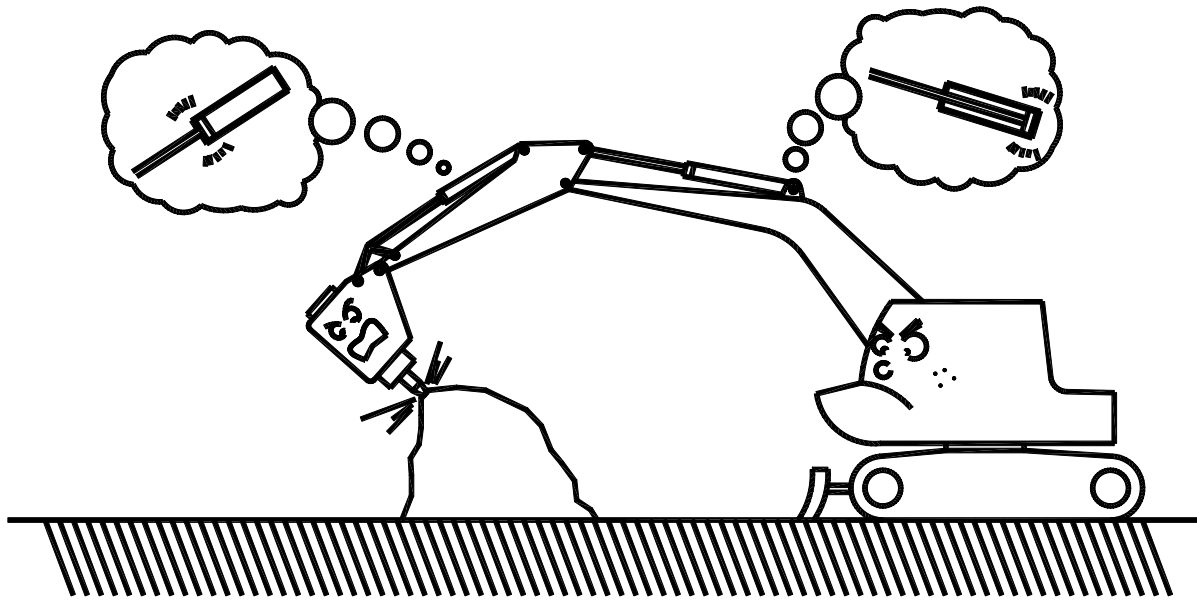

- [10] Lifting thing by hanging wire in the bracket or rod not only causes damage to the breaker but also is very dangerous.

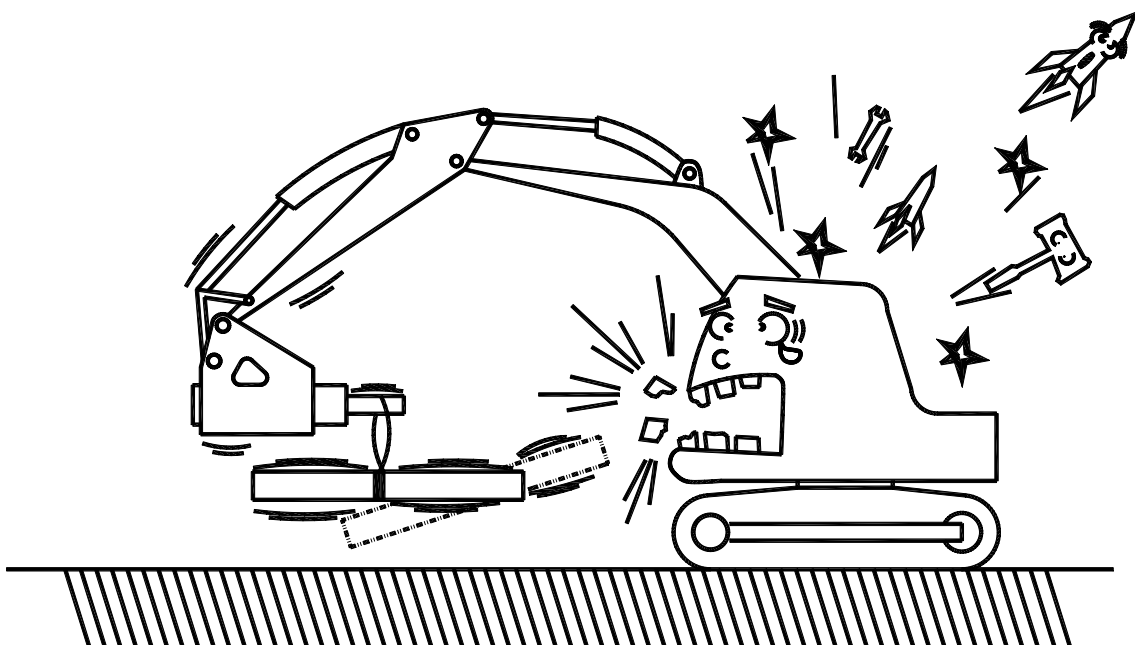

[11] Warm-up of machine prior to operation

- Do not operate the machine right after starting the engine. Idle the machine for warm-up. Warm the hydraulic oil sufficiently especially in winter or in the cold place.
- Especially in winter, the carrier's engine should be warmed up for 5 to 10 minutes 30~40°C(86~105°F) before breaker operation.
- When operating the hydraulic breaker, idle the engine and operate the hydraulic breaker with a light load.

[12] Stop operation when hoses are vibrating abnormally.

Check the hoses on the high pressure and low pressure sides of the breaker for abnormal vibration. If they are vibrating abnormally, contact the nearest Soosan dealer.

[13] Avoid blank hammering.

Blank hammering accelerates wear and tear on breaker and carrier components and may result in failure of one or more components. Excessive blank hammering may be considered equipment abuse and may result in voiding warranties. In case of blank hammering, hammering sound changes.

[14] Operate the breaker at proper engine speed.

Break rocks at the specified engine speed. Raising engine speed more than necessary does not strengthen hammering force but increase oil temperature to the detriment of piston and valve.

[15] ABS&IPC (SB147, 157, 160)

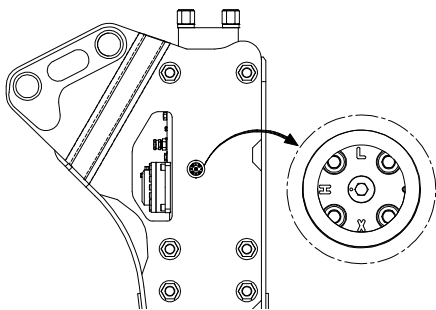

STEP1. Check the Selected Mode

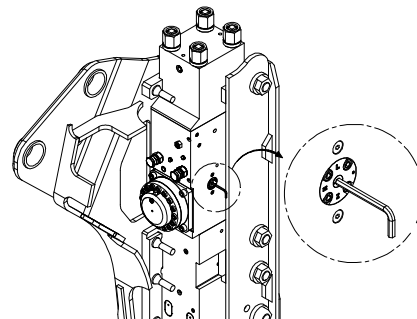

STEP2. Change the Mode

with 8mm L-Wrench

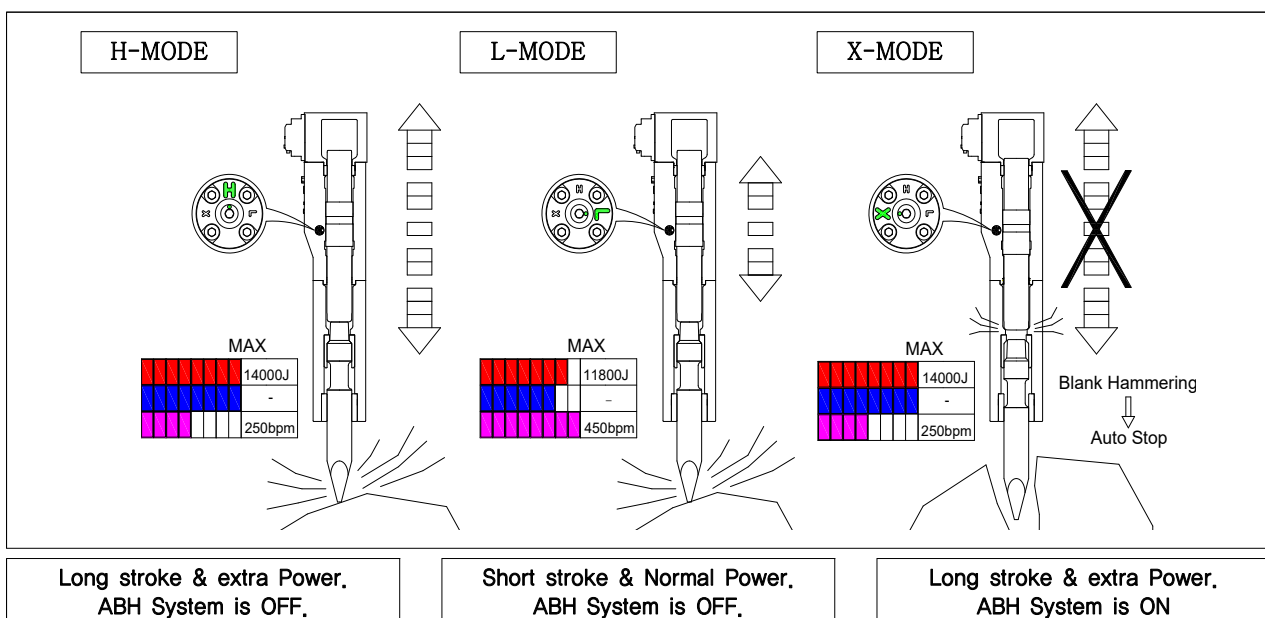

※ Select "X"MODE during Secondary breaking small stones works.

06. Maintenance

■ Regular Hydraulic breaker Inspection and Maintenance



Regular inspection is essential for keeping hydraulic breaker operating in the best condition consult with the Soosan service station for regular inspection and maintenance. Customers are recommended to contact the service station for inspection within six months after delivery.

■ Maintenance of Hydraulic breaker

Check cycle	Check Item	Location
Ordinary check items before and after operating breaker	<ul style="list-style-type: none"> ● Confirm the state of setting breaker and carrier <ul style="list-style-type: none"> * Damage and assembled state of bracket pin * Fastened state of pin assembled bolts * State of quick-clamp setting and bolts/pins assembled * State of cap mounting bolt(TOP Type) 	
	<ul style="list-style-type: none"> ● Assembling state of breaker and bracket <ul style="list-style-type: none"> * State of side-bolt and all kinds of bolt * Whether all kinds fixing part and anti-shock parts (cushion & wear plate)are damaged * State of bracket-crack, breakage, welded area 	E
	<ul style="list-style-type: none"> ● Fastening state of breaker main-body parts <ul style="list-style-type: none"> - Fastening and breakage state of pins, blocks, bolts * Fastened through bolt state * Front head pin and Rubber plugs * Stop pin and Rubber plugs * Air check valve * Back head charging valve * Valve adjuster * Accumulator mounting bolt * Accumulator cover fastening bolt * Accumulator charging valve * Hose adapter * Hex Head Plug 	A G F H B C D I J
	<ul style="list-style-type: none"> ● Damage of safety/warning sticker 	
	<ul style="list-style-type: none"> ● Loss or fastening state of bracket assembled parts <ul style="list-style-type: none"> * Sound plug(Silenced type) * Window cover(Silenced type) * Hose cover(Silenced type) 	
	<ul style="list-style-type: none"> ● Leakage, interference and assembling state of carrier hoses and pipes <ul style="list-style-type: none"> * Interference and assembling state of hoses and pipes * Fixing state of control valve * Welding state of clamps * Leakage and fastening state of pipes/hoses connected * Whether hose are twisted/damaged/aged 	
	<ul style="list-style-type: none"> ● Oil tank and working fluid quality <ul style="list-style-type: none"> * Quantity of working fluid * Contamination of working fluid 	
	<ul style="list-style-type: none"> ● Breaker on/off switch and electric wire 	
	<ul style="list-style-type: none"> ● Examine worsen state of consumable parts <ul style="list-style-type: none"> * Inside diameter of front cover * Worsen state of rod 	

Check cycle	Check Item	Location
Any time check items during operating breaker	● Temperature of working fluid(below 80°C/176°F)	
	● Loss and damage of parts	
	● Leakage of breaker hoses – A little leakage could be run on the rod (as much as it does not affect operating, performance and efficiency)	
	● Efficiency and abnormal working of breaker * Irregular blowing is occurred * Abnormal blowing sound is occurred * Pipes and hoses are shaken extremely	
After 1Hr operating	● Grease pumping(about 20cc after 1hr operating) – About 5~10 times pumping with grease gun * Rod friction area : Ring bush, Front cover, Rod pin	
Every week (Every 50hr operating)	● Quantity and contamination degree of working fluid(Refill or replace) * Contamination limit : 20~40cst	
	● Examining wear of consumable parts (Grind the area deformed if necessary) * Rod pin * Ring bush * Front cover	
	● Remove strange material inside of front head	
	● Check the gas pressure and refill * Back head * Accumulator	
Every month (Every 200 Hr operating)	● Whether all kinds of bolts are fastened by regulated torque	
	● Operating pressure of breaker	
	● Relief setting pressure of hydraulic circuit	
	● Supply flow	
Every 3month (Every 500 ~ 1000operating)	● Replace oil filter of carrier	
	● Replace seal kit	
	● Replace diaphragm of accumulator	
	● Examine if piston is pressed or deformed	
Hold breaker over 1month	● Examine if hydraulic parts are scratched if necessary grind and repair them	
	● Sufficient greasing * Rod, Rod pin, Front cover, Ring bush	
	● Lubricate piston surface	
	● Remove N ₂ Gas * Back head * Accumulator	
After under water operating	● Paint area fallen off	
	● Clean and grease after disassemble all parts of main body	

* The maintenance related with carrier follows carrier manufacturer rule

■ Daily Inspection before operating

Be fore starting operation, be sure to inspect the breaker referring to the following table.

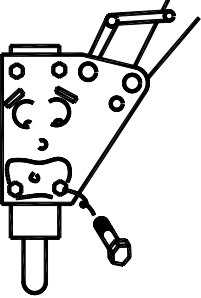
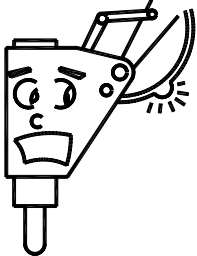
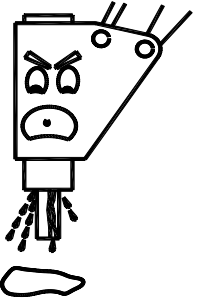
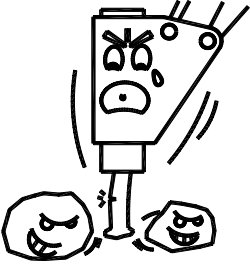
Inspection Item	Inspection Point	Remedy
<ul style="list-style-type: none"> - Looseness, missing and damage to bolts and nuts 	<ul style="list-style-type: none"> - Through bolt - Bracket mounting bolt 	<ul style="list-style-type: none"> - Check looseness. - Retighten to correct Tightening torque.
<ul style="list-style-type: none"> - Looseness of hose fittings, visible damage to hoses & oil leakage 	<ul style="list-style-type: none"> - Hydraulic piping for breaker - Oil hose 	<ul style="list-style-type: none"> - Retighten sufficiently. - Replace when damaged.
<ul style="list-style-type: none"> - Abnormal oil leakage 	<ul style="list-style-type: none"> - Connection of back head and cylinder - Gap between front head and rod * But small leakage is normal. 	<ul style="list-style-type: none"> - Consult with Soosan for further inspection.
<ul style="list-style-type: none"> - Abnormal wear and cracks rod. 	<ul style="list-style-type: none"> - rod 	<ul style="list-style-type: none"> - If the rod is deformed, burred and worn out, be repaired. - If the rod is excessively worn out, be replaced. - If the rod is cracked, be replaced.

■ Tightening Torque & Gas Pressure

ITEM	MODE																
	Position	UNIT	SB10II SB20II	SB30II	SB35II	SB40II	SB43II	SB43B	SB45	SB50	SB60	SB70	SB81 SB81A	SB100	SB121 SB130	SB151 SB157 SB160	SB177
Through Bolt Nut	A	kg-m	25~30	25~30	30~35	38~42	60~70	60~70	96 ~105	140 ~150	190 ~200	270 ~280	290 ~300	440 ~450	440 ~450	470 ~480	470 ~480
Accumulator Socket Bolt	B	kg-m	-	-	-	-	-	-	-	-	-	-	60~65	60~65	65~70	65~70	90~95
Accumulator Cover Socket Bolt	C	kg-m	-	-	-	-	-	-	-	-	-	-	45	45	35	35	65
Cap & Plug	D	kg-m	-	-	-	-	15	-	-	-	-	-	15	15	15	15	15
Bracket Fixing Bolt	E	kg-m	60	80	80	100	100	100	145	145	200	250	250	250	350	350	350
Back Head Gas Pressure	F	kg/cm ² (psi)	16,5 (235)	16,5 (235)	16,5 (235)	16,5 (235)	16,5 (235)	16,5 (235)	16,5 (235)	16,5 (235)	16,5 (235)	16,5 (235)	16,5 (235)	16,5 (235)	16,5 (235)	16,5 (235)	16,5 (235)
Accumulator Gas Pressure	D	kg/cm ² (psi)	-	-	-	-	-	10 (142)	-	-	-	-	55 (782)	55 (782)	55 (782)	55 (782)	55 (782)
Air check valve	G	kg-m	16~18	16~18	16~18	16~18	16~18	16~18	16~18	16~18	16~18	16~18	16~18	16~18	16~18	16~18	16~18
Valve Adjust Nut	H	kg-m	-	-	-	-	-	25~30	-	-	25~30	30~35	30~35	30~35	50~55	50~55	60~65
Adapter	I	kg-m	16~18	16~18	16~18	16~18	16~18	16~18	24~26	24~26	32~35	32~35	32~35	32~35	35~40	35~40	35~40
Charging Valve	F	kg-m	35~40	35~40	35~40	35~40	35~40	35~40	35~40	35~40	35~40	35~40	35~40	35~40	35~40	35~40	35~40
Hex Head Plug	J	kg-m	-	-	-	-	-	-	-	-	3~4	3~4	3~4	3~4	3~4	3~4	3~4
Greasing every 1 Hr Using (Manual)	*	cc	7	7	7	10	10	10	10	15	15	20	20	20	25	25	25

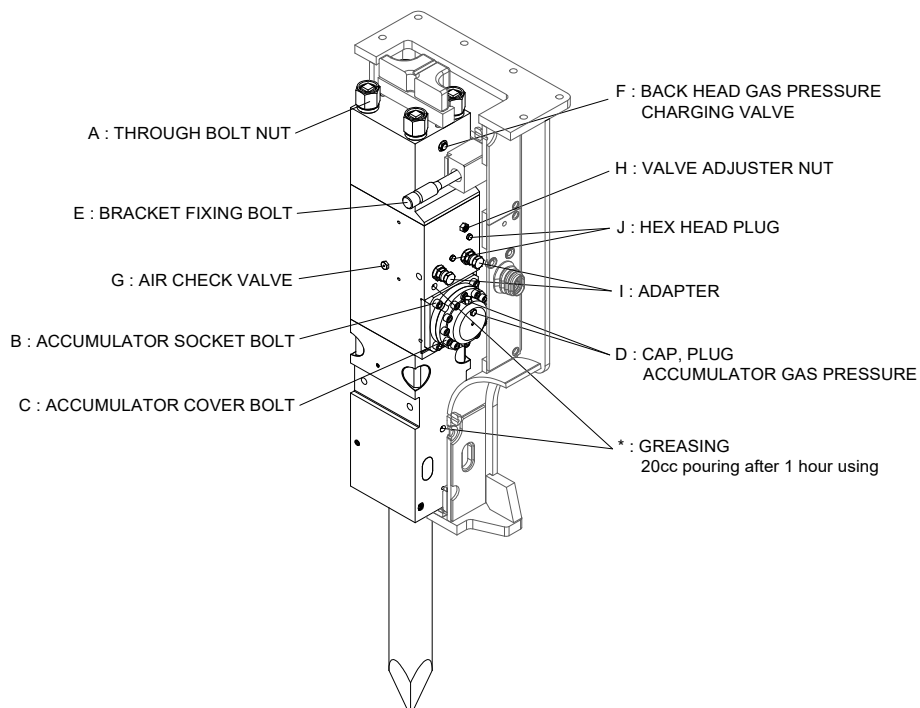

■ Replacement & Breakage of Rod

- Rod is deformed or burrs produced in a long term use.
- If the rod tip is worn out, rod is liable to slip. Grind the rod tip to sharpen the edge.
- If the rod tip is sharpened many times, the hardened surface layer will disappear and the rod will be worn out rapidly. In this case, replace with a new rod.
- If the gap between rod and front cover is large, the piston fail to fit in rod to cause damage to the piston or the rod.

● Replacement

- ① Put the breaker horizontally on the timber.
- ② Remove the spring pin(SB43 below) or rubber plug(SB45 above) using a pin bar.
- ③ Set round bar on the opposite side, and push the stop pin with a hammer.
- ④ Remove the rod pin. In removing the rod pin, be careful falling of rod and rod pin.
- ⑤ Wind rope or nylon sling around the rod and remove from the main body.
- ⑥ Before installing a new rod, check wear, breakage and score.
Remove burrs and swelling from the disassembled rod pin with a grinder. Excessively deformed rod pin will make replacement of rod difficult. Rod pin is required to be checked every 100 to 150 hours of operation
- ⑦ Grease sufficiently to inserting part of front head.

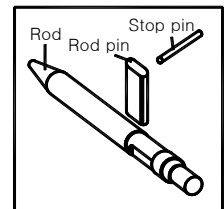
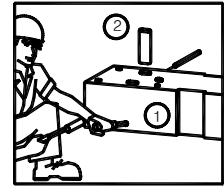

● Breakage of Rod

The service life of the rods depends on the manner of handling them. The rod can sufficiently withstand the vertically acting load, but is weak to the perpendicularly acting load. Especially, the rod is affected by the negative conditions such as force by craning operation, tilted blowing, wrenching and idle strokes etc. There are several ways of breakage of the rod. Each cause of the breakage can be inferred by observing the breakage section. Further, the breakage case which is not caused by low quality materials or insufficient heat-treatment but by wrong way of handling which the manufacturer is not responsible for the breakage. The breakage section has the origin on the outer surface, the narrow area of fatigue breakage and the wide area of rough grey area, and final breakage part has the share-lip form. Such as undulation on the breakage section and its inclination to the right and left witness that the breakage is caused by excessive force which excessive force which exceeds the toughness of the rod. Such the breakage is supposed to occur owing to careless handling of the rod. To avoid such the breakage more carefulness and attention is required in handling the breaker.

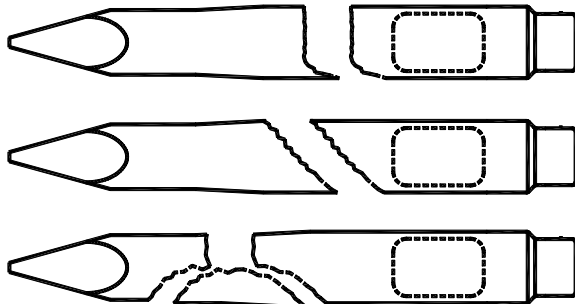

Typical fractures caused by excessive bending of the rod. Warranty claims rejected.

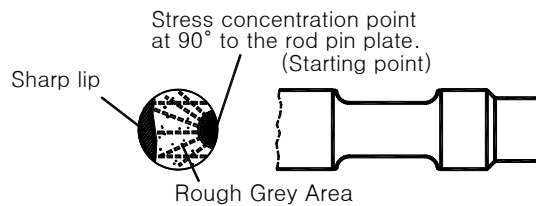

Typical fractures caused by levering tool while buried in the burden. Warranty claims rejected.



Flat type rod worn more than 45mm or moil type and wedge, universal type rods worn back more than 75mm of working end classed as reasonable life. Warranty claims rejected.

■ Assembly and Disassembly of Rubber Plug

In disassembling the front head pin and stop pin, assemble or disassemble with following method.

1) Assembling the rubber

● Method #1

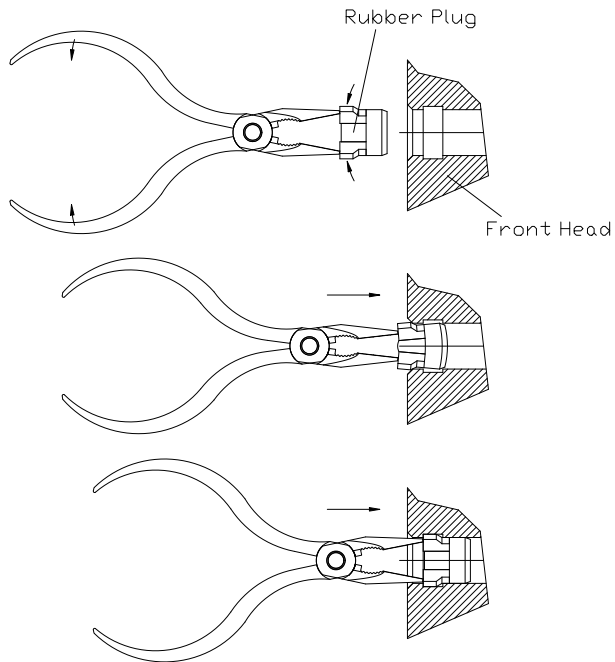

● Method #2

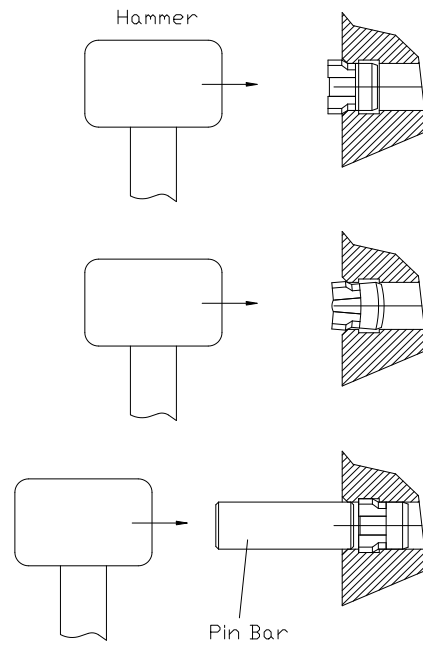

2) Disassembling the rubber plug

● Method #1

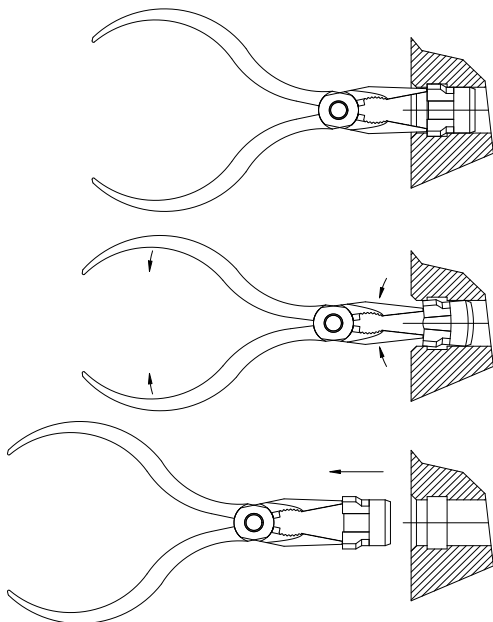

● Method #2

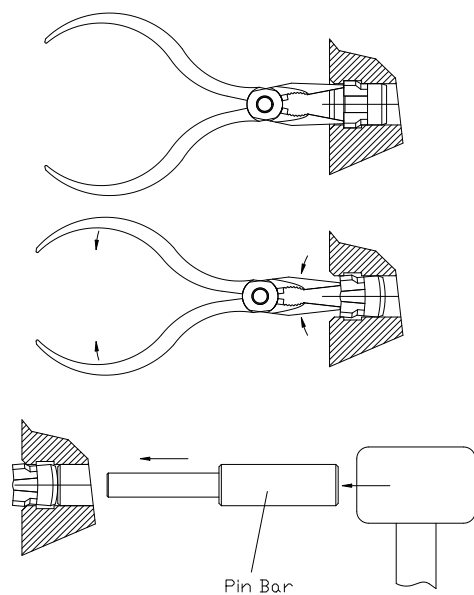

07. Wear Tolerance

Wear tolerance of each kind expendable parts come to decide. The usage of exceeding the wear tolerance causes fatal damage to breaker. Prevent the damage through the regular inspection and exchange of expendable parts including seals and all kinds of bushes. Our company is not responsible for the flaw using in exceeding the wear tolerance of the expendable parts.

7.1 Seal & O-Ring

* Quality Guaranteed Period : 3 months

Since hydraulic breaker operates at high-pressure and high-temperature, leakage or scratch could be occurred by friction, wear and breakage of seals. Considering pressure, temperature, viscosity of oil, a little leakage is accepted to be normal. But in case of abnormal leakage, replace as a new ones. To prevent fatal defect periodical replacement is carried out every 3 months without external leakage of breaker.

Although the breaker is not operated in a long time, replace seals periodically to prevent rust, corrosion of oil and transformation of seals.

7.2 Front cover, Thrust bush

Unit(mm)

	MODEL	New Inside Dia.	Reject Inside Dia.
THRUST BUSH	SB10II	40	42
	SB20II	45	47
	SB30II	53	55
	SB35II	60	62
	SB40II	68	71
	SB43II	75	79
	SB43B	75	79
FRONT COVER	SB45	85	89
	SB50	100	105
	SB60	125	130
	SB70	135	140
	SB81(A)	140	146
	SB100	150	156
	SB121, SB147P	155	161
	SB130	165	171
	SB140, SB147	165	171
	SB151, 157	175	181
	SB160	180	186
	SB177	190	196

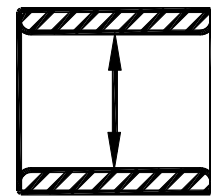

THRUST BUSH
(Measure at center)

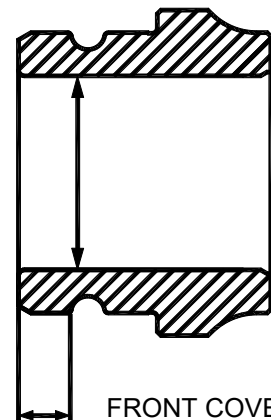

FRONT COVER
(Measure at 10mm)

7.3 Ring bush

MODEL	Unit(mm)			
	New Inside Dia.	Reject Inside Dia.	New B	Reject B
SB10II	40	42	8,75	7
SB20II	45	47	10,25	8
SB30II	53	55	8,5	6
SB35II	60	62	10,5	7,5
SB40II	68	71	10,5	7,5
SB43II	75	78	15	12
SB43B	75	78	15	12
SB45	85	89	24	21
SB50	100	105	17	14
SB60	125	130	31	28
SB70	135	140	32,5	29,5
SB81(A)	140	146	40	37
SB100	150	156	38	35
SB121,SB147P	155	161	46	43
SB130	165	171	41	38
SB140,SB147	165	171	41	38
SB151,157	175	181	53,5	50,5
SB160	180	186	40	37
SB177	190	196	31,5	28,5

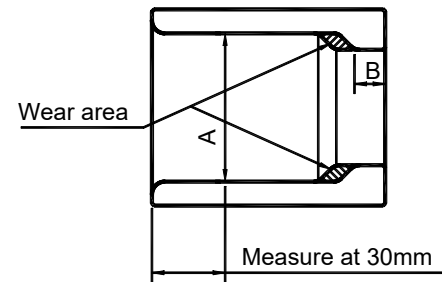

7.4 Rod pin

Unit(mm)

MODEL	NEW Length	REJECT Length
SB10II	28	26
SB20II	28	26
SB30II	32	30
SB35II	36	34
SB40II	38	36
SB43II	42	40
SB43B	42	40
SB45	54	51
SB50	60	57
SB60	75	72
SB70	82	79
SB81(A)	88,5	85,5
SB100	94	91
SB121, 147P	96	93
SB130	96	93
SB140, 147	96	93
SB151, 157	99	95
SB177	110	107

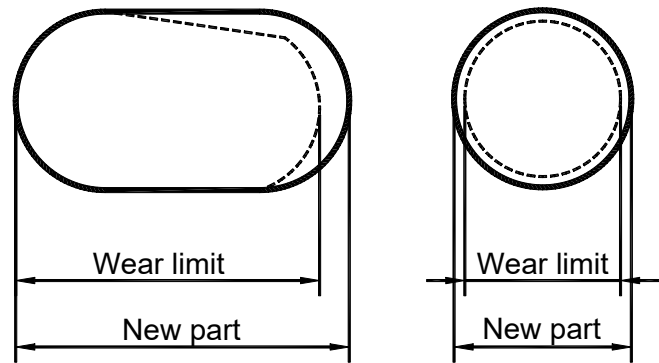

7.5 Stop pin

MODEL	Unit(mm)	
	New Outside Dia	Reject Outside Dia
SB10II	13	11
SB20II	13	11
SB30II	13	11
SB35II	13	11
SB40II	16	14
SB43II	16	14
SB43B	16	14
SB45	17,5	15,5
SB50	17,5	15,5
SB60	17,5	15,5
SB70	17,5	15,5
SB70P/SB81NP	17,5	15,5
SB81(A)	20	18
SB81P/81AP	20	18
SB100, SB121	17,5	15,5
SB130	17,5	15,5
SB140	17,5	15,5
SB151	26	24
SB177	26	24

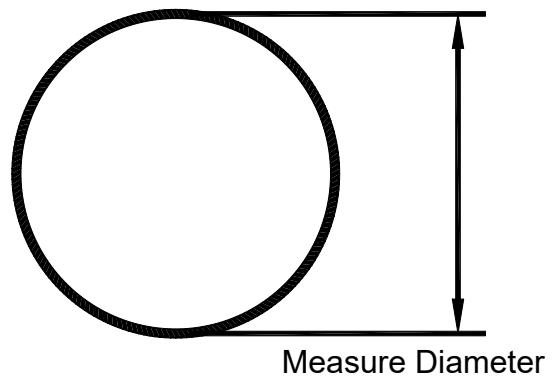

7.6 Front head pin

MODEL	Unit(mm)	
	New Outside Dia	Reject Outside Dia
SB45	20	18
SB50	26	24
SB60	26	24
SB70	26	24
SB81(A)	30	28
SB100	26	24
SB121, SB147P	26	24
SB130	26	24
SB140, 147	26	24
SB151, 157	36	34
SB160	36	34
SB177	36	34

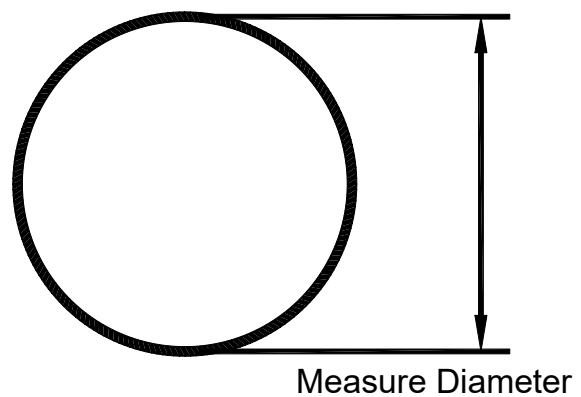

7.7 Rod

MODEL	Unit(mm)		
	New (LONG Type)	New (SHORT Type)	Wear Limit
SB10II	297	247	200
SB20II	326	276	200
SB30II	330	280	200
SB35II	374	324	200
SB40II	425	325	250
SB43II	507	407	250
SB43B	507	407	250
SB45	564	464	250
SB50	561	461	250
SB60	650	550	300
SB70	701	601	350
SB81(A)	762	662	400
SB100	854	754	450
SB121	913	813	500
SB130	952	852	500
SB140, SB147	952,5	852,5	500
SB151, SB157	918	818	550
SB160	918	818	550
SB177	871	776	550

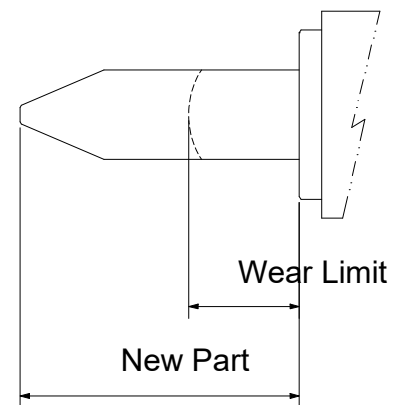

7.8 Piston

MODEL	Unit(mm)	
	New Length	Wear Limit
SB10II	159	158
SB20II	169	168
SB30II	168	167
SB35II	196	195
SB40II	189	188
SB43II	251	250
SB43B	251	250
SB45	285	284
SB50	284	283
SB60	340	338
SB70	318	316
SB81(A)	324	322
SB100	357	355
SB121	385	383
SB130	413	411
SB140	433	431
SB147P	509	507
SB147	489,5	487,5
SB151	518	516
SB157	517	515
SB160	517	515
SB177	578	576

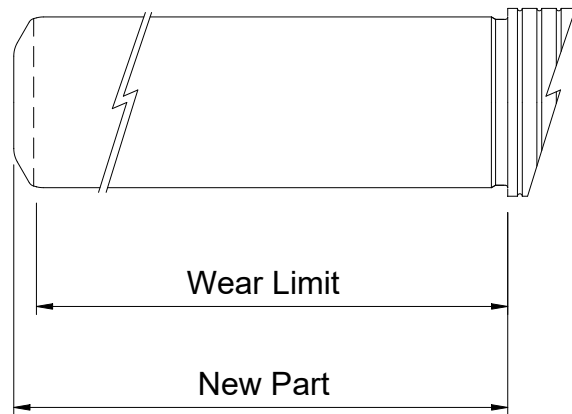

08. Inspection and Charging of N₂ Gas at Back head



WARNING

Charging gas pressure changes according to the rod condition.

Lay down the hammer and let the rod extend fully to charge gas.

Stay clear of the rod while charging the breaker with gas.

The rod may be impacted by the piston and forced out abruptly, when the through bolts are changed or the breaker body is disassembled. Discharge N₂ gas before work.

Take special care to handle and store the N₂ gas cylinder as it is high pressurized container. Use nitrogen gas only.

Back head gas pressure 6kg/cm² (85.5psi) on the back head surface temperature at 20°C(68°F)
See "CONVERSION TABLE FOR CHARGING N₂ GAS PRESSURE TO BACK HEAD"

■ Inspection of N₂ Gas Back Head

- 1) Make sure if the cap and valve of the 3-way valve assembly(5) are fully tightened.
Screw the 3-way valve assembly(5) into the charging valve of the back head after removing the plug.
- 2) At this time the handle must stand up to prevent the gas from coming out.
- 3) Push the handle into the charging valve fully, so the gas pressure inside the back head is indicated on the pressure gauge.
- 4) When the gas pressure is normal, unscrew the 3-way valve assembly after discharging gas inside the 3-way valve assembly.
- 5) When the gas pressure is higher or lower, charge it as described below.

■ Charging of N₂ gas into Back Head

- 1) Connect the charging hose(4) to N₂ gas cylinder(1) after screwing the bombe adapter(3) onto adapter nut(2) and installing them to the N₂ gas cylinder.
- 2) Connect the 3-way valve assembly(5) to the charging hose(4) after unscrewing the cap on the 3-way valve.
- 3) Install the 3-way valve assembly(5) to the charging valve of the Back Head. At this time the handle of the 3-way valve assembly must be up position to prevent the gas from coming out.
- 4) Push the handle of the 3-way valve assembly fully and turn the handle of the N₂ gas cylinder counterclockwise gradually to charge gas.
- 5) When the gas pressure exceeds 10% higher than the specified pressure, close the N₂ gas cylinder by turning the handle clockwise.
- 6) Leave the handle of 3-way valve assembly up. Generated pressure makes it return back to original position naturally.
- 7) In order to discharge N₂ gas in the charging hose(4) and the 3-way valve assembly turn the relief valve counterclockwise.
- 8) Remove the charging hose(4) from the N₂ gas cylinder(1) and the 3-way valve assembly(5), and screw the cap into the 3-way valve assembly.
- 9) Push the handle of the 3-way valve assembly fully, and the gas pressure inside the Back Head is indicated on the pressure gauge. When the pressure is higher, discharge a small amount of gas from the Back Head by repeatedly opening and closing the valve and then gas pressure falls to the specified pressure.
- 10) When the gas pressure reaches to the specified pressure, close the valve and release the handle.
- 11) Open the valve completely and discharge gas inside the 3-way valve assembly.
Remove the 3-way valve assembly from the charging valve of Back Head and install the plug to the charging valve. At this time prevent contamination from entering the breaker.

■ Conversion Table for charging nitrogen gas pressure to Back Head

(Depends on the temperature of Back Head surface)

Back Head Surface Temperature (°C / °F)	0 / 32	10 / 50	20 / 68	30 / 86	40 / 104
Back Head Gas Pressure (kg/cm ² / psi)	15,5 / 220	16 / 228	16,5 / 235	17 / 242	17,5 / 249

■ Back Head Sticker (C02135)

(Appears on the Back Head charging valve)

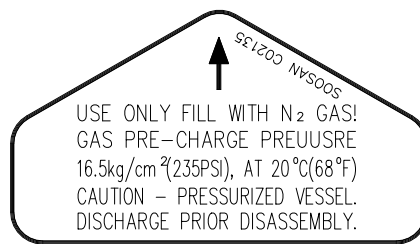

■ N₂ (Nitrogen) Gas charging tools to Back Head

ITEM	PART No.	Q'ty	PART NAME
	C61204	1 SET	N ₂ (Nitrogen) Gas Charging Set
1	2900003	1	N ₂ (Nitrogen) Gas Cylinder
2	C91121	1	Bombe Adapter Nut
3	C91122	1	Bombe Adapter
4	2651001	1	Synflex Hose
5	C01244	1	B-3way Valve Assembly

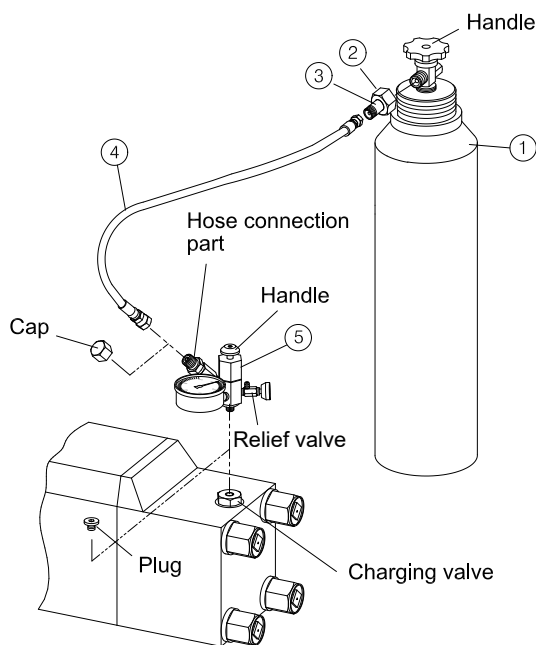

Conversion table for charging N₂ gas pressure to back head

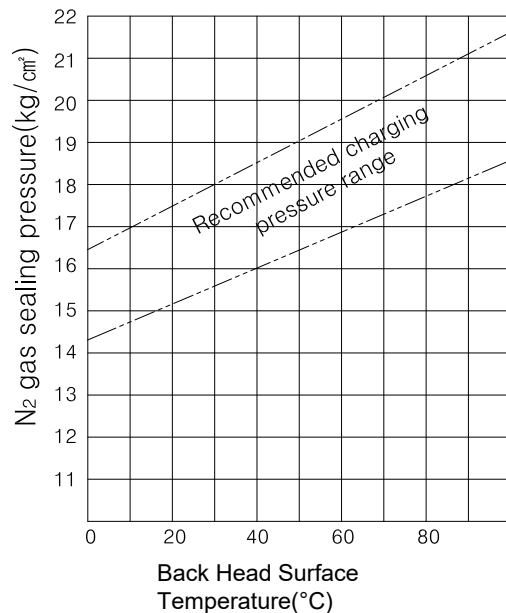

09. Inspection and Charging of N₂ gas in Accumulator



WARNING

Take special care to handle and store the N₂ gas cylinder as it is high pressurized
Use nitrogen gas only.

When disassemble the accumulator, must discharge N₂ gas before working.

Do not touch on the accumulator surface when working.

Be sure to use the 3 way valve assembly for charging the N₂ gas if charging gas leaks directly from the cylinder, diaphragm may be broken off.

If charging for handling N₂ gas to only the accumulator, make sure that the accumulator body and cover are tightened fully.

Standard accumulator gas pressure 55kg/cm² (783psi) on the accumulator surface temperature at 20°C(68°F)

See "CONVERSION TABLE FOR CHARGING N₂ GAS PRESSURE TO BACK HEAD"

■ Inspection of N₂ gas Accumulator.

- 1) Make sure if the cap and valve of the 3-way valve assembly(5) are fully tightened.
- 2) Remove the cap(11) from the accumulator and tighten the charging valve (12) fully.
- 3) Check if O-rings(6)(8) are installed to the bushing(7). Remove the plug(9) and screw the bushing.
- 4) Install the bushing(7) to the 3-way valve assembly(5).
- 5) Loosen the charging valve(12) gradually. The charging pressure is indicated on the pressure gauge.
- 6) Close the valve clockwise when the gas pressure is normal. If the gas pressure is higher, repeat loosening and tightening the relief valve of 3-way valve assembly. The pressure is lowered gradually.
- 7) Loosen the relief valve of the 3-way valve assembly to discharge the N₂ gas in the 3-way valve assembly(5).
- 8) Remove the 3-way valve assembly(5) and tighten the plug(9) and cap(11).

■ Charging of N₂ gas into Accumulator

- 1) Connect the charging hose(4) to N₂ gas cylinder(1) after screwing the bombe adapter(3) onto adapter, nut(2) and installing to the N₂ gas cylinder.
- 2) Connect the 3-way valve assembly(5) to the charging hose(4) after unscrewing the cap on the 3-way valve assembly.
- 3) Remove the cap(11) from the accumulator and tighten the charging valve(12) fully.
- 4) Check if O-rings (6)(8) are installed to the bushing(7). Remove the plug(9) and screw the bushing.
- 5) Loosen the accumulator charging valve(12) after checking if bushing(7) is installed to the 3-way valve assembly.
- 6) Turn the handle of the N₂ gas cylinder counter clockwise slowly to charge gas.
- 7) Charge gas in accordance with the conversion table for charging N₂ gas pressure to accumulator.
- 8) Turn the handle of the N₂ gas cylinder clockwise to close the cock.
- 9) Close the accumulator charging valve(12).
- 10) Loosen the relief valve of the 3-way valve assembly to discharge the N₂ gas remaining in the charging hose.
- 11) Remove the charging hose, 3-way valve assembly and bushing and tighten the plug(9) and cap(11).

■ Conversion Table for charging nitrogen gas pressure to Accumulator

Accumulator Surface Temperature (°C / °Fμ)	0 / 32	10 / 50	20 / 68	30 / 86	40 / 104
Accumulator Gas Pressure (kg/cm ² / psi)	51 / 730	53 / 755	55 / 780	57 / 815	59 / 830

- Accumulator(A) Sticker (C62212)
 - appears on the accumulator body

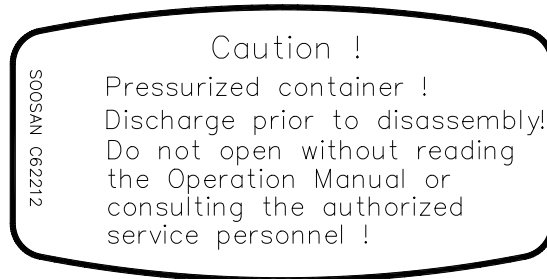

- Accumulator(B) Sticker (C62213)
 - appears on the accumulator body

Date of construction	
Temperature(Max)	80 C°/175 F°
Volume	1.7 l
Fill Material	Only nitrogen gas
ACCUMULATOR PRECHARGE PRESSURE	55kg/cm 780psi (at 20 C°/68 F°)

SOOSAN C62213

■ N₂ (Nitrogen) gas Charging Tools to Accumulator

ITEM	PART No.	Q'ty	Part Name
1	2900003	1	N ₂ Gas Cylinder
2	C91122	1	Bombe Adapter
3	C91121	1	Bombe Adapter Nut
4	2651001	1	Synflex Hose
5	C01244	1	B-3 Way Valve Assembly
6	2850010	1	O-Ring
7	U81414	1	O-Ring Hex Bushing
8	2850014	1	O-Ring

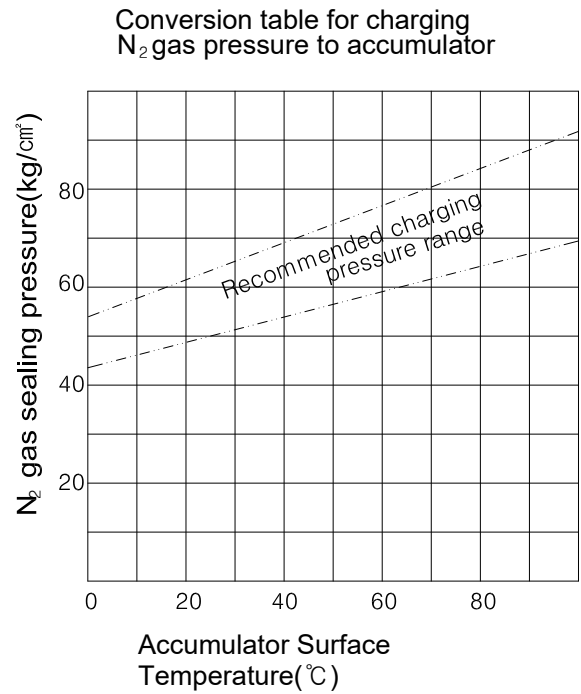
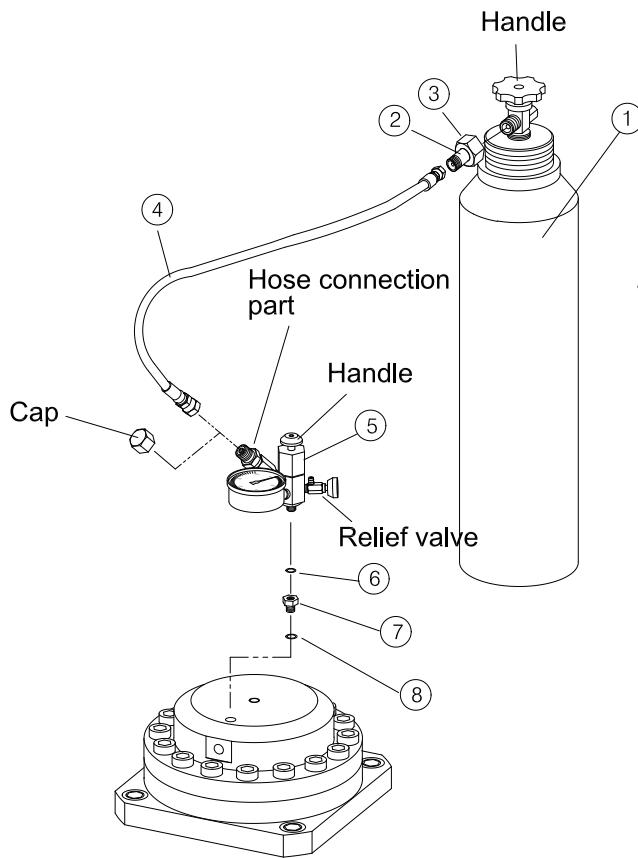

10. Trouble Shooting

The trouble-shooting chart is prepared to help operators find out causes and remedies instantly when troubles occur. When a trouble is found, have a good grip of the problem and contact our service station.

When diagnosing faults in operation of the breaker, always check that hydraulic power source is supplying the correct hydraulic flow and pressure to the breaker as listed in the table.

Check the flow with the hydraulic oil temperature at least 176°F/80°C. An approved test procedure is available from Soosan.

TROUBLE	CAUSE	REMEDY
<p>1. Breaker fails to hammer</p> <ul style="list-style-type: none"> * Sufficient high pressure oil does not flow to breaker inlet, * Sufficient high pressure oil flows to breaker inlet, 	<ul style="list-style-type: none"> * Defective hose or pipes * Clogged or damaged piping * Defective control valve and related parts * Insufficient hydraulic oil * Internal breaker defects 	<ul style="list-style-type: none"> * Check, clean and repair piping or replace with new one, * Check and repair valve and its related parts or replace with new one, * Refill oil tank, * Consult with our service station,
<p>2. Breaker hammers with hammering force reduced,</p> <ul style="list-style-type: none"> * Sufficient high pressure oil does not flow to breaker inlet, * Sufficient high pressure oil flows to breaker inlet, 	<ul style="list-style-type: none"> * Defective hose or pipes Clogged piping, Oil leakage * Defective control valve and related parts * Deformed pedal * Deformed control valve * Stuck control valve * Insufficient control valve stroke due to loose screws * Clogged filter in return line of base machine tank * Insufficient hydraulic oil * Contaminated or deteriorated hydraulic oil * Defective pump * Internal breaker defects * low N₂-gas pressure of back head 	<ul style="list-style-type: none"> * Check, clean and repair piping or replace with new one, * Check control valve and related parts or replace with new one, * Clean or replace, * Refill, * After flushing tank, change oil entirely, * Ask service station for base machine service, * Consult with our service station, * Adjust the gas pressure referring to Chapter 10,
<p>3. Hammering force weakens suddenly and high pressure hose vibrates excessively during operation,</p>	<ul style="list-style-type: none"> * Defective Back Head Gas leakage 	<ul style="list-style-type: none"> * Ask our service station for repair,
<p>4. Excessive oil leakage from Front Head or Rod,</p>	<ul style="list-style-type: none"> * Worn cylinder seals 	<ul style="list-style-type: none"> * Ask our service station for repair,
<p>5. Piston works but does not hammer,</p>	<ul style="list-style-type: none"> * Stuck in rod 	<ul style="list-style-type: none"> * Remove front parts and pull out rod, * Repair with a grindstone,

※ Ask base machine service station to repair defective base machine.

11. Hydraulic Oil

Selection of hydraulic oil determines the efficiency of the hydraulic breaker performance.

Please consult with our service station under following conditions.

- (1) When used in special regions where climate is severe (extremely cold or hot weather)
- (2) When recommended brands of hydraulic oil are not available
- (3) When hydraulic oil supplied for the base machine differ from the recommended one.

■ Hydraulic Oil and Grease

Recommended for Hydraulic Grab by Soosan

LUBE & SPEC	HYDRAULIC OIL			GREASE
	SUMMER	WINTER	ALL SEASON	(MOS2)
Manufacturer	ISO VG 46	ISO VG 32	ISO VG 46	NLGI No2
	MOBIL DTE 25	MOBIL DTE 24	MOBIL DTE 15M	MOBIL GREASE SPECIAL
MOBIL	MOBIL SHC 525 *			MOBILITH SHC 220 *
	MOBIL EAL SYNDRAULIC 46 **			
LG-CALTEX	RANDOHD 46	RANDO HD 32	NEW RANDO HDCZ	MOLYTEX EP2
BP	ENERGOL HP46	ENERGOL HP32	ENERGOL HP46	-
SHELL	TELLUS 46	TELLUS 32	TELLUS T 46	RETINAX HDX-2
S-OIL	-	-	AZOLLA ZS 46	-

★: Synthetic Lubricant

★★: Environmentally Friendly Synthetic Lubricant

■ Oil Contamination

Contaminated oil results in malfunctions of the breaker as well as the base machine and causes damage to parts. Pay special attention to oil contamination.

Contaminated oil should be changed without delay. When changing oil, thoroughly wash oil tank, cylinder and pipes. Cleaning or replacing oil filter also requires check for oil contamination.

※ Replacement of filter : after first 50 hours and every 100 hours thereafter

※ Replacement of hydraulic oil : every 500 hours



WARNING

Hydraulic oil Temperature and viscosity

Do operate the hydraulic breaker at oil temperatures from 20°C/68°F to 80°C/176°F.

Operation at higher temperatures can damage the internal components of the breaker and carrier there will result in reduced breaker performance.

■ Criterion of Oil Contamination and Malfunction

(General Analysis)

Analysis Item	Criterion	Causes and Effects when exceed the criterion
Adhesiveness	Within $\pm 10\%$ (40°C cst)	Adhesiveness rarely decreases because of hydraulic oil, Entry of different kind of oil may reduce the adhesiveness which contributes to rising oil temperature , wear and scratch of bearing and gear and malfunction of hydraulic oil.
Oxidizing Level	Less than 0,3 (mg KOH/g)	Use of lubricating oil in a long period or in a high temperature (above 60°C) will oxidize it, Oxidizing level rises as oxidization proceeds, Sludge will be produced during the process and it leads to malfunction, corrosion and ageing.
Moisture	Less than 0,1(%)	Moisture causes rust, wear and scratch, Moisture of 0,3% goes considerably rusty and moisture of 0,5% occurs the damage of machine.

■ Criterion of Oil Malfunction by Hydraulic Oil Color

(Simple discrimination by ASTM color)

Hydraulic oil turns black as the breaker fails to display best performance. The old oil is assumed to be contaminated when there is a visual difference between the old new oil color and functions begin to deteriorate when hydraulic oil turns darker than the new oil color (ASTM number) by more than two.

12. The Auto Lubrication Kit(Option)

- Install the auto lubrication kit before using it.
- Use only recommended lubricant, if not the lubricant useless.
- For the sake of the auto lubrication, the grease adapter is supplied as standard parts.
- Don't lubricate excessively, the lubricant will be leaked through the air check valve.
- Don't use fluid grease, but use only recommended lubricant.

■ Installing the Auto lubrication kit

- 1) Clean surface area of the grease nipple hole on the Cylinder(or Front head).
- 2) Remove the Grease nipple form the Cylinder(or Front head).
- 3) Apply the O-ring to the G adapter and install it on the Cylinder(or Front head).
- 4) Connect the 1/4" Hose to the G adapter.

■ Grease Filling Quantity (when Auto Lubrication kit installed)

Model	No.	Part No.	Part Name
ALL MODEL	1	2851018	O-Ring
	2	C01 157	G-Adapter
	3	2551042	Hose
	4	2700403	Grease Nipple

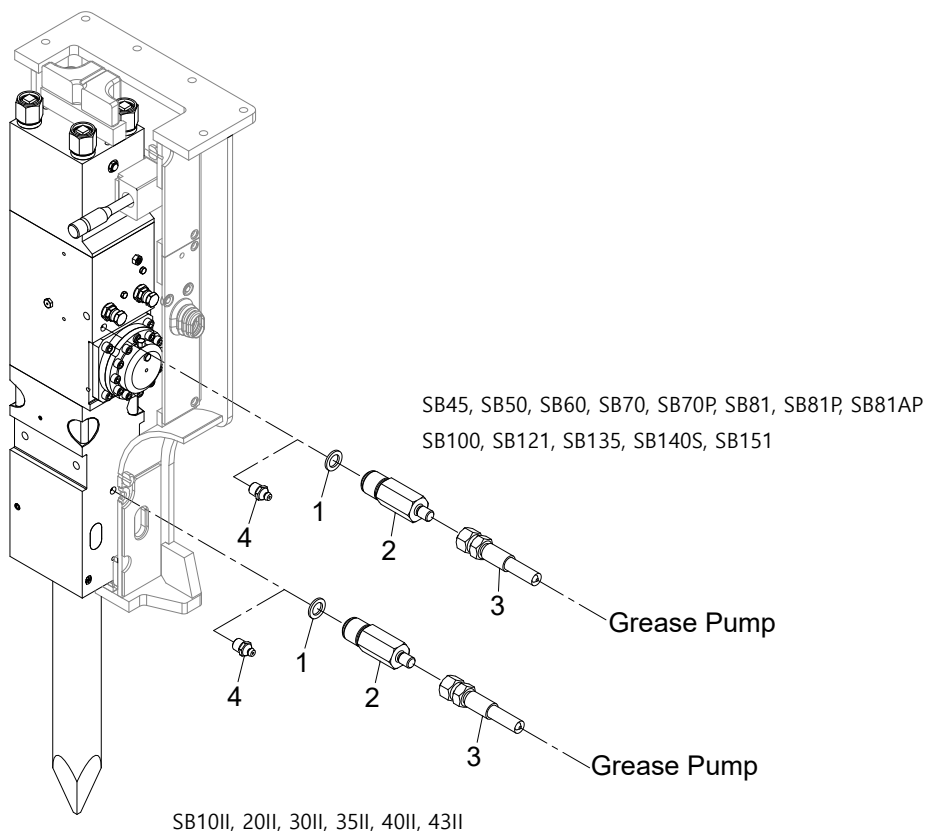

■ Auto lubrication kit installed in carrier (SB10II ~ SB177)

No	Part No.	Q'ty	Part Name
-	B0000499	1	GREASE PUMP KIT
1	B0000500	1SET	GREASE PUMP
2	B0000501	10M	ELECT WIRE
3	B0000502	2	FERRULE BOLT
4	B0000503	2	FERRULE NUT
5	B0000504	1	STRAGHT NIPPLE
6	B0000505	1SET	STICK ARM
7	B0000506	1	SOCKET
8	B0000507	1	NIPPLE
9	B0000508	1	COUPLING PLUG
10	B0000509	1	COUPLING SOCKET
11	B0000510	1	HOSE
12	4011037	2	HEXAGON WRENCH BOLT
13	4211008	2	SPRING WASHER
14	B0000511	20M	HIGH PRESS HOSE
15	B0000512	20EA	CABLE TIE

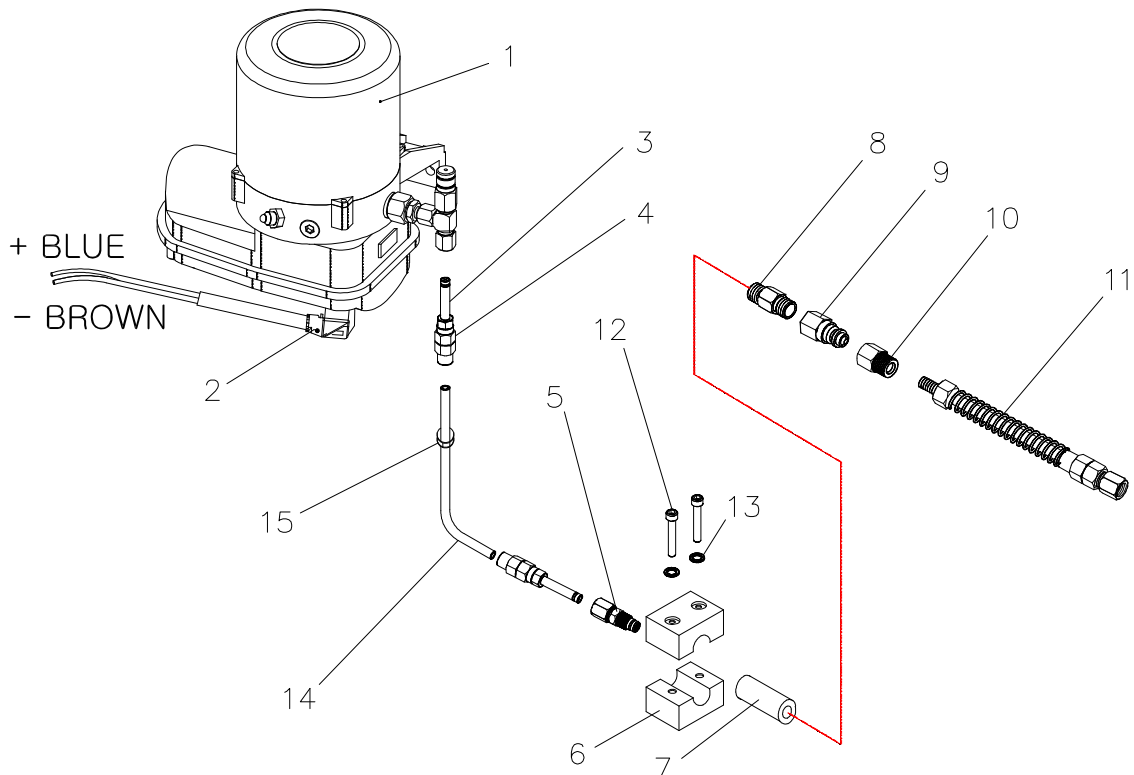

■ Auto lubrication kit installed in breaker (SB60~SB160) (LINCOLN)

Part Name	Q'ty	PartNo. (SB60~SB160)							
		SB60 (#2164~)	SB70 (#3005~)	SB81 (#2164~) SB81A (#5236~)	SB100 (#1388~)	SB121 (#4457~)	SB130 (#3083~)	SB140, SB147 (#816~) SB147P	SB151, SB157 (#830~) SB160
Auto lubrication Kit	1	C75 027	←	←	←	C75 028	←	←	←
FRAME ASS'Y	1	C23 054	L03 008	C33 093	E93 011	C63 062	D83 028	L23 006	C73 023
1. GREASING PUMP	1	C75 002	←	←	←	←	←	←	←
2. Oil HOSE(low)	1	E93 371	←	←	←	E93 372	←	←	←
3. Oil HOSE(high)	1	E93 372	←	←	←	E93 345	←	←	←
4. Oil HOSE (grease)	1	E93 372	←	←	←	E93 345	←	←	←
5. SOCKET BOLT	2	4010120	←	←	←	←	←	←	←
6. H/LOCK ADAPTER	3	C75 110	←	←	←	←	←	←	←
7. H/ADAPTER-01	1	E93 366	←	←	←	←	←	←	←
8. O-RING	1	2851018	←	←	←	←	←	←	←

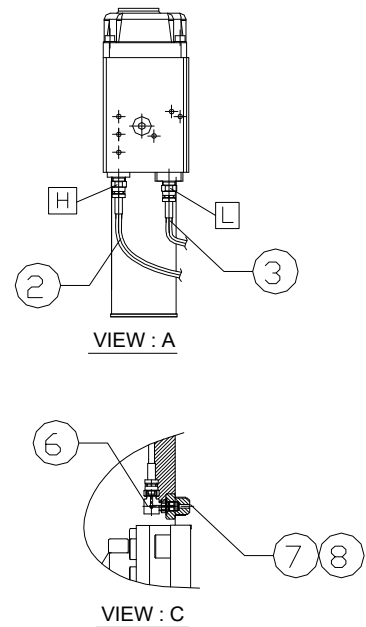
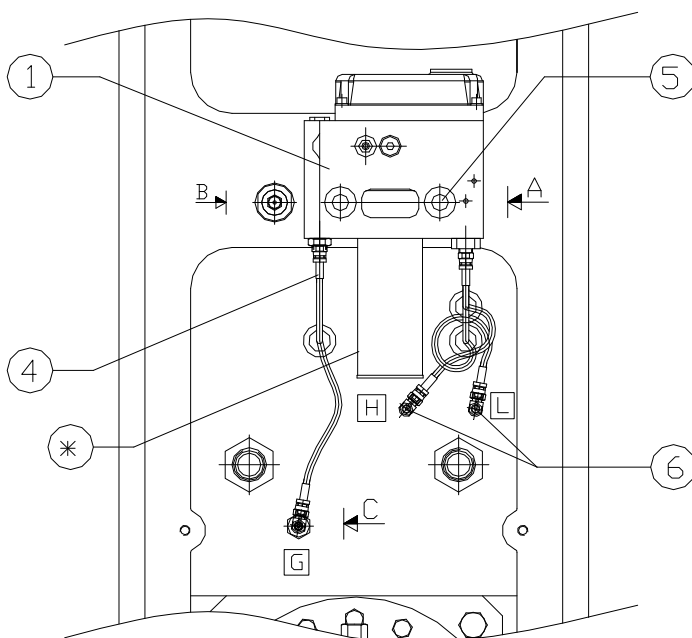

■ Auto lubrication kit installed in breaker (SB60~SB160) (BEKA)

Part Name	Q'ty	Part No. (SB60~SB151)							
		SB60	SB70	SB81 SB81A	SB100	SB121	SB130	SB140 SB147 SB147P	SB151 SB157 SB160
1. Auto lubrication Kit	1	Q15002	Q15002	Q15002	Q15002	Q15002	Q15002	Q15002	Q15002
2. Cartridge	1	Q15003	Q15003	Q15003	Q15003	Q15003	Q15003	Q15003	Q15003
3. Oil Hose	3	Q15008	Q15010	Q15010	Q15012	Q15012	Q15012	Q15013	Q15013
4. Adapter	3	Q15004	Q15004	Q15004	Q15004	Q15004	Q15004	Q15004	Q15004
5. MC Plate	1	Q15015	Q15015	Q15015	Q15015	Q15015	Q15015	Q15015	Q15015
6. Socket Bolt	2	4011120	4011120	4011120	4011120	4011120	4011120	4011120	4011120
7. Cable Tie	2	7101018	7101018	7101018	7101018	7101018	7101018	7101018	7101018
8. Cable Tie	6	7101011	7101011	7101011	7101011	7101011	7101011	7101011	7101011

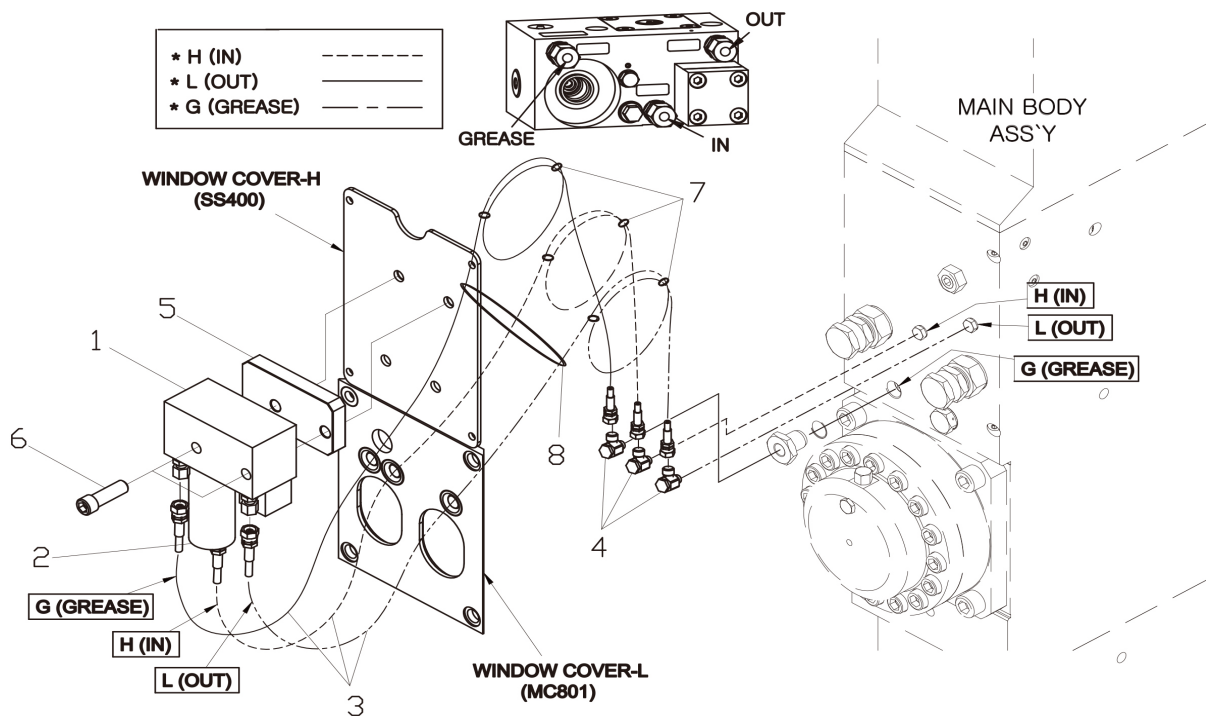

■ Auto lubrication kit installed in breaker (SB60~SB157) (TR-F BEKA)

Part Name	Q'ty	Part No. (SB60~SB157)							
		SB60	SB70	SB81 SB81A	SB100	SB121	SB130	SB140 SB147	SB151 SB157
FRAME ASS'Y	1	C23073	L03035	C33066	E93057	C63085	D83047	L23048 T53008	C73090 T73008
1. GREASING PUMP	1	Q15002	Q15002	Q15002	Q15002	Q15002	Q15002	Q15002	Q15002
2. Cartridge	1	Q15003	Q15003	Q15003	Q15003	Q15003	Q15003	Q15003	Q15003
3. Oil Hose	3	Q15020	Q15020	Q15021	Q15022	Q15023	Q15023	Q15005	Q15005
4. Adapter	3	Q15004	Q15004	Q15004	Q15004	Q15004	Q15004	Q15004	Q15004
5. Support Bar	1	C23602	L03295	C33826	E93378	C63539	L23226	L23226 L23371	C73461 C73598
6. Socket Bolt	2	4011377	4011377	4011377	4011377	4011377	4011377	4011377	4011377
7. Grease Adapter	1	E96366	E96366	E96366	E96366	E96366	E96366	E96366	E96366
8. O-Ring	1	2851018	2851018	2851018	2851018	2851018	2851018	2851018	2851018

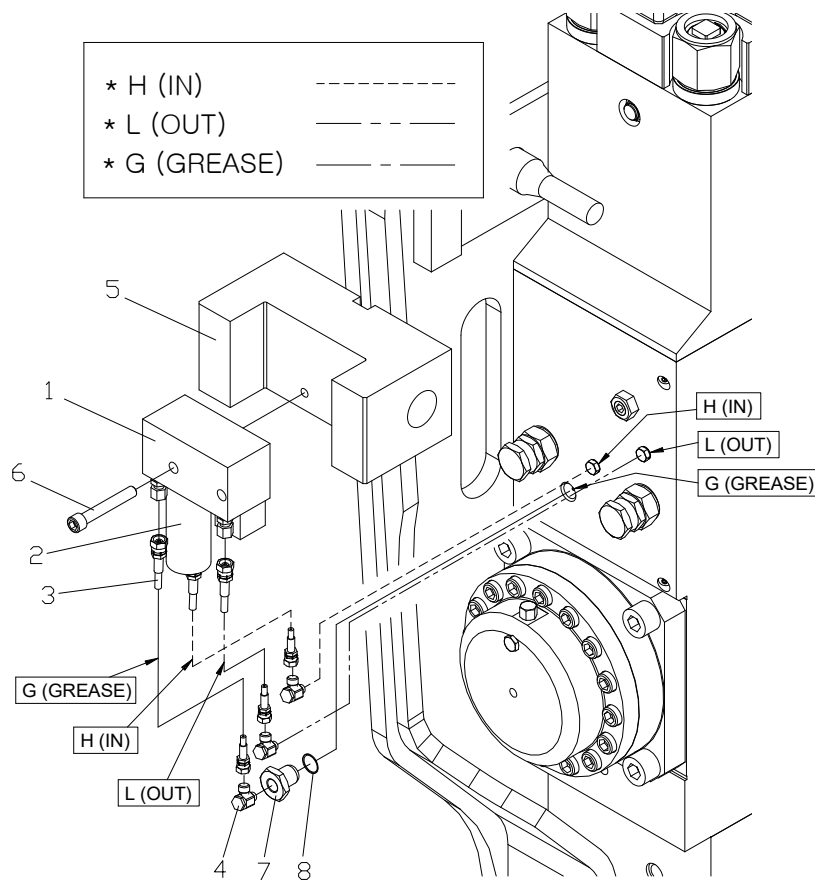

13. Underwater Operation of the Breaker(Optional)

- Underwater operation of the breaker is possible to pour air into the striking area between the piston and the rod.
- For the sake of underwater operation the adapter is supplied as a standard part.
- For the sake of underwater operation the breaker is installed the air supply kit separately.
- Underwater usage of the breaker without the underwater kit and air compressor will cause serious damage to the hydraulic breaker.

■ Installing the Air supply kit

- 1) Clean the air check valve hole on the left-side of the cylinder.
(Except SB40, the air check valve hole is located on the right-side)
- 2) Remove the air check valve with the standard tool.
- 3) Apply the O-ring to the cylinder's air check valve hole and install it.
- 4) Connect the hose to the air check valve hole and install it.
- 5) Before underwater operation, the breaker get into water pouring air into air check valve.

■ Air flow rate for underwater operation

The air capacity levels are in the following chart. Supply appropriate air flow rate in accordance with the breaker model and operating depth.

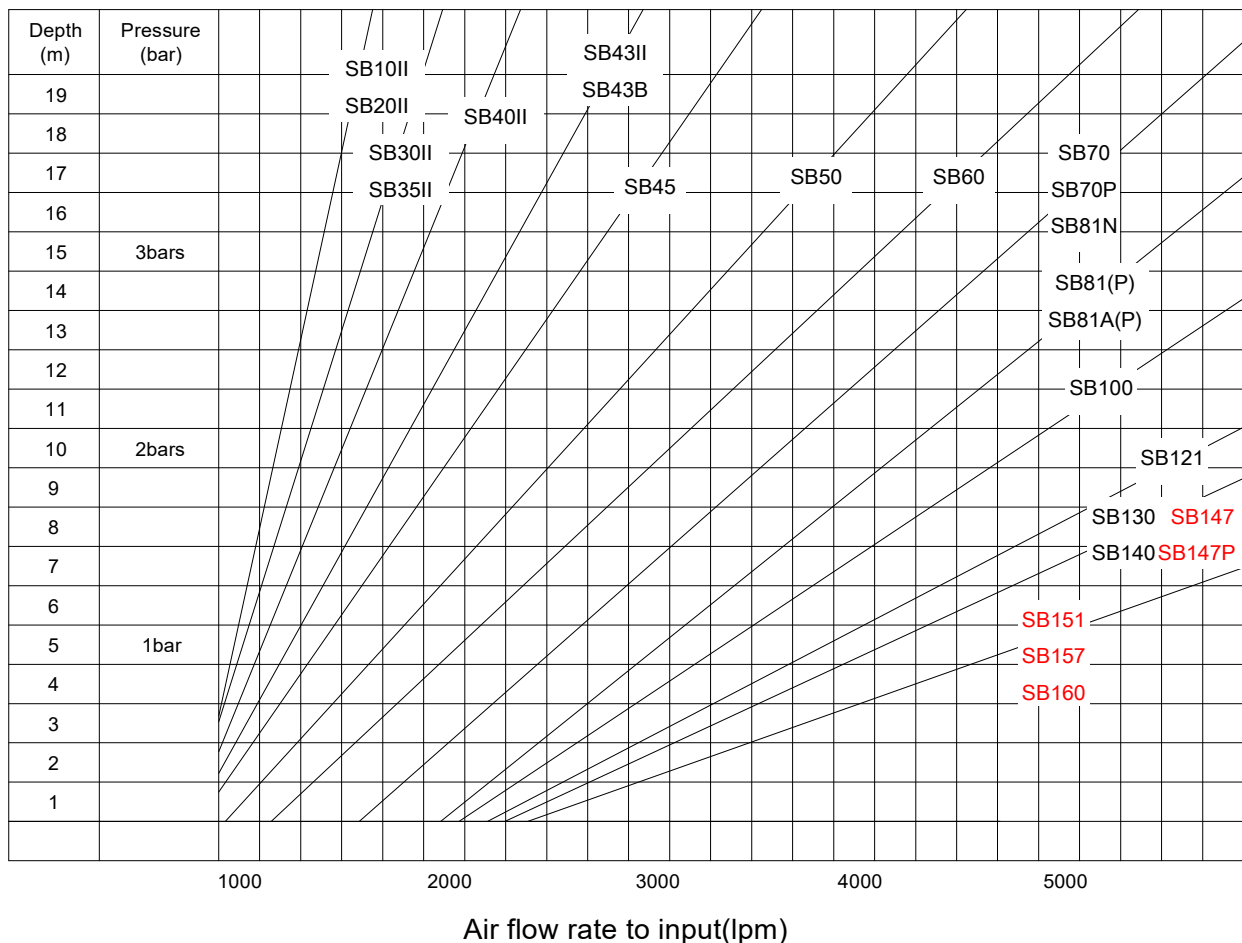

■ Illustration for installing Underwater Breaker(SB10II ~ SB195H)

No	Part No.	Part Name	Q'ty
1	2850017	O-Ring	1
2	C01 158	W-Adapter	1
3	2551242	Hose	1
4	C01 162	Air Check Valve	1

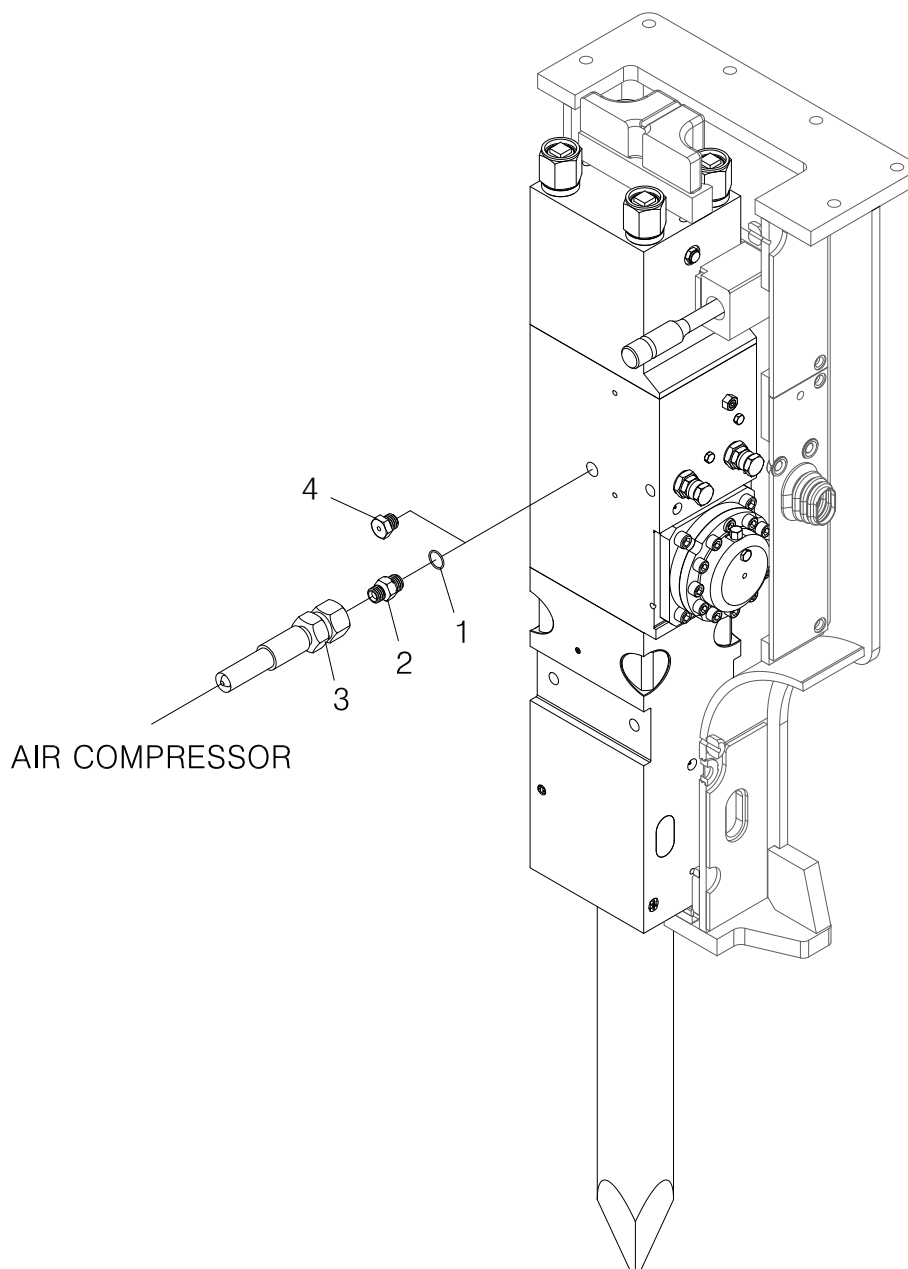

MAINTENANCE FOLLOW-UP

In order to follow the maintenance of a hydraulic breaker, a maintenance card presented below can be used



HYDRAULIC BREAKER SERVICE CARD NO. _____

Equipment

S/No. _____

Model type

S/No. _____

SERVICE INFORMATION

Purpose of the service		Serviceman	
Service Date		Engine working hours	

Replaced parts			Part inspection				
Qty	Description	Part No.	Description	S/No.	Repaired	Replaced	OK
			Cylinder		<input type="checkbox"/>	<input type="checkbox"/>	<input type="checkbox"/>
			Motor		<input type="checkbox"/>	<input type="checkbox"/>	<input type="checkbox"/>
					<input type="checkbox"/>	<input type="checkbox"/>	<input type="checkbox"/>
					<input type="checkbox"/>	<input type="checkbox"/>	<input type="checkbox"/>
					<input type="checkbox"/>	<input type="checkbox"/>	<input type="checkbox"/>
					<input type="checkbox"/>	<input type="checkbox"/>	<input type="checkbox"/>
					<input type="checkbox"/>	<input type="checkbox"/>	<input type="checkbox"/>
					<input type="checkbox"/>	<input type="checkbox"/>	<input type="checkbox"/>
					<input type="checkbox"/>	<input type="checkbox"/>	<input type="checkbox"/>
					<input type="checkbox"/>	<input type="checkbox"/>	<input type="checkbox"/>
					<input type="checkbox"/>	<input type="checkbox"/>	<input type="checkbox"/>
					<input type="checkbox"/>	<input type="checkbox"/>	<input type="checkbox"/>
					<input type="checkbox"/>	<input type="checkbox"/>	<input type="checkbox"/>

Percussion

mechanism tested

Rotation

mechanism tested

Remarks

PARTS BOOK

Soosan Hydraulic Breaker



FOREWORD

This parts list is composed of all parts of SB Series breaker.

If you want to order parts, write down the followings and contact near service center.

- a. Model Name :
- b. Model Serial No. :
- c. Parts No. and Parts Name :
- d. Quantity :
- e. Customer's Name and Address :

Please use genuine parts of SOOSAN to maintain the machine performance as a new one.

Take notice that SOOSAN won't guarantee the defects which may occur by using different parts from SOOSAN genuine parts.

→ For the contents of this parts list, alteration is reserved without prior notice for the future improvement.

SOOSAN HEAVY INDUSTRIES CO., LTD.

01. Main Body

■ SB10 II, 20 II, 30 II, 35 II, 40 II, 43 II

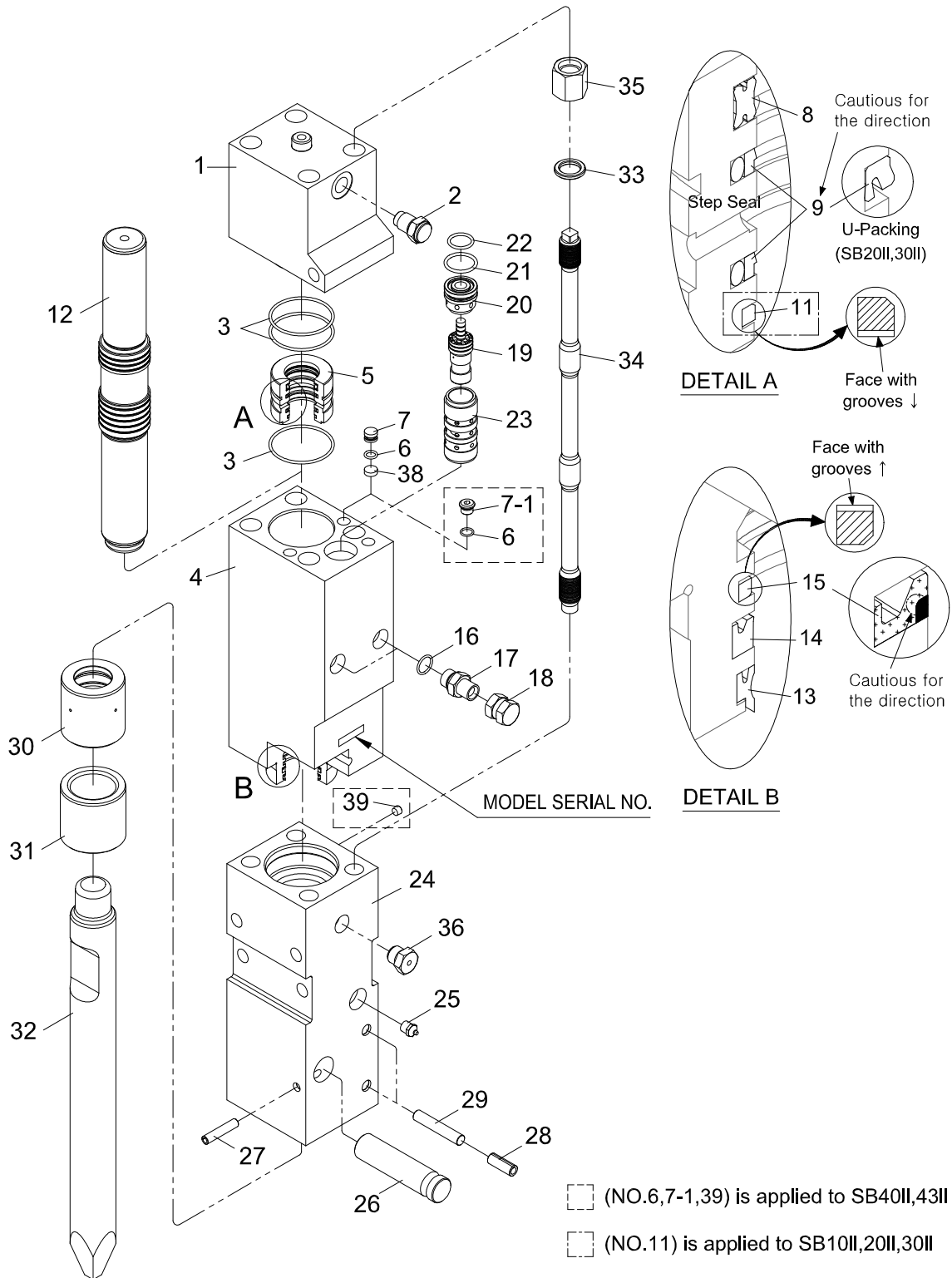

■ MAIN BODY (SB10Ⅱ, 20Ⅱ, 30Ⅱ, 35Ⅱ, 40Ⅱ, 43Ⅱ)

NO	SB10Ⅱ (#116~)		SB20Ⅱ (#532~)		SB30Ⅱ (#425~)		SB35Ⅱ (#95~)		SB40Ⅱ (#7116~)		SB43Ⅱ (#98~)		PART NAME	REMARK
	P/N	Q' t y	P/N	Q' t y	P/N	Q' t y	P/N	Q' t y	P/N	Q' t y	P/N	Q' t y		
1	E81002	1Set	F01002	1Set	E71002	1Set	F81002	1Set	C01005	1Set	F91002	1Set	Main Body Ass'y	
2	E81104	1	F01108	1	E71134	1	F81104	1	C01102	1	F91104	1	Back Head	
3	C51191	1	←	1	←	1	←	1	←	1	←	1	Charging Valve	
4	2851208	3	2851209	3	2851210	3	2851214	3	2856012	3	2851216	3	O-Ring	
5	E81101	1	F01101	1	E71132	1	F81101	1	C01198	1	F91101	1	Cylinder	
6	E81109	1	F01110	1	E71138	1	F81109	1	C91125	1	F91109	1	Seal Retainer	
7	2850010	3	←	3	←	3	2850014	3	2850016	3	←	3	O-ring	
8	F01129	3	←	3	←	3	F81115	3	-	-	-	-	Plug	
7-1	-	-	-	-	-	-	-	-	C91124	3	←	3	Socket Plug	
9	2835035	1	2835036	1	2835037	1	2835038	1	2835039	1	2835040	1	Gas Seal	
10	2811044	2	2811017	2	2811018	2	2811045	2	2811046	2	2811047	2	Step Seal	U-Packing
11	-	-	-	-	-	-	-	-	-	-	-	-	O-Ring	No Use
12	2819063	1	2819061	1	2819059	1	-	-	-	-	-	-	Buffer Seal	
13	E81179	1	F01184	1	E71187	1	F81167	1	C01235	1	F91186	1	Piston	
14	2831057	1	2831058	1	2831013	1	2831063	1	2831022	1	2831017	1	Dust Seal	
15	2811055	1	2811056	1	2811010	1	2811060	1	2811031	1	2811009	1	U-Packing	
16	2819062	1	2819060	1	2819058	1	2833011	1	2819056	1	2833012	1	Buffer Seal	
17	2851018	2	←	2	←	2	←	2	←	2	←	2	O-Ring	
18	C91120	2	←	2	←	2	←	2	←	2	←	2	Adapter	
19	2715002	2	←	2	←	2	←	2	←	2	←	2	Union Cap	
20	F01104	1	←	1	E71105	1	←	1	C01127	1	F91106	1	Valve	
21	F01106	1	←	1	E71140	1	←	1	C01188	1	F91108	1	Valve Plug	
22	2851030	1	←	1	2851033	1	←	1	2851204	1	←	1	O-Ring	
23	2851201	1	←	1	←	1	←	1	←	1	←	1	O-Ring	
24	F01105	1	←	1	E71139	1	←	1	C01193	1	F91107	1	Valve Sleeve	
25	E81136	1	F01152	1	E71156	1	F81132	1	C01216	1	F91142	1	Front Head	
26	2700411	1	←	1	←	1	←	1	←	1	←	1	Grease Nipple	
27	E81139	1	F01155	1	E71158	1	F81134	1	C01219	1	F91143	1	Rod Pin	
28	4300132	1	←	1	←	1	4300150	1	C91151	1	←	1	Spring Pin	
29	4300141	2	4300143	2	←	2	←	2	C91110	2	←	2	Spring Pin	
30	E81140	2	F81135	2	←	2	←	2	C01131	2	F91121	2	Stop Pin	
31	E81138	1	F01153	1	E71157	1	F81133	1	SSC01217	1	F91110	1	Ring Bush	
32	E81137	1	F01154	1	E71159	1	F81111	1	C01218	1	F91111	1	Thrust Bush	
33	SSE81141	1	SSF01156	1	SSE71160	1	SSF81136	1	SSC01220	1	SSF91144	1	Rod(Moil Point)	
34	E81120	4	F01115	4	E71116	4	←	4	C01144	4	F91114	4	Washer	
35	E81118	4	F01114	4	E71114	4	F81112	4	C01145	4	F91112	4	Through Bolt	
36	E81119	4	F01116	4	E71115	4	←	4	C01143	4	F91113	4	Hex Nut	
37	C01162	1	←	1	←	1	←	1	←	1	←	1	Air Check Valve	
38	-	-	-	-	-	-	-	-	-	-	-	-	O-ring	Not Use
39	F01128	3	←	3	←	3	F81114	3	-	-	-	-	Cover Plate	
40	-	-	-	-	-	-	-	-	2702221	1	←	1	Hollow Hex Plug	

■ SB43B

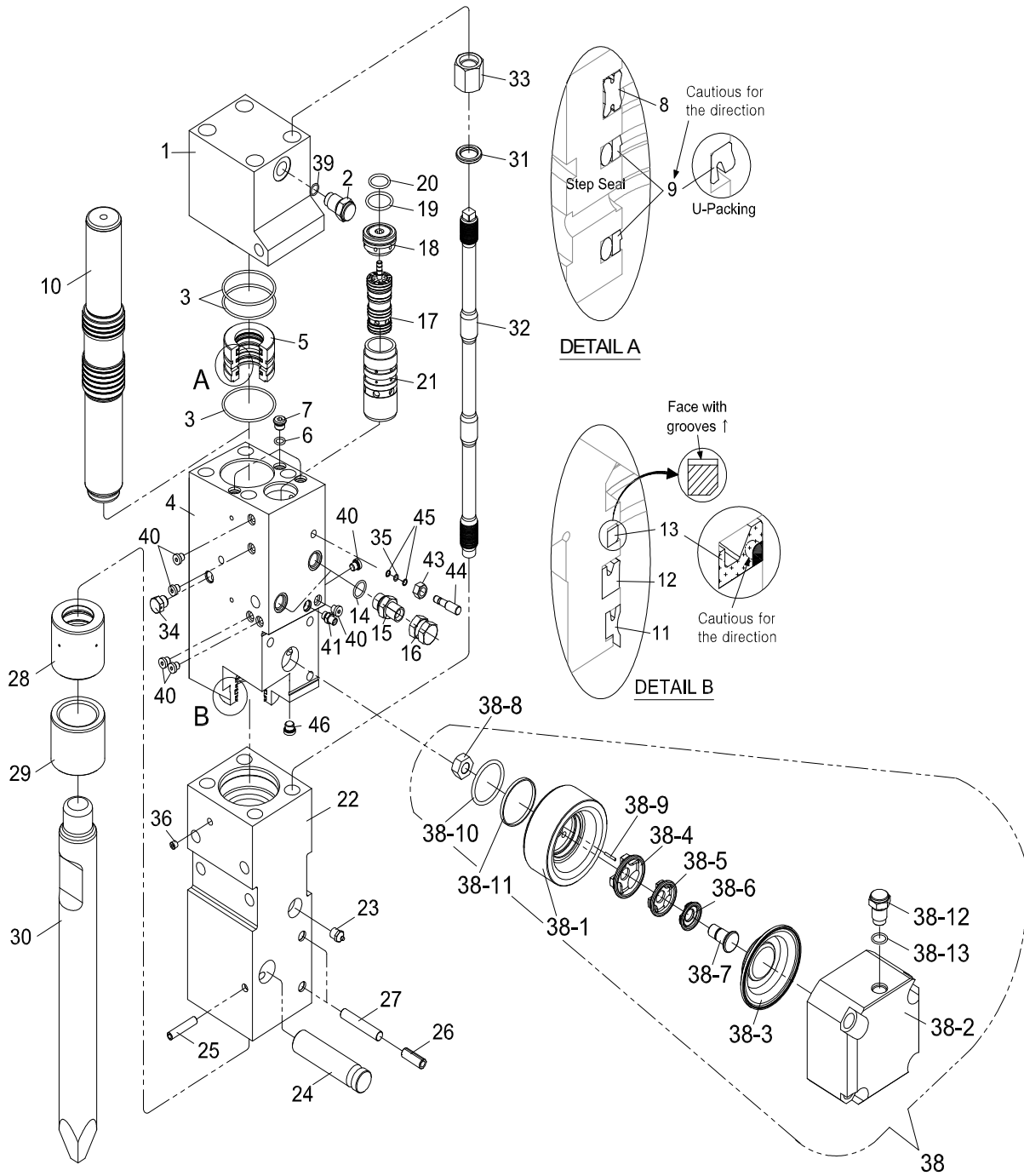

■ MAIN BODY (SB43B)

NO	SB43B		PARTS NAME	REMARK
	P/N	Q'ty		
	F91 003	1Set	Main Body Ass'y	
1	F91 303	1	Back Head	
2	C51 191	1	Charging Valve	
3	2851216	3	O-Ring	
4	F91 302	1	Cylinder	
5	F91 109	1	Seal Retainer	
6	2850016	3	O-Ring	
7	C91 124	3	Socket Plug	
8	2835040	1	Gas Seal	
9	2811047	2	Step Seal	U-Packing
10	F91186	1	Piston	
11	2831017	1	Dust Seal	
12	2811009	1	U-Packing	
13	2833012	1	Buffer Seal	
14	2851022	2	O-Ring	
15	2710311	2	Adapter	
16	2715003	2	Union Cap	
17	C21 108	1	Valve	
18	C21 107	1	Valve Plug	
19	2851208	1	O-Ring	
20	2851205	1	O-Ring	
21	C21 109	1	Valve Sleeve	
22	F91 142	1	Front Head	
23	2700411	1	Grease Nipple	
24	F91 143	1	Rod Pin	
25	C91 151	1	Spring Pin	
26	C91 110	2	Spring Pin	
27	F91 121	2	Stop Pin	
28	F91 110	1	Ring Bush	
29	F91 111	1	Thrust Bush	
30	SSF91144	1	Rod(Moil Point)	
31	F91 114	4	Washer	
32	F91 112	4	Through Bolt	
33	F91 113	4	Hex Nut	
34	C01 162	1	Air Check Valve	
35	2851007	1	O-Ring	
36	2702221	1	Hollow Hex Plug	
37	4130039	4	Helix Sert Coil	
38	F91 304	1	Accumulator Ass' y	
-1	F91 306	1	Accumulator Body	
-2	F91 305	1	Accumulator Cover	
-3	D91 145	1	Diaphragm	
-4	C61 141	1	Holder-A	
-5	C61 142	1	Holder-B	

■ SB43B

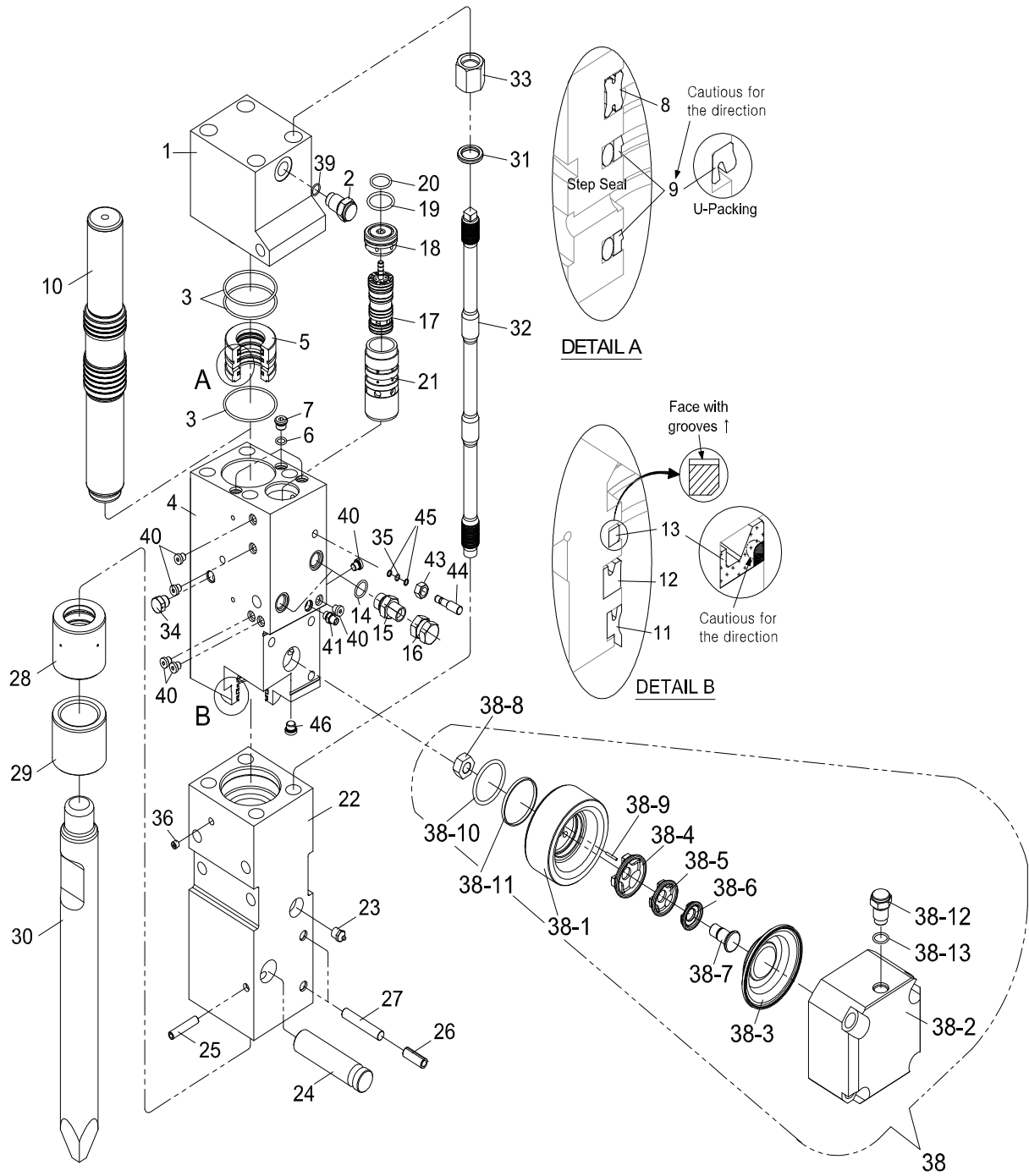

■ MAIN BODY (SB43B)

NO	SB43B		PARTS NAME	REMARK
	P/N	Q'ty		
	F91 003	1Set	Main Body Ass'y	
-6	C61 143	1	Holder-C	
-7	C61 144	1	Holder Pin	
-8	U81 338	1	Holder Nut	
-9	C61 145	1	Center Pin	
-10	2851051	1	O-Ring	
-11	2844901	1	Back-Up Ring	
-12	C51 191	1	Charging Valve Ass' y	
-13	2850017	1	O-Ring	
39	2850017	1	O-Ring	
40	N57 100	6	Blank Plug	
41	F91 307	1	Relief Valve	
42	4011153	4	Socket Bolt	
43	4100305	1	Hex Nut	
44	C21 149	1	Valve Adjuster	
45	2841218	2	Back-Up Ring	
46	N57 101	1	Blank Plug	

■ SB45,50

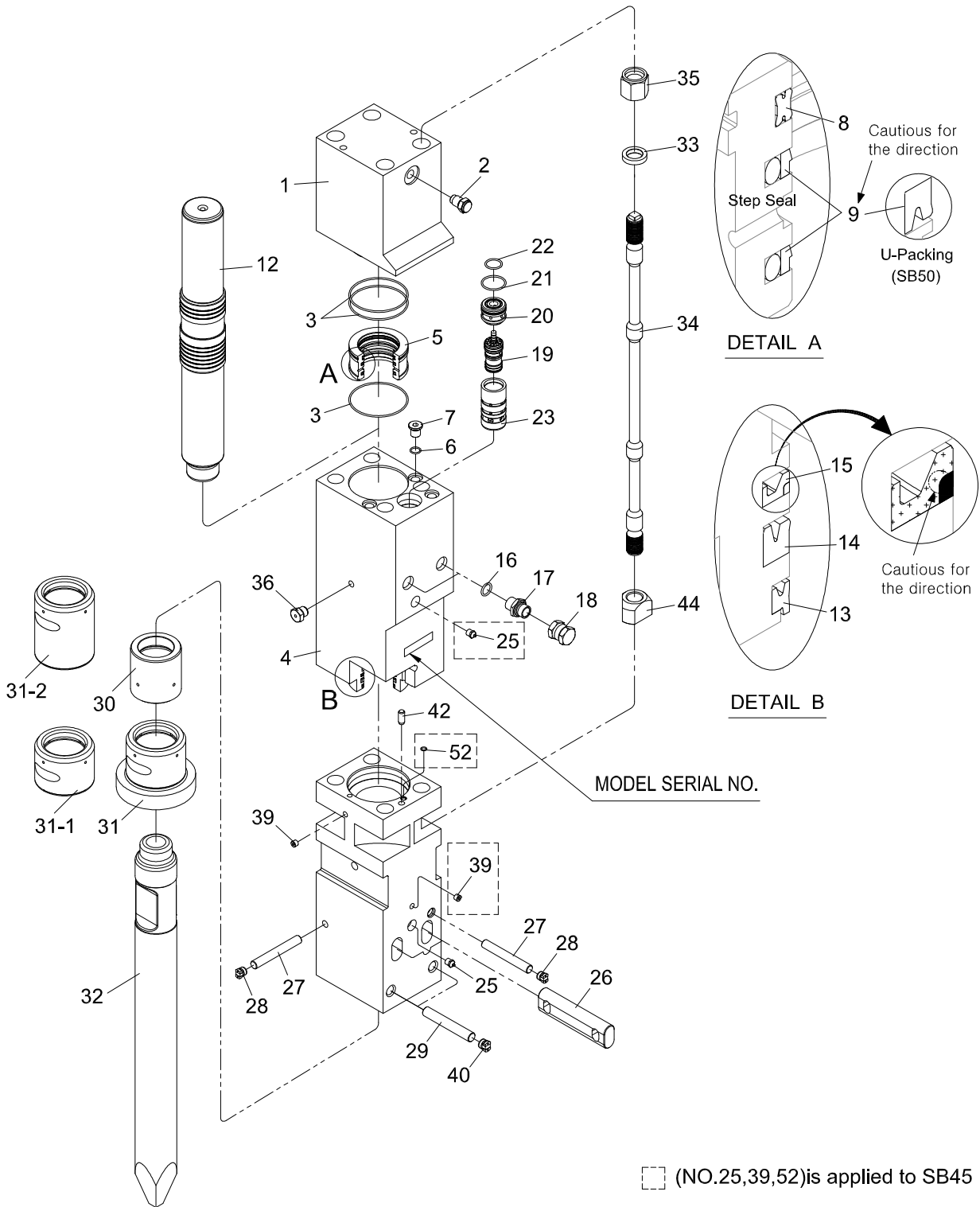

□ (NO.25,39,52)is applied to SB45

■ MAIN BODY (SB45,50)

NO	SB45		SB50		PARTS NAME	REMARK
	P/N	Q'ty	P/N	Q'ty		
1	D41001	1Set	C11003	1Set	Main Body Ass'y	
2	D41110	1	C11112	1	Back Head	
3	C51191	1	←	1	Charging Valve	
4	2851219	3	2851223	3	O-Ring	
5	D41106	1	C11192	1	Cylinder	
6	D41108	1	C11119	1	Seal Retainer	
7	2850017	5	2850020	3	O-Ring	
8	D41109	3	C11120	3	Socket Plug	
9	2835041	1	2835042	1	Gas Seal	
10	2811048	2	2811067	2	Step Seal	U-Packing
11	-	-	2850017	2	O-Ring	Charging Valve
12	-	-	-	-	Buffer Seal	Not Use
13	D41190	1	C11284	1	Piston	
14	2831068	1	2831912	1	Dust Seal	
15	2811064	1	2821018	1	U-Packing	
16	2833001	1	2833015	1	Buffer Seal	
17	2851022	2	←	2	O-Ring	
18	2710311	2	←	2	Adapter	
19	2715003	2	←	2	Union Cap	
20	D41113	1	C11123	1	Valve	
21	D41111	1	C11184	1	Valve Plug	
22	2851205	1	2851051	1	O-Ring	
23	2851202	1	2851203	1	O-Ring	
24	D41112	1	C11183	1	Valve Sleeve	
25	D41148	1	C11193	1	Front Head	
26	2700411	2	2700411	1	Grease Nipple	
27	D41147	2	C11186	2	Rod Pin	
28	D41119	2	C11131	2	Stop Pin	
29	D81151	2	←	2	Rubber Plug	
30	D41118	2	C11128	2	Front Head Pin	
31	SSD41141	1	SSC11182	1	Ring Bush	
31-1	SSD41187	1	SSC11270	1	Front Cover	Side
31-2	SSD41142	1	SSC11181	1	Front Cover	Side Silence, TS-P
32	-	1	SSC11266	1	Front Cover	TR-F
33	SSD41101	1	SSC11195	1	Rod(Moil Point)	
34	D41115	4	C11141	4	Washer	
35	D41160	4	C11220	4	Through Bolt	
36	D41161	4	C11221	4	Hex Nut	
37	C01162	1	←	1	Air Check Valve	
38	-	-	-	-	O-Ring	Not Use
39	-	-	-	-	O-Ring	Not Use
40	2702221	2	←	1	Hollow Hex Plug	
41	C31246	2	D81150	2	Rubber Plug	
42	-	-	-	-	Snap Ring	Not Use
43	U81278	1	←	1	Knock Pin	
44	-	-	-	-	Hex Head Plug	Not Use
45	D41162	4	C11222	4	Round Nut	
46	-	-	-	-	O-Ring	Not Use
47	-	-	-	-	Back-Up Ring	Not Use
48	-	-	-	-	Valve Adjuster	Not Use
49	-	-	-	-	Nut	Not Use
50	-	-	-	-	Socket Plug	Not Use
51	-	-	-	-	Square Ring	Not Use
52	-	-	-	-	Socket Plug	Not Use
52	2851007	1	-	-	O-Ring	

■ SB60,70,81

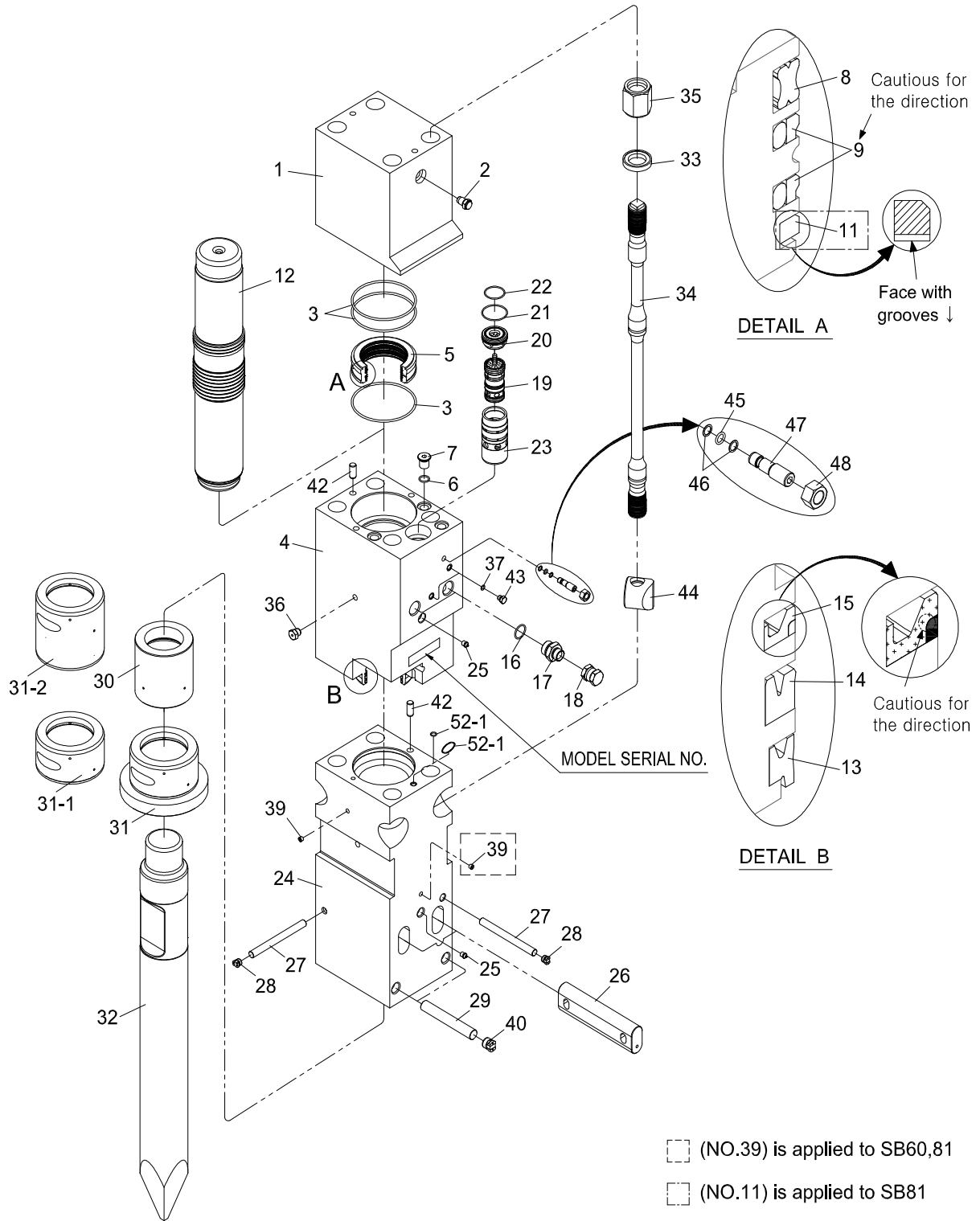

■ MAIN BODY (SB60,70,81NII,81)

NO	SB60 (#851~)		SB70 (#666~)		SB81N II (#4750~)		SB81 (#3033~)		PARTS NAME	REMARK
	P/N	Q'ty	P/N	Q'ty	P/N	Q'ty	P/N	Q'ty		
	C21 002	1Set	L01 004	1Set	L01 005	1Set	C31 007	1Set	Main Body Ass'y	
1	C21 101	1	L01 104	1	←	1	C31 101	1	Back Head	
2	C51 191	1	←	1	←	1	←	1	Charging Valve	
3	2851226	3	2851229	3	←	3	2851232	3	O-Ring	
4	C21 102	1	L01 141	1	←	1	C31 207	1	Cylinder	
5	C21 104	1	L01 109	1	←	1	C31 111	1	Seal Retainer	
6	2850021	3	←	3	←	3	2850024	3	O-Ring	
7	C21 106	3	←	3	←	3	C31 123	3	Socket Plug	
8	2835043	1	2835034	1	←	1	2835044	1	Gas Seal	
9	2811049	2	2811066	2	2811015	2	2811076	2	Step Seal	
10	—	—	—	—	—	—	—	—	O-Ring	Not Use
11	—	—	—	—	—	—	2819051	1	Buffer Seal	
12	C21 172	1	L01 146	1	←	1	C31 255	1	Piston	
13	2831073	1	2831040	1	←	1	2831041	1	Dust Seal	
14	2811007	1	2811089	1	←	1	2811090	1	U-Packing	
15	2833019	1	2833013	1	←	1	2833003	1	Buffer Seal	
16	2851028	2	←	2	←	2	2851038	2	O-Ring	
17	2710315	2	←	2	←	2	C31 193	2	Adapter	
18	2715004	2	←	2	←	2	←	2	Union Cap	
19	C21 108	1	L01 106	1	←	1	C31 171	1	Valve	
20	C21 107	1	L01 108	1	←	1	C31 172	1	Valve Plug	
21	2851208	1	2851209	1	←	1	2851210	1	O-Ring	
22	2851205	1	2851206	1	←	1	2851207	1	O-Ring	
23	C21 109	1	L01 107	1	←	1	C31 173	1	Valve Sleeve	
24	C21 174	1	L01 147	1	L01 193	1	C31 256	1	Front Head	
25	2700411	2	←	2	←	2	←	2	Grease Nipple	
26	C21 153	2	L01 116	2	←	2	C31 226	2	Rod Pin	
27	C21 115	2	←	2	E91 121	2	C31 127	2	Stop Pin	
28	D81 151	2	←	2	←	2	C31 246	2	Rubber Plug	
29	C21 113	2	E91 120	2	←	2	C31 126	2	Front Head Pin	
30	SSC21151	1	SSL01110	1	SSL01110	1	SSC31225	1	Ring Bush	
31	SSC21219	1	SSL01200	1	SSC31440	1	SS31440	1	Front Cover	
31-1	SSC21146	1	SSL01123	1	SSL01123	1	SSC31185	1	Front Cover	Side Silence
31-2	SSC21162	1	SSL01198	1	SSL01198	1	SSC31240	1	Front Cover	TR-F,TS-P
32	SSC21114	1	SSL01118	1	SSL01118	1	SSC31211	1	Rod(Moil Point)	
33	C21 118	4	L01 115	4	←	4	C31 140	4	Washer	
34	C21 189	4	L01 168	4	←	4	C31 271	4	Through Bolt	
35	C21 190	4	L01 169	4	←	4	C31 272	4	Hex Nut	
36	C01 162	1	←	1	←	1	←	1	Air Check Valve	
37	2851010	2	←	3	←	3	←	3	O-Ring	
38	—	—	—	—	—	—	—	—	O-Ring	Not Use
39	2702221	2	←	1	←	1	←	2	Hollow Hex Plug	
40	D81 150	2	←	2	←	2	C31 247	2	Rubber Plug	
41	—	—	—	—	—	—	—	—	Snap Ring	Not Use
42	C21 173	2	←	2	←	2	←	2	Knock Pin	
43	Q11 191	2	←	2	←	2	←	2	Hex Head Plug	
44	C21 175	4	L01 148	4	←	4	C31 257	4	Round Nut	
45	2851007	1	(=NO. 37)	(1)	←	(1)	(←)	(1)	O-Ring	
46	2841218	2	2841217	2	←	2	←	2	Back-Up Ring	
47	C21 149	1	C31 210	1	←	1	←	1	Valve Adjuster	
48	4101305	1	4101306	1	←	1	←	1	Nut	
49	—	—	—	—	—	—	—	—	Socket Plug	Not Use
50	—	—	—	—	—	—	—	—	Square Ring	Not Use
51	—	—	—	—	—	—	—	—	Socket Plug	Not Use
52	2851014	1	←	1	←	1	←	1	O-Ring	

SB81A,100,100II,121

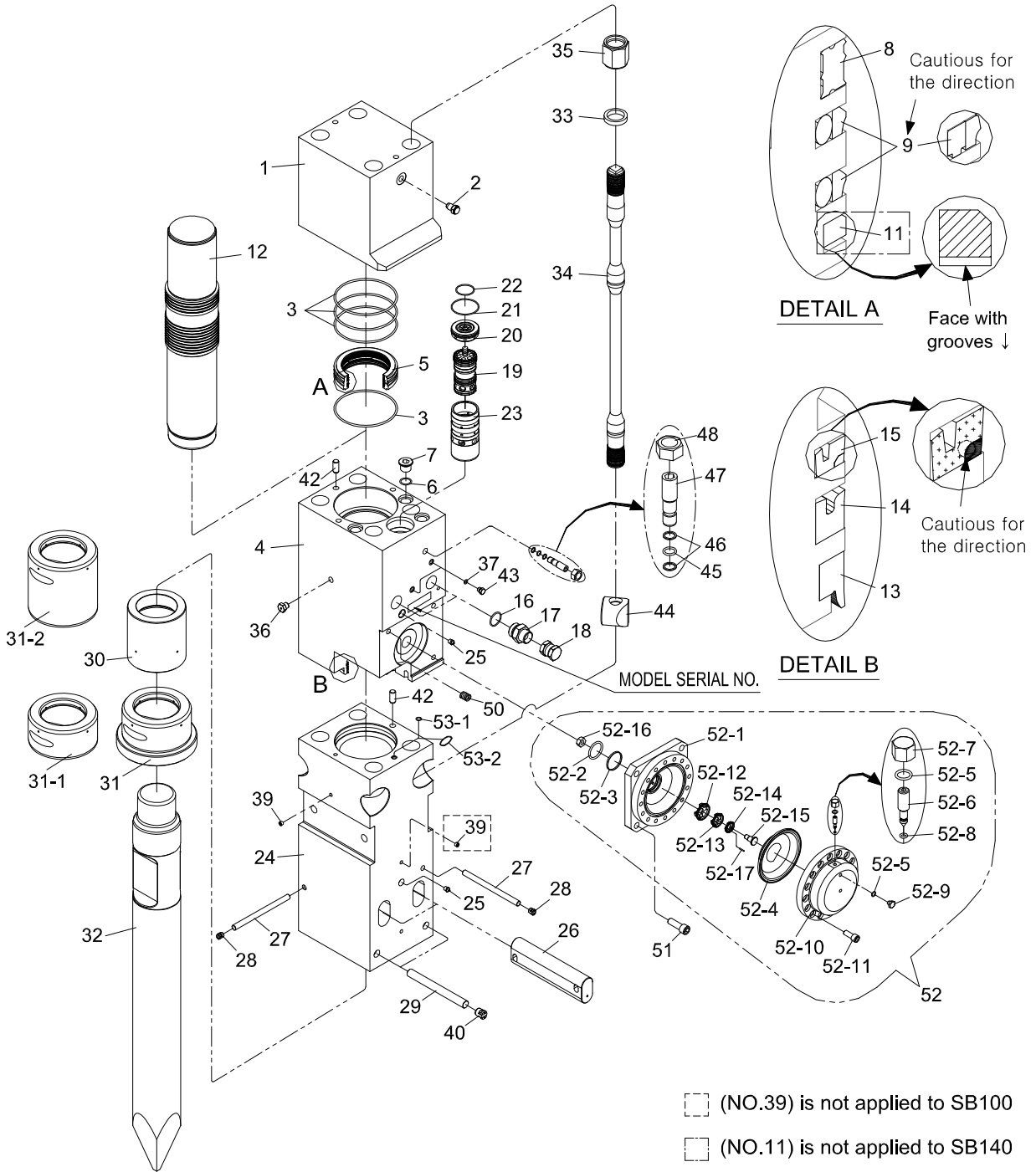

■ MAIN BODY (SB81A,100,100II,121)

NO	SB81A (#2993~)		SB100 (#261~)		SB100II (#2060~)		SB121 (#2321~)		PARTS NAME	REMARK
	P/N	Q'ty	P/N	Q'ty	P/N	Q'ty	P/N	P/N		
	C31008	1Set	E91002	1Set	E91003	1Set	C61006	1Set	Main Body Ass'y	
1	C31101	1	E91105	1	←	1	C61121	1	Back Head	
2	C51191	1	←	1	←	1	←	1	Charging Valve	
3	2851232	3	2851234	3	←	3	2851235	4	O-Ring	
4	C31216	1	E91101	1	←	1	C61225	1	Cylinder	
5	C31111	1	E91110	1	←	1	C61131	1	Seal Retainer	
6	2850024	3	←	3	←	3	2850033	3	O-Ring	
7	C31123	3	←	3	←	3	C61146	3	Socket Plug	
8	2835044	1	2835045	1	←	1	2835046	1	Gas Seal	
9	2811076	2	2811077	2	←	2	2811078	2	Step Seal	
10	-	-	-	-	-	-	-	-	O-Ring	Not Use
11	2819051	1	2819052	-	2819052	-	2819053	1	Buffer Seal	
12	C31255	1	E91136	1	←	1	C61277	1	Piston	
13	2831041	1	2831042	1	←	1	2831043	1	Dust Seal	
14	2811071	1	2811086	1	←	1	2811087	1	U-Packing	
15	2833003	1	2833010	1	←	1	2833004	1	Buffer Seal	
16	2851038	2	←	2	←	2	2851043	2	O-Ring	
17	C31193	2	←	2	←	2	2710319	2	Adapter	
18	2715004	2	←	2	←	2	2715005	2	Union Cap	
19	C31171	1	E91107	1	←	1	C61112	1	Valve	
20	C31172	1	E91109	1	←	1	C61110	1	Valve Plug	
21	2851210	1	←	1	←	1	2851213	1	O-Ring	
22	2851207	1	←	1	←	1	←	1	O-Ring	
23	C31173	1	E91108	1	←	1	C61111	1	Valve Sleeve	
24	C31256	1	E91137	1	E91181	1	C61278	1	Front Head	
25	2700411	2	←	2	←	2	←	2	Grease Nipple	
26	C31226	2	E91119	2	←	2	C61252	2	Rod Pin	
27	C31127	2	E91121	2	C61169	2	←	2	Stop Pin	
28	C31246	2	D81151	2	←	2	←	2	Rubber Plug	
29	C31126	2	E91120	2	←	2	C61168	2	Front Head Pin	
30	SSC31225	1	SSE91111	1	←	1	SSC61241	1	Ring Bush	
31	SSC31440	1	SSE91212	1	←	1	SSC61412	1	Front Cover	
31 -1	SSC31185	1	SSE91122	1	←	1	SSC61213	1	Front Cover	Side Silence
31 -2	SSC31240	1	SSE91128	1	←	1	SSC61267	1	Front Cover	TR-F,TS-P
32	SSC31211	1	SSE91113	1	←	1	SSC61227	1	Rod(Moil Point)	
33	C31140	4	C61188	4	←	4	←	4	Washer	
34	C31271	4	E91152	4	←	4	C61294	4	Through Bolt	
35	C31272	4	E91153	4	←	4	C61295	4	Hex Nut	
36	C01162	1	←	1	←	1	←	1	Air Check Valve	
37	2851010	3	←	3	←	3	←	2	O-Ring	
38	-	-	-	-	-	-	-	-	O-Ring	Not Use
39	2702221	2	←	1	←	2	←	2	Hollow Hex Plug	
40	C31247	2	D81150	2	←	2	←	2	Rubber Plug	
41	-	-	-	-	-	-	-	-	Snap Ring	Not Use
42	C21173	2	←	2	←	2	←	2	Knock Pin	
43	Q11191	2	←	2	←	2	←	2	Hex Head Plug	
44	C31257	4	E91138	4	←	4	←	4	Round Nut	
45	2851010	1	(←)	(1)	←	2	2851014	1	O-Ring	

SB81A,100,100II,121

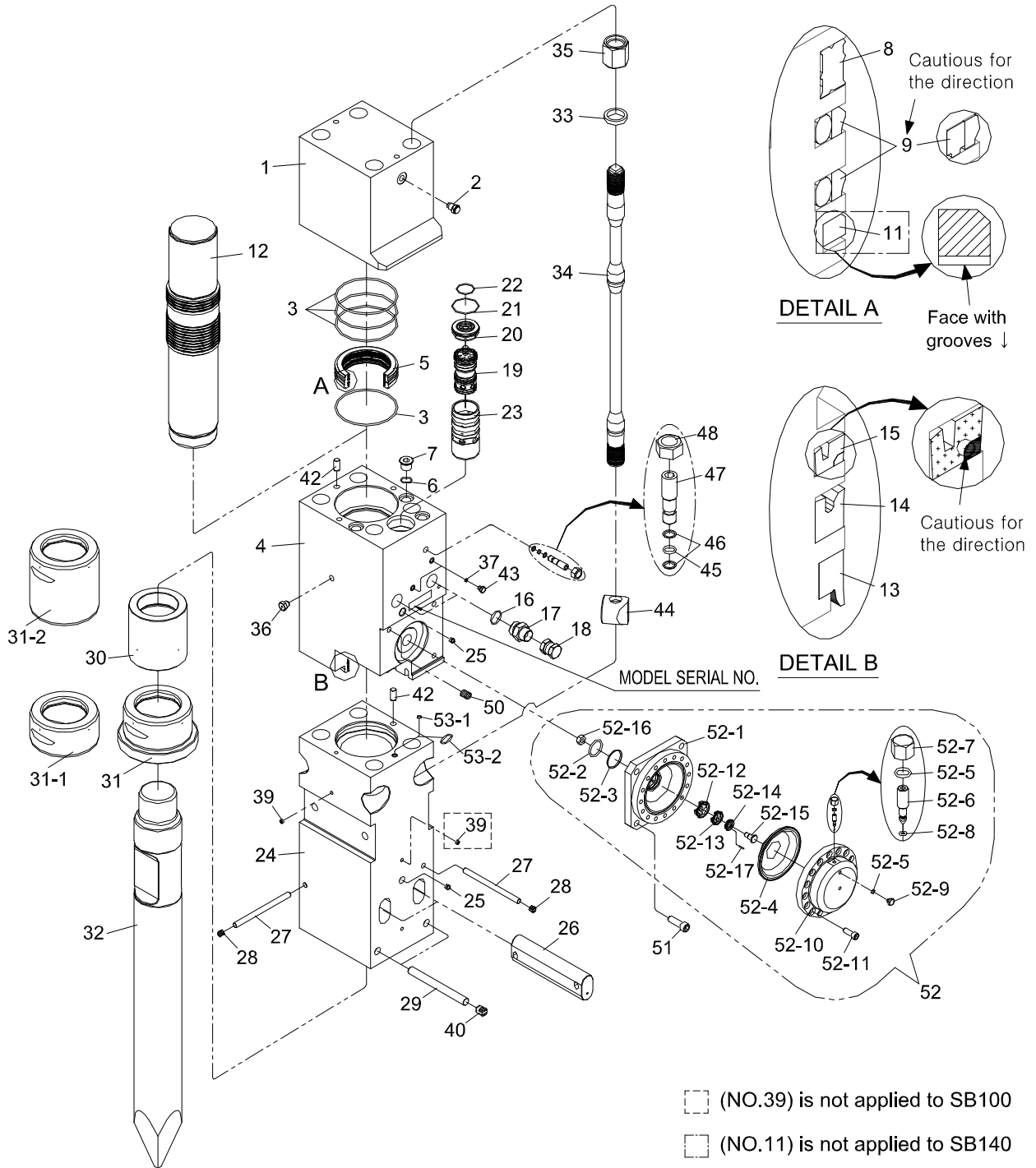

■ MAIN BODY (SB81A,100,100II,121)

NO	SB81A (#2993~)		SB100 (#261~)		SB100II (#2060~)		SB121 (#2321~)		PARTS NAME	REMARK
	P/N	Q'ty	P/N	Q'ty	P/N	Q'ty	P/N	Q'ty		
	C31 008	1Set	E91 002	1Set	E91 003	1Set	C61 006	1Set	Main Body Ass'y	
46	2841217	2	2841217	2	2841217	2	2841202	2	Back-Up Ring	
47	C31 210	1	C31 210	1	C31 210	1	C61 233	1	Valve Adjuster	
48	4101306	1	4101306	1	4101306	1	4101308	1	Nut	
49	-	-	-	-	-	-	-	-	Socket Plug	Not Use
50	4130039	4	4130039	4	4130039	4	4133025	4	Heli Sert Coil	
51	4011147	4	4011147	4	4011147	4	4011149	4	Socket Bolt	
52	C31 188	1	C31 188	1	C31 188	1	C61 137	1	Accumulator	
-1	C31 155	1	C31 155	1	C31 155	1	C61 138	1	Accumulator Body	
-2	2851051	1	2851051	1	2851051	1	2851051	1	O-Ring	
-3	2844901	1	2844901	1	2844901	1	2844901	1	Back-Up Ring	
-4	U81 253	1	U81 253	1	U81 253	1	C61 139	1	Diaphragm	
-5	2850014	2	2850014	2	2850014	2	2850014	2	O-Ring	
-6	U81 266	1	U81 266	1	U81 266	1	U81 266	1	Charging V/V	
-7	U81 275	1	U81 275	1	U81 275	1	U81 275	1	O-Ring Cap	
-8	2850003	1	2850003	1	2850003	1	2850003	1	O-Ring	
-9	U81 276	1	U81 276	1	U81 276	1	U81 276	1	O-Ring Plug	
-10	C31 154	1	C31 154	1	C31 154	1	C61 140	1	Accumulator Cover	
-11	4011366	12	4011366	12	4011366	16	4011108	16	Socket Bolt	
-12	C61 141	1	C61 141	1	C61 141	1	C61 141	1	Holder (A)	
-13	C61 142	1	C61 142	1	C61 142	1	C61 142	1	Holder (B)	
-14	C61 143	1	C61 143	1	C61 143	1	C61 143	1	Holder (C)	
-15	C61 144	1	C61 144	1	C61 144	1	C61 144	1	Holder Pin	
-16	U81 338	1	U81 338	1	U81 338	1	U81 338	1	Holder Nut	
-17	C61 145	1	C61 145	1	C61 145	1	C61 145	1	Center Pin	
53 -1	2851014	1	2851014	1	2851014	1	2851014	1	O-Ring	Old Main Body
-2	2851205	1	2851206	1	2851206	1	2851207	1	O-Ring	New Main Body

■ SB130,140,151

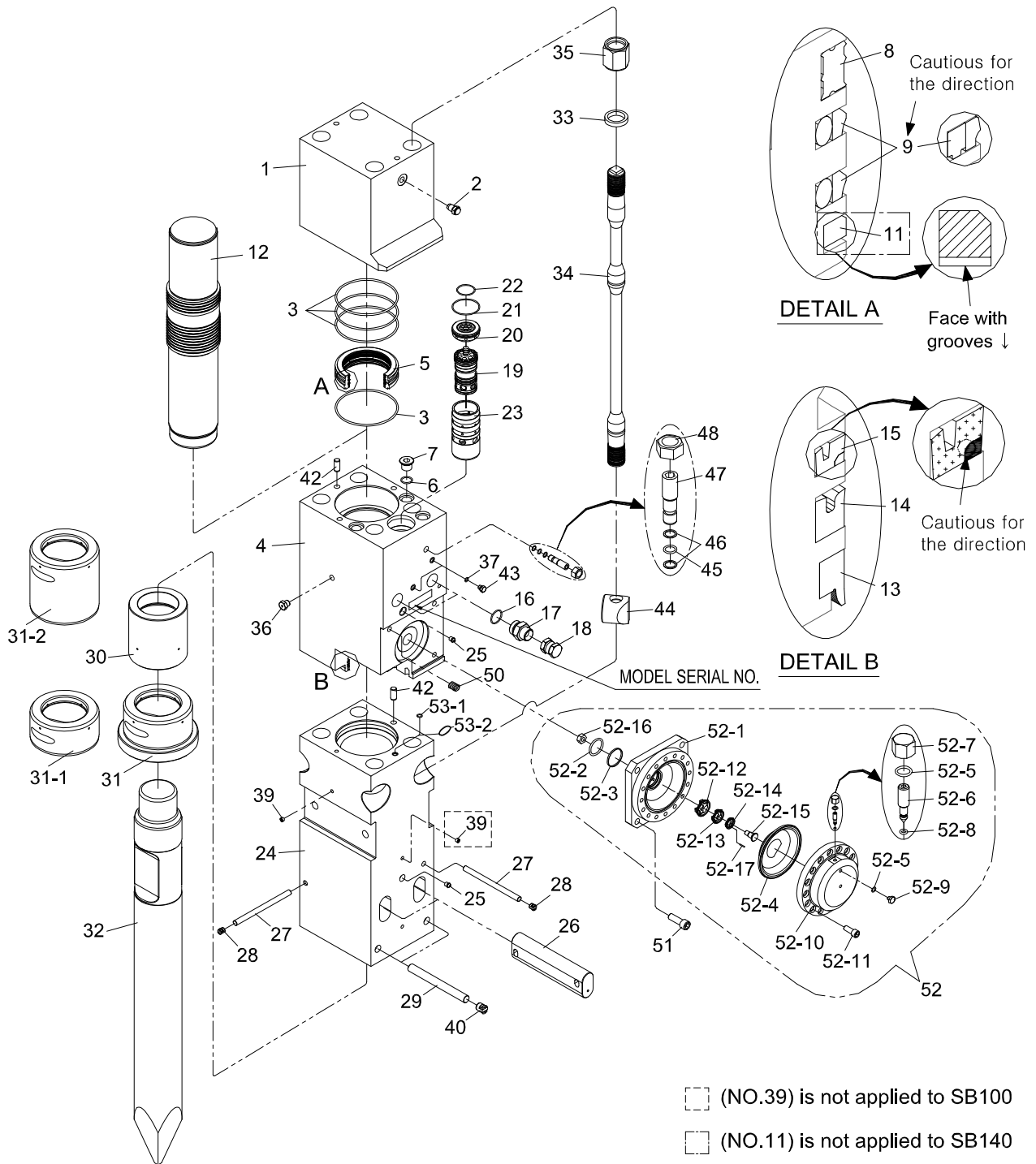

■ MAIN BODY (SB130,140,151)

NO	SB130 (#1385~)		SB140 (#137~)		SB151 (#236~)		PARTS NAME	REMARK
	P/N	Q'ty	P/N	Q'ty	P/N	Q'ty		
	D81005	1Set	L21002	1Set	C71002	1Set	Main Body Ass'y	
1	D81109	1	L21104	1	C71104	1	Back Head	
2	C51191	1	←	1	←	1	Charging Valve	
3	2851237	3	←	3	←	4	O-Ring	
4	D81101	1	L21101	1	C71153	1	Cylinder	
5	D81110	1	L21109	1	C71248	1	Seal Retainer	
6	2850033	3	←	3	2850035	3	O-Ring	
7	C61146	3	←	3	C71121	3	Socket Plug	
8	2835047	1	2835050	1	2835048	1	Gas Seal	
9	2811040	2	2811079	2	2811080	2	Step Seal	
10	-	-	-	-	-	-	O-Ring	Not Use
11	2819054	1	-	-	2819055	1	Buffer Seal	
12	D81174	1	L21119	1	C71199	1	Piston	
13	2831032	1	2831039	1	2831045	1	Dust Seal	
14	2811039	1	2811085	1	2811091	1	U-Packing	
15	2833020	1	2833021	1	2833017	1	Buffer Seal	
16	2851043	2	←	2	←	2	O-Ring	
17	2710319	2	←	2	←	2	Adapter	
18	2715005	2	←	2	←	2	Union Cap	
19	D81111	1	L21106	1	C71202	1	Valve	
20	D81112	1	L21108	1	C71204	1	Valve Plug	
21	2851212	1	2851215	1	2851216	1	O-Ring	
22	2851207	1	2851209	1	2851212	1	O-Ring	
23	D81113	1	L21107	1	C71203	1	Valve Sleeve	
24	D81177	1	L21111	1	C71200	1	Front Head	
25	2700411	2	←	2	←	2	Grease Nipple	
26	C61252	2	L21116	2	C71177	2	Rod Pin	
27	C61169	2	←	2	C61168	2	Stop Pin	
28	D81151	2	←	2	D81150	2	Rubber Plug	
29	C61168	2	←	2	C71120	2	Front Head Pin	
30	SSD81124	1	←	1	SSC71167	1	Ring Bush	
31	L21165	1	L21166	1	SSC71265	1	Front Cover	
31 -1	SSD81125	1	←	1	SSC71169	1	Front Cover	Side Silence
31 -2	SSD81147	1	←	1	SSC71188	1	Front Cover	TR-F,TS-P
32	SSD81115	1	←	1	SSC71157	1	Rod(Moil Point)	
33	C61188	4	C71128	4	←	4	Washer	
34	D81201	4	L21125	4	C71220	4	Through Bolt	
35	C61295	4	L21126	4	←	4	Hex Nut	
36	C01162	1	←	1	←	1	Air Check Valve	
37	2851010	2	←	2	←	2	O-Ring	
38	-	-	-	-	-	-	O-Ring	Not Use
39	2702221	2	←	2	←	2	Hollow Hex Plug	
40	D81150	2	←	2	C71194	2	Rubber Plug	
41	-	-	-	-	-	-	Snap Ring	Not Use
42	C21173	2	←	2	←	2	Knock Pin	
43	Q11191	2	←	2	←	2	Hex Head Plug	
44	E91138	4	C71201	4	←	4	Round Nut	
45 ★	2851014	2	2851015	1	←	1	O-Ring	

SB130,140,151

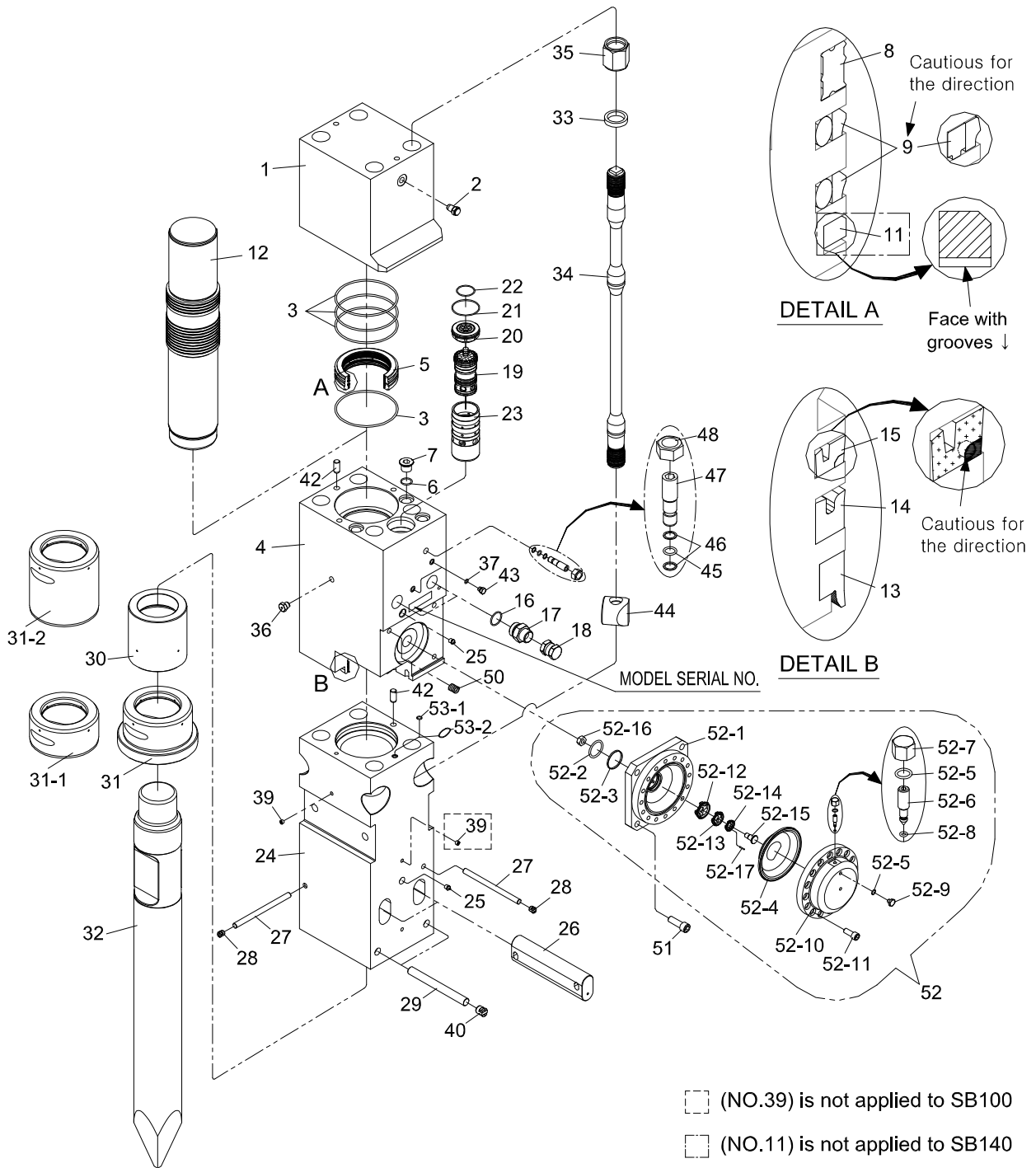

■ MAIN BODY (SB130,140,151)

NO	SB130 (#1385~)		SB140 (#137~)		SB151 (#236~)		PARTS NAME	REMARK
	P/N	Q'ty	P/N	Q'ty	P/N	Q'ty		
	D81 005	1Set	L21 002	1Set	C71 002	1Set	Main Body Ass'y	
46	2841202	2	2841216	2	2841216	2	Back-Up Ring	
47	C61 233	1	C71 162	1	C71 162	1	Valve Adjuster	
48	4101308	1	4101309	1	4101309	1	Nut	
49	-	-	-	-	-	-	Socket Plug	Not Use
50	4133025	4	4133025	4	4130041	4	Heli Sert Coil	
51	4011149	4	4011149	4	4011186	4	Socket Bolt	
52	C61 137	1	C61 137	1	C71 110	1	Accumulator	
-1	C61 138	1	C61 138	1	C71 111	1	Accumulator Body	
-2	2851051	1	2851051	1	2851212	1	O-Ring	
-3	2844901	1	2844901	1	2844003	1	Back-Up Ring	
-4	C61 139	1	C61 139	1	C71 113	1	Diaphragm	
-5	2850014	2	2850014	2	2850014	2	O-Ring	
-6	U81 266	1	U81 266	1	U81 266	1	Charging V/V	
-7	U81 275	1	U81 275	1	U81 275	1	O-Ring Cap	
-8	2850003	1	2850003	1	2850003	1	O-Ring	
-9	U81 276	1	U81 276	1	U81 276	1	O-Ring Plug	
-10	C61 140	1	C61 140	1	C71 112	1	Accumulator Cover	
-11	4011108	16	4011108	16	4011147	16	Socket Bolt	
-12	C61 141	1	C61 141	1	C71 115	1	Holder (A)	
-13	C61 142	1	C61 142	1	C71 116	1	Holder (B)	
-14	C61 143	1	C61 143	1	C71 117	1	Holder (C)	
-15	C61 144	1	C61 144	1	C71 118	1	Holder Pin	
-16	U81 338	1	U81 338	1	U81 338	1	Holder Nut	
-17	C61 145	1	C61 145	1	C71 114	1	Center Pin	
53	-1 2851014	1	2851014	1	2851014	1	O-Ring	Old Main Body
-2	2851207	1	2851207	1	2851207	2	O-Ring	New Main Body

SB147P,147,157,160

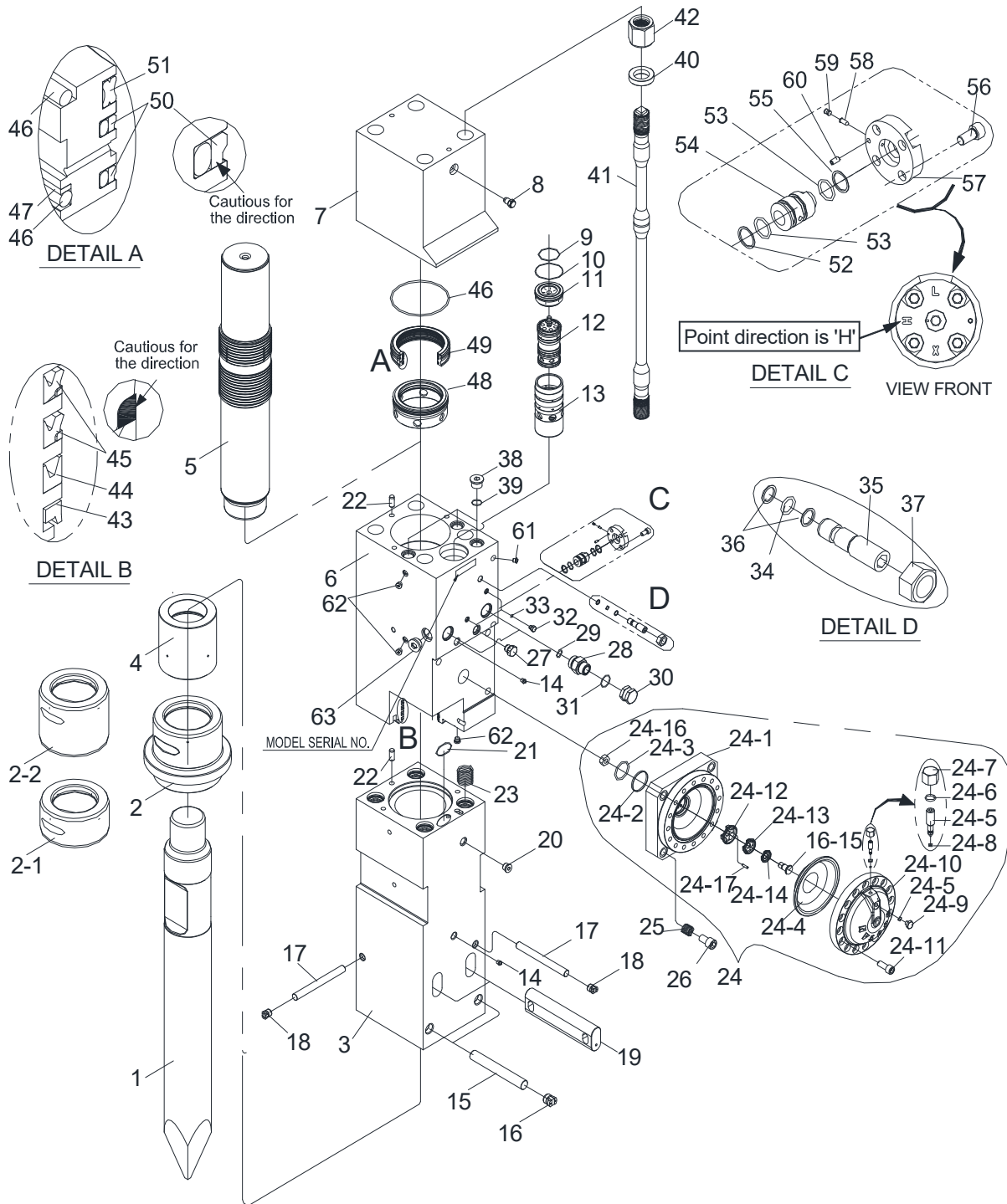

■ SB147P,147,157,160 MAIN BODY

NO	SB147P (#011~)		SB147 (#011~)		SB157 (#011~)		SB160 (#011~)		PARTS NAME	REMARK
	P/N	Q'ty	P/N	Q'ty	P/N	Q'ty	P/N	Q'ty		
	T41001	1Set	T51001	1Set	T71001	1Set	T61001	1Set	Main Body Ass' y	
1	SSC61293	1	SSD81115	1	SSC71157	1	SST61108	1	Rod	Mail Port Type-Long Side Type Silence Side Type TR-F, TS-P Type
2	SSC61412	1	L21166	1	SSC71265	1	SST61110	1	Front Cover	
-1	SSC61213	1	SSD81125	1	SSC71169	1	T61124	1	Front Cover	
-2	SSC61267	1	SSD81147	1	SSC71188	1	-	1	Front Cover	
3	T41103	1	T51103	1	T71101	1	T71101	1	Front Head	
4	SST41106	1	SSD81124	1	SST71115	1	SST61114	1	Ring Bush	
5	T41104	1	T51104	1	T71104	1	T61103	1	Piston	
6	T41102	1	T51102	1	T71103	1	T61102	1	Cylinder	
7	L21104	1	-	1	C71104	1	-	1	Back Head	
8	C51191	1	-	1	-	1	-	1	Charging Valve	
9	2851209	1	-	1	2851212	1	-	1	O-Ring	
10	2851215	1	-	1	2851216	1	-	1	O-Ring	
11	L21108	1	-	1	C71204	1	-	1	Valve Plug	
12	L21106	1	-	1	C71202	1	-	1	Valve	
13	L21107	1	-	1	C71203	1	-	1	Valve Sleeve	
14	2700411	2	-	2	-	2	-	2	Grease Nipple	
15	C61168	2	-	2	C71120	2	-	2	Front Head Pin	
16	D81150	2	-	2	C71194	2	-	2	Rubber Plug	
17	C61169	2	-	2	C71140	2	-	2	Stop Pin	
18	D81151	2	-	2	D81150	2	-	2	Rubber Plug	
19	L21116	2	-	2	C71177	2	-	2	Rod Pin	
20	N57103	1	-	2	-	1	-	1	Blank Plug	
21	-	-	2851014	1	2851206	1	-	1	O-Ring	
22	C21173	2	-	2	-	2	-	2	Knock Pin	
23	Q01115	4	-	4	-	4	-	4	Helisert Coil	
24	C61448	1	-	1	C71434	1	-	1	Accumulator Ass' y	
-1	C61449	1	-	1	C71435	1	-	1	Accumulator Body	
-2	2851063	1	-	1	-	1	-	1	O-Ring	
-3	2841008	1	-	1	-	1	-	1	Back-Up Ring	
-4	C61440	1	-	1	C71425	1	-	1	Diaphragm	'13,11~'19,06
-4	C61440	1	-	1	C71408	1	-	1	Diaphragm	'19,06~
-5	U81266	1	-	1	-	1	-	1	Charging Valve	
-6	2850014	2	-	2	-	2	-	2	O-Ring	
-7	U81275	1	-	1	-	1	-	1	O-Ring Cap	
-8	2850003	1	-	1	-	1	-	1	O-Ring	
-9	U81276	1	-	1	-	1	-	1	O-Ring Plug	
-10	C71112	1	-	1	C71406	1	-	1	Accumulator Cover	
-11	4011147	16	-	16	-	16	-	16	Socket Bolt	
-12	C71115	1	-	1	-	1	-	1	Holder (A)	
-13	C71116	1	-	1	-	1	-	1	Holder (B)	
-14	C71117	1	-	1	-	1	-	1	Holder (C)	
-15	C71118	1	-	1	-	1	-	1	Holder Pin	
-16	U81338	1	-	1	-	1	-	1	Holder Nut	
-17	C71114	1	-	1	-	1	-	1	Center Pin	
25	4130041	4	-	4	4131043	4	-	4	Helisert Coil	

SB147P,147,157,160

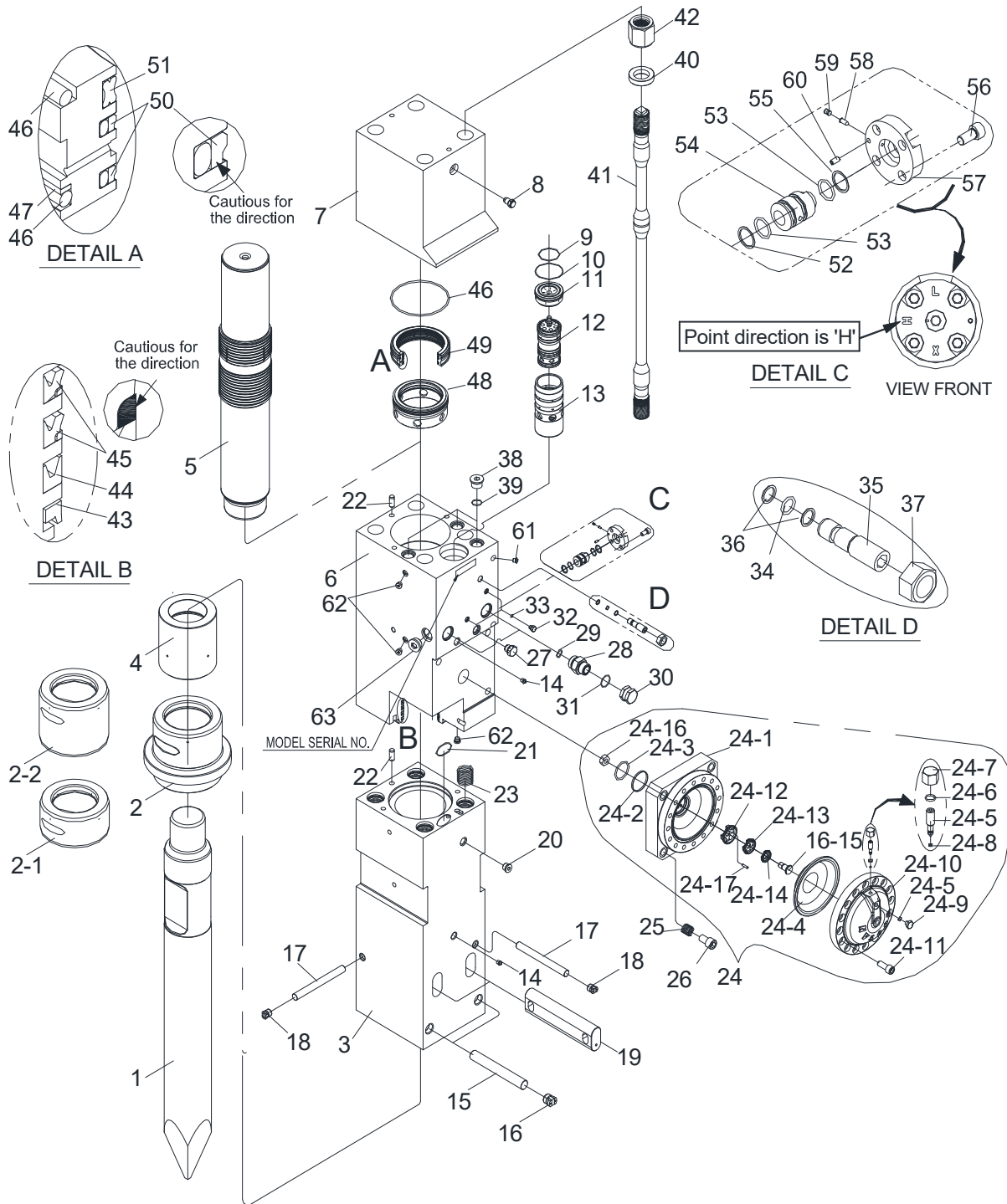

■ SB147P,147,157,160 MAIN BODY

NO	SB147P (#011~)		SB147 (#011~)		SB157 (#011~)		SB160 (#011~)		PARTS NAME	REMARK
	P/N	Q'ty	P/N	Q'ty	P/N	Q'ty	P/N	Q'ty		
	T41 001	1Set	T51 001	1Set	T71 001	1Set	T61 001	1Set	Main Body Ass' y	
26	4011186	4	4011186	4	4013227	4	4013227	4	Socket Bolt	
27	C71 277	1	C71 277	1	C71 277	1	C71 277	1	Air Check Valve	
28	C61 348	2	C61 348	2	C61 348	2	C61 348	2	Adapter	
29	2851043	2	2851043	2	2851043	2	2851043	2	O-Ring	
30	2715064	2	2715064	2	2715064	2	2715064	2	Union Cap	
31	2851202	2	2851202	2	2851202	2	2851202	2	O-Ring	
32	Q11 191	2	Q11 191	2	Q11 191	2	Q11 191	2	Hex Head Plug	
33	2851010	2	2851010	2	2851010	2	2851010	2	O-Ring	
34	2851015	1	2851015	1	2851015	1	2851015	1	O-Ring	
35	C71 162	1	C71 162	1	C71 162	1	C71 162	1	Valve Adjuster	
36	2841216	2	2841216	2	2841216	2	2841216	2	Back-Up Ring	
37	4101309	1	4101309	1	4101309	1	4101309	1	Hex Nut	
38	C61 146	3	C61 146	3	C71 121	3	C71 121	3	Socket Plug	
39	2850033	3	2850033	3	2850035	3	2850035	3	O-Ring	
40	C71 128	4	C71 128	4	C71 128	4	C71 128	4	Washer	
41	T41 113	4	T51 108	4	T71 109	4	T71 109	4	Through Bolt	
42	C71 259	4	C71 259	4	C71 259	4	C71 259	4	Hex Nut	
43	2831931	1	2831932	1	2831931	1	2831933	1	Dust Seal	
44	2819111	1	2819112	1	2819111	1	2819113	1	U-Packing	
45	2819107	2	2819108	2	2819107	2	2819109	2	U-Packing	
46	2851237	3	2851237	3	2851237	3	2851237	3	O-Ring	
47	2843047	1	2843047	1	2843047	1	2843047	1	Back-Up Ring	
48	T41 109	1	T51 105	1	T71 105	1	T61 104	1	Upper Brass Retainer	
49	T41 112	1	T51 107	1	T71 108	1	T61 107	1	Upper Seal Retainer	
50	2811124	2	2811079	2	2811080	2	2811123	2	Step Seal	
51	2835063	1	2835050	1	2835048	1	2835057	1	Gas Seal	
52	2842331	1	2842331	1	2842331	1	2842331	1	Back-Up Ring	
53	2851201	2	2851201	2	2851201	2	2851201	2	O-Ring	
54	C71 309	1	C71 309	1	C71 309	1	C71 309	1	Select Valve	
55	2842201	1	2842201	1	2842201	1	2842201	1	Back-Up Ring	
56	4011058	4	4011058	4	4011058	4	4011058	4	Socket Bolt	
57	Q31 110	1	Q31 110	1	Q31 110	1	Q31 110	1	Valve Cover	
58	Q31 112	1	Q31 112	1	Q31 112	1	Q31 112	1	Select Pin	
59	Q31 113	1	Q31 113	1	Q31 113	1	Q31 113	1	Rubber Spring	
60	4300080	1	4300080	1	4300080	1	4300080	1	Spring Pin	
61	N57 100	10	N57 100	11	N57 100	6	N57 100	6	Blank Plug	
62	N57 101	1	-	-	N57 101	5	N57 101	5	Blank Plug	
63	C71 258	1	C71 258	1	C71 258	1	C71 258	1	Blank Plug	

■ SB177 MAIN BODY

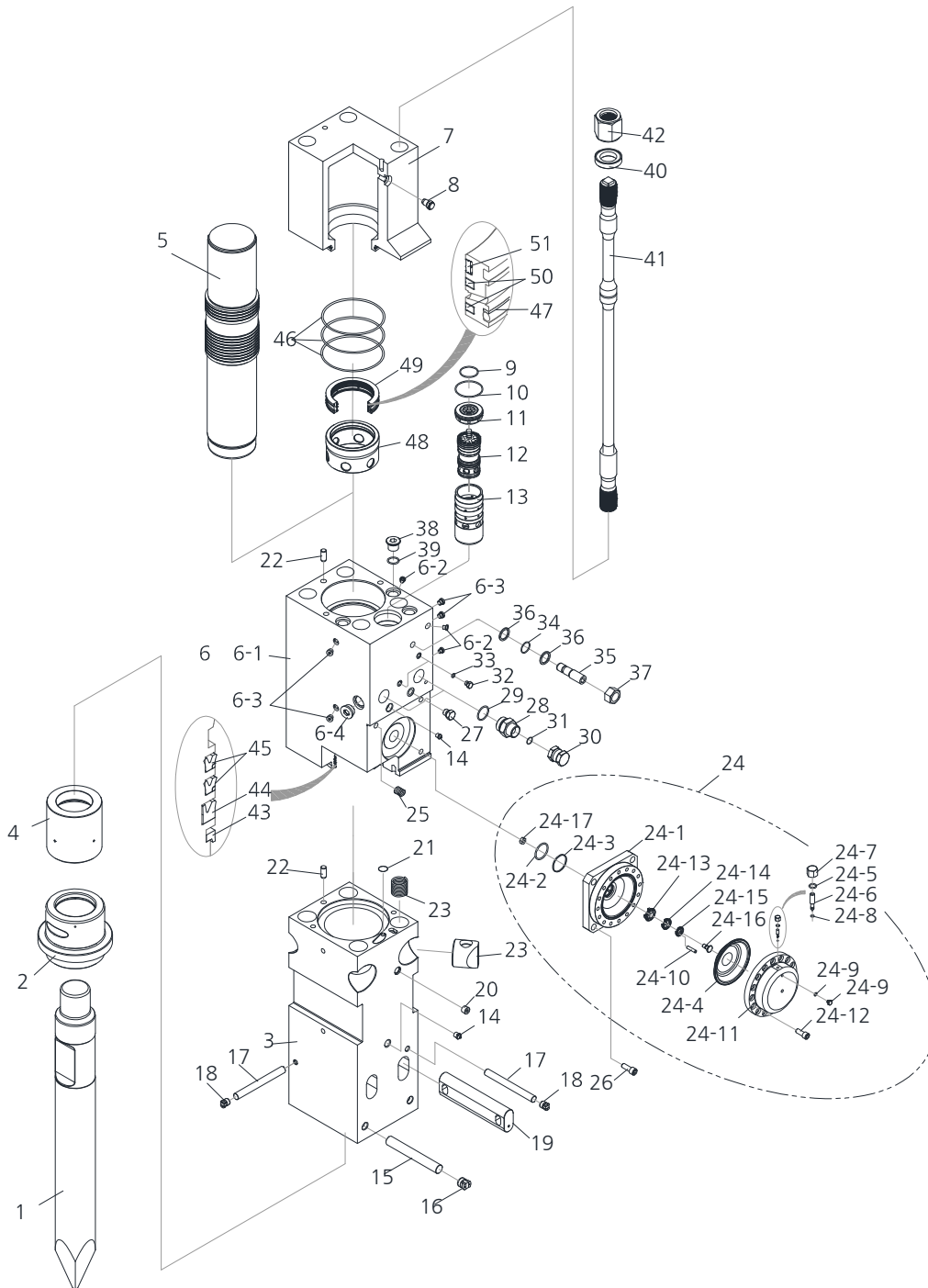

■ SB177 MAIN BODY

NO	SB177		PARTS NAME	REMARK
	P/N	Q'ty		
	B0006312	1Set	Main Body Ass' y	
1	SSB0001324	1	Rod	Moil Pont Type-Long
2	SSB0006348	1	Front Cover	Side Type
3	B0001317	1	Front Head	
4	SSB0001320	1	Ring Bush	
5	B0006165	1	Piston	
6	B0006313	1	Cylinder	
7	B0006315	1	Back Head	
8	C51191	1	Charging Valve	
9	2851212	1	O-Ring	
10	2851216	1	O-Ring	
11	C71204	1	Valve Plug	
12	C71202	1	Valve	
13	C71203	1	Valve Sleeve	
14	2700411	2	Grease Nipple	
15	C71120	2	Front Head Pin	
16	C71194	2	Rubber Plug	
17	B0001416	2	Stop Pin	
18	D81150	2	Rubber Plug	
19	B0001318	2	Rod Pin	
20	N57103	1	Blank Plug	
21	2851207	1	O-Ring	
22	C21173	2	Knock Pin	
23	C71201	4	Round Nut	
24	B0001348	1	Accumulator Ass' y	
	-1	B0001368	1	Accumulator Body
	-2	2851063	1	O-Ring, 1B P75
	-3	2841008	1	Back-Up Ring
	-4	C71425	1	Diaphragm
	-5	2850014	1	O-Ring, 1A P14
	-6	U81266	1	Charging Valve
	-7	U81275	2	O-Ring Cap
	-8	2850003	1	O-Ring,1A P5
	-9	U81276	1	O-Ring Plug
	-10	C71114	1	Center Pin
	-11	C71406	1	Accumulator Cover
	-12	4011147	16	Bolt,Socket,M20X2,5X50
	-13	C71115	1	Holder-A
	-14	C71116	1	Holder-B
	-15	C71117	1	Holder-C
	-16	C71118	1	Holder Pin
	-17	U81338	1	Holder Nut
25	4131043	4	Helisert Coil	

SB177 MAIN BODY

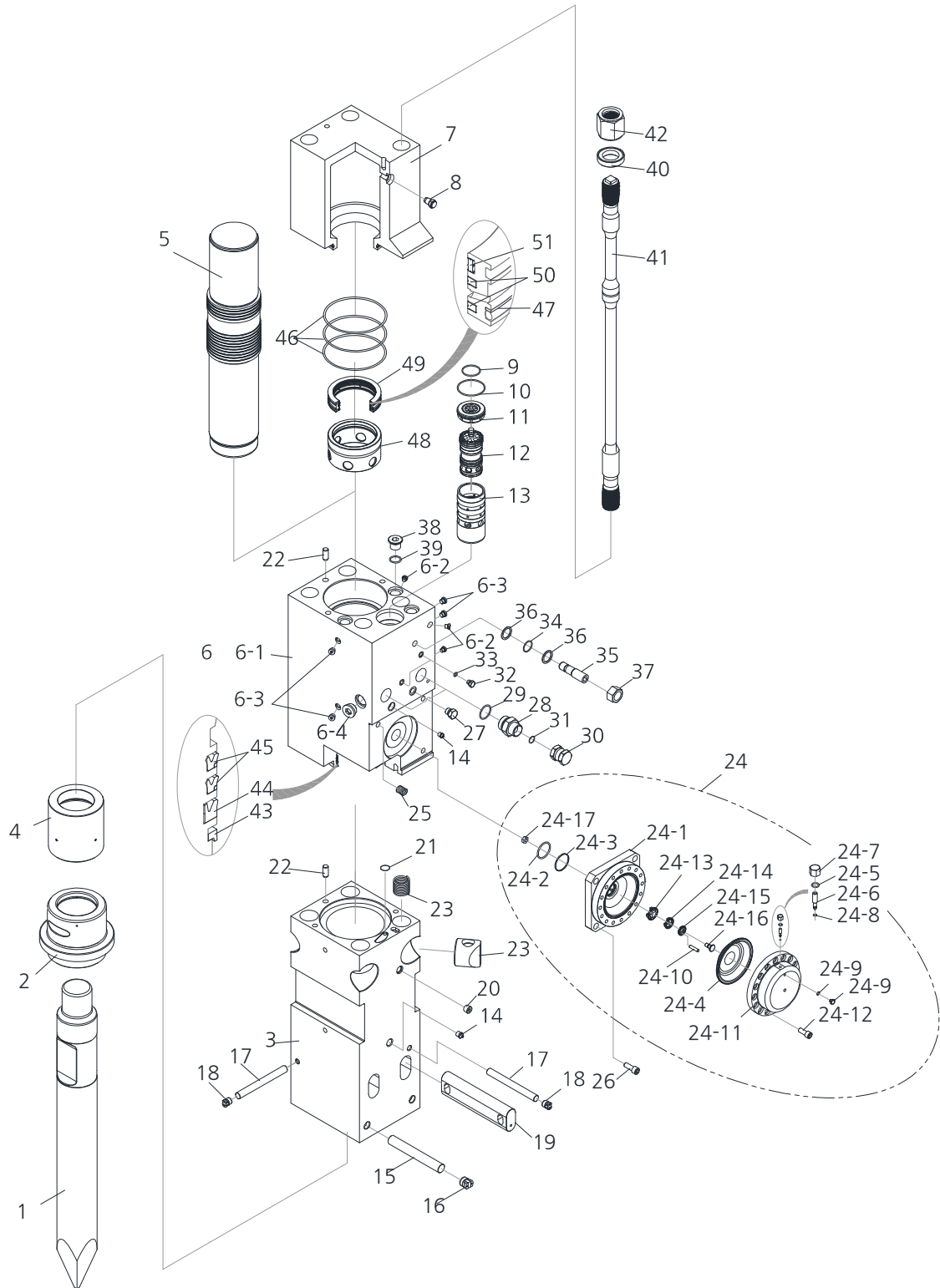

■ SB177 MAIN BODY

NO	SB177		PARTS NAME	REMARK
	P/N	Q'ty		
	B0006312	1Set	Main Body Ass' y	
26	4013227	4	Socket Bolt	
27	C71277	1	Valve,Air Check	
28	C61348	2	Adapter	
29	2851043	2	O-Ring	
30	2715064	2	Cap,Union	
31	2851202	2	O-Ring	
32	Q11191	2	Plug,Hex Head	
33	2851010	2	O-Ring	
34	2851019	1	O-Ring	
35	B0004790	1	Valve,Adjuster	
36	-	-	Ring,Back Up	
37	B0004990	1	Nut,Hex	
38	C71121	3	Plug,Socket	
39	2850035	3	O-Ring	
40	C71128	4	Washer	
41	B0001956	4	Through Bolt	
42	L21126	4	Nut,Hex	
43	B0005749	1	Seal,Dust	
44	B0005750	1	Packing,U	
45	B0005751	2	Packing,U	
46	B0005752	3	O-Ring	
47	B0005753	1	Ring,Back Up	
48	B0005745	1	Upper Brass Retainer	
49	B0005748	1	Retainer,Seal	
50	2811145	2	Seal,Step	
51	2835066	1	Seal,Gas	

02. Seal kit

■ SEAL KIT (SB10 II ~ SB50)

NO	PARTS NAME	SB10 II		SB20 II		SB30 II		SB35 II		SB40 II		SB43 II		SB45		SB50	
		P/ N	Q'ty	P/ N	Q'ty	P/ N	Q'ty	P/ N	Q'ty	P/ N	Q'ty	P/ N	Q'ty	P/ N	Q'ty	P/ N	Q'ty
	Seal Kit	E8X 001	1	FOX 001	1	E7X 001	1	F8X 001	1	COX 001	1	F9X 001	1	D4X 001	1	C1X 001	1
3	O-Ring	2851208	3	2851209	3	2851210	3	2851214	3	2856012	3	2851216	3	2851219	3	2851223	3
6	O-Ring	2850010	3	2850010	3	2850010	3	2850014	3	2850016	3	2850016	3	2850017	3	2850020	4
8	Gas Seal	2835035	1	2835036	1	2835037	1	2835038	1	2835039	1	2835040	1	2835041	1	2835042	1
9	Step Seal U-Packing	2811044	2	2811017	2	2811018	2	2811045	2	2811046	2	2811047	2	2811048	2	2811067	2
11	Buffer Seal	2819063	1	2819061	1	2819059	1	-	-	-	-	-	-	-	-	-	-
13	Dust Seal	2831057	1	2831058	1	2831013	1	2831063	1	2831022	1	2831017	1	2831068	1	2831023	1
14	U-Packing	2811055	1	2811056	1	2811010	1	2811060	1	2811031	1	2811009	1	2811064	1	2811032	1
15	Buffer Seal	2819062	1	2819060	1	2819058	1	2833011	1	2819056	1	2833012	1	2833001	1	2833015	1
16	O-Ring	2851018	2	2851018	2	2851018	2	2851018	2	2851018	2	2851018	2	2851022	2	2851022	2
21	O-Ring	2851030	1	2851030	1	2851033	1	2851033	1	2851040	1	2851204	1	2851205	1	2851051	1
22	O-Ring	2851201	1	2851201	1	2851201	1	2851201	1	2851201	1	2851201	1	2851202	1	2851203	1
52	Seal Packing	Z004088	1	Z004088	1	Z004088	1	Z004088	1	Z004088	1	Z004088	1	Z004088	1	Z004089	1

■ SEAL KIT (SB60 ~ SB151) - For Steel Seal-Retainer

NO	PARTS NAME	SB60		SB70 SB81NII		SB81		SB81A		SB100 SB100II		SB121		SB130		SB140		SB151	
		P/ N	Q'ty	P/ N	Q'ty	P/ N	Q'ty	P/ N	Q'ty	P/ N	Q'ty	P/ N	Q'ty	P/ N	Q'ty	P/ N	Q'ty	P/ N	Q'ty
	Seal Kit	C2X 001	1	L0X 003	1	C3X 005	1	C3X 006	1	E9X 003	1	C6X 003	1	D8X 004	1	L2X 003	1	C7X 003	1
3	O-Ring	2851226	3	2851229	3	2851232	3	-	3	2851234	3	2851235	4	2851237	3	-	3	-	4
6	O-Ring	2850021	3	-	3	2850024	3	-	3	-	3	2850033	3	-	3	-	3	2850035	3
8	Gas Seal	2835043	1	2835034	1	2835044	1	-	1	2835045	1	2835046	1	2835047	1	2835050	1	2835048	1
9	Step Seal	2811049	2	2811066	2	2811076	2	-	2	2811077	2	2811078	2	2811040	2	2811079	2	2811080	2
11	Buffer Seal	-	-	-	-	2819051	1	-	1	2819052	1	2819053	1	2819054	1	-	-	2819055	1
13	Dust Seal	2831073	1	2831040	1	2831041	1	-	1	2831042	1	2831043	1	2831044	1	2831039	1	2831045	1
14	U-Packing	2811007	1	2811089	1	2811090	1	-	1	2811086	1	2811087	1	2811088	1	2811085	1	2811091	1
15	Buffer Seal	2833019	1	2833013	1	2833003	1	-	1	2833010	1	2833004	1	2833020	1	2833021	1	2833017	1
16	O-Ring	2851028	2	-	2	2851038	2	-	2	-	2	2851043	2	-	2	-	2	-	2
21	O-Ring	2851208	1	2851209	1	2851210	1	-	1	-	1	2851213	1	2851212	1	2851215	1	2851216	1
22	O-Ring	2851205	1	2851206	1	2851207	1	-	1	-	1	-	1	-	1	2851209	1	2851212	1
37	O-Ring	2851201	1	-	3	2851010	3	-	2	-	2	2851030	2	-	2	-	2	-	2
45	Seal packing	Z004090	1	-	1	Z004091	1	-	1	-	1	-	1	-	1	-	1	Z004092	1
46	Back-Up Ring	2841218	2	2841217	2	-	2	-	2	-	2	2841202	2	-	2	2841216	2	-	2
52	O-Ring	2851014	1	-	1	-	1	-	2	-	3	-	4	-	3	-	4	-	2
52-2	O-Ring	2851204	-	-	-	-	-	2851051	1	-	1	-	1	-	1	-	1	2851212	1
52-3	Back-Up Ring	-	-	-	-	-	-	2844901	1	-	1	-	1	-	1	-	1	2844003	1
52-5	O-Ring	-	-	2851010	1	-	-	-	1	-	1	-	-	-	-	2850015	1	2850015	1
52-8	O-Ring	-	-	-	-	-	-	2850003	1	-	1	-	1	-	1	-	1	-	1
53	O-Ring	-	-	2851014	1	-	1	-	1	-	1	-	1	-	1	-	-	-	1
54	O-Ring	2850007	1	2850017	2	-	2	-	2	-	2	-	2	-	2	-	-	-	2

■ SEAL KIT (SB43B) - For Steel Seal-Retainer

NO	PARTS NAME	SB43B		REMARK
		P/ N	Q'ty	
	Seal Kit	F9X 002	1 SET	
3	O-Ring	2851216	3	
6	O-Ring	2850016	3	
8	Gas Seal	2835040	1	
9	Step Seal	2811047	2	
11	Dust Seal	2831017	1	
12	U-Packing	2811009	1	
13	Buffer Seal	2833012	1	
14	O-Ring	2851022	2	
19	O-Ring	2851208	1	
20	O-Ring	2851205	1	
38 -2	O-Ring	2851051	1	
38 -3	Back-Up Ring	2844901	1	
38 -7	O-Ring	2850014	2	
38 -10	O-Ring	2850003	1	
39	O-Ring	2850017	1	

■ SEAL KIT (SB177)

NO	PARTS NAME	SB177		REMARK
		P/ N	Q'ty	
	Seal Kit	B0005756	1Set	
1	U-Packing	B0005751	2	
2	Dust Seal	B0005749	1	
3	U-Packing	B0005750	1	
4	Step Seal	2811145	2	
5	Gas Seal	2835066	1	
6	Back Up Ring	B0005753	1	
7	Back Up Ring	2841008	1	
8	O-Ring	2851212	1	
9	O-Ring	2851216	1	
10	O-Ring	2851207	1	
11	O-Ring	2851043	2	
12	O-Ring	2851202	2	
13	O-Ring	2851010	2	
14	O-Ring	2851019	1	
15	O-Ring	2850035	3	
16	O-Ring	B0005752	3	
17	O-Ring	2850014	2	
18	O-Ring	2850003	1	
19	Back Up Ring	-	-	

■ SEAL KIT (SB147P,147,157,160)

NO	PARTS NAME	SB147P		SB147		SB157		SB160		REMARK
		P/ N	Q'ty	P/ N	Q'ty	P/ N	Q'ty	P/ N	Q'ty	
	Seal Kit	T41 114	1Set	T51 115	1Set	T71 118	1Set	T61 118	1Set	
1	O-Ring		1	2851209	1	2851212	1	←	1	
2	O-Ring		1	2851215	1	2851216	1	←	1	
3	O-Ring	-	-	2851014	1	2851206	1	←	1	
4	O-Ring		1	2851063	1	←	1	←	1	
5	Back-Up Ring		1	2841008	1	←	1	←	1	
6	O-Ring		2	2851043	2	←	2	←	2	
7	O-Ring		2	2851202	2	←	2	←	2	
8	O-Ring		2	2851010	2	←	2	←	2	
9	O-Ring		1	2851015	1	←	1	←	1	
10	Back-Up Ring		2	2841216	2	←	2	←	2	
11	O-Ring		3	2850033	3	2850035	3	←	3	
12	Dust Seal	2831931	1	2831932	1	2831931	1	2831933	1	
13	U-Packing	2819111	1	2819112	1	2819111	1	2819113	1	
14	U-Packing	2819107	2	2819108	2	2819107	2	2819109	2	
15	O-Ring		3	2851237	3	←	3	←	3	
16	Back-Up Ring		1	2843047	1	←	1	←	1	
17	Step Seal	2811124	2	2811079	2	2811080	2	2811123	2	
18	Gas Seal	2835063	1	2835050	1	2835048	1	2835057	1	
19	Back-Up Ring		1	2842331	1	←	1	←	1	
20	O-Ring		2	2851201	2	←	2	←	2	
21	Back-Up Ring		1	2842201	1	←	1	←	1	

03. Cylinder Set

■ Cylinder Set (SB147P/773kg)

NO	PARTS NAME	P/N	Q'ty	REMARK
	Cylinder Set	T41 115	1SET	
5	Piston	T41 104	1	
6	Cylinder	T40 102	1	
9	O-Ring	2851209	1	
10	O-Ring	2851215	1	
11	Valve Plug	L21 108	1	
12	Valve	L21 106	1	
13	Valve Sleeve	L21 107	1	
14	Grease Nipple	2700411	1	
24	Accumulator ass'y	C61 448	1	
25	Helisert Coil	4130041	4	
26	Socket Bolt	4011186	4	
27	Air Check Valve	C71 277	1	
28	Adapter	C61 348	2	
29	O-Ring	2851043	2	
30	Union Cap	2715064	2	
31	O-Ring	2851202	2	
32	Hex Head Plug	Q11 191	2	
33	O-Ring	2851010	2	
34	O-Ring	2851015	1	
35	Valve Adjuster	C71 162	1	
36	Back-Up Ring	2841216	2	
37	Hex Nut	4100309	1	
38	Socket Plug	C61 146	3	
39	O-Ring	2850033	3	
43	Dust Seal	2831931	1	
44	U-Packing	2819111	1	
45	U-Packing	2819107	2	
46	O-Ring	2851237	2	
47	Back-Up Ring	2843047	1	
48	Upper Brass Retainer	T41 109	1	
49	Upper Seal Retainer	T41 112	1	
51	Gas Seal	2835063	1	
52	Back-Up Ring	2842331	1	
53	O-Ring	2851201	2	
54	Select Valve	C71 309	1	
55	Back-Up Ring	2842201	1	
56	Socket Bolt	4011058	4	
57	Adjuster Cover	Q31 110	1	
58	Select Pin	Q31 112	1	
59	Rubber Spring	Q31 113	1	
60	Spring Pin	4300080	1	
61	Blanking Plug	N57 100	10	
62	Blanking Plug	N57 101	1	
63	Blanking Plug	C71 258	1	



■ Cylinder Set (SB147/728kg)

NO	PARTS NAME	P/N	Q' ty	REMARK
	Cylinder Set	T51 116	1SET	
5	Piston	T51 104	1	
6	Cylinder	T51 102	1	
9	O-Ring	2851209	1	
10	O-Ring	2851215	1	
11	Valve Plug	L21 108	1	
12	Valve	L21 106	1	
13	Valve Sleeve	L21 107	1	
14	Grease Nipple	2700411	1	
24	Accumulator ass' y	C61 448	1	
25	Helisert Coil	4130041	4	
26	Socket Bolt	4011186	4	
27	Air Check Valve	C71 277	1	
28	Adapter	C61 348	2	
29	O-Ring	2851043	2	
30	Union Cap	2715064	2	
31	O-Ring	2851202	2	
32	Hex Head Plug	Q11 191	2	
33	O-Ring	2851010	2	
34	O-Ring	2851015	1	
35	Valve Adjuster	C71 162	1	
36	Back-Up Ring	2841216	2	
37	Hex Nut	4100309	1	
38	Socket Plug	C61 146	3	
39	O-Ring	2850033	3	
43	Dust Seal	2831931	4	
44	U-Packing	2819111	4	
45	U-Packing	2819107	4	
46	O-Ring	2851237	1	
47	Back-Up Ring	2843047	1	
48	Upper Brass Retainer	T41 109	2	
49	Upper Seal Retainer	T41 112	1	
50	Step Seal	2811124	1	
51	Gas Seal	2835063	1	
52	Back-Up Ring	2842331	2	
53	O-Ring	2851201	1	
54	Select Valve	C71 309	1	
55	Back-Up Ring	2842201	2	
56	Socket Bolt	4011058	1	
57	Adjuster Cover	Q31 110	1	
58	Select Pin	Q31 112	1	
59	Rubber Spring	Q31 113	1	
60	Spring Pin	4300080	1	
61	Blanking Plug	N57 100	11	
63	Blanking Plug	C71 258	1	

■ Cylinder Set (SB157/917kg)

NO	PARTS NAME	P/N	Q' ty	REMARK
	Cylinder Set	T71 119	1SET	
5	Piston	T71 104	1	
6	Cylinder	T71 103	1	
9	O-Ring	2851212	1	
10	O-Ring	2851216	1	
11	Valve Plug	C71 204	1	
12	Valve	C71 202	1	
13	Valve Sleeve	C71 203	1	
14	Grease Nipple	2700411	1	
24	Accumulator ass' y	C71 434	1	
25	Helisert Coil	4131043	4	
26	Socket Bolt	4013227	4	
27	Air Check Valve	C71 277	1	
28	Adapter	C61 348	2	
29	O-Ring	2851043	2	
30	Union Cap	2715064	2	
31	O-Ring	2851202	2	
32	Hex Head Plug	Q11 191	2	
33	O-Ring	2851010	2	
34	O-Ring	2851015	1	
35	Valve Adjuster	C71 162	1	
36	Back-Up Ring	2841216	2	
37	Hex Nut	4101309	1	
38	Socket Plug	C71 121	3	
39	O-Ring	2850035	3	
43	Dust Seal	2831931	1	
44	U-Packing	2819111	1	
45	U-Packing	2819107	2	
46	O-Ring	2851237	2	
47	Back-Up Ring	2843047	1	
48	Upper Brass Retainer	T71 105	1	
49	Upper Seal Retainer	T71 108	1	
50	Step Seal	2811080	2	
51	Gas Seal	2835048	1	
52	Back-Up Ring	2842331	1	
53	O-Ring	2851201	2	
54	Select Valve	C71 309	1	
55	Back-Up Ring	2842201	1	
56	Socket Bolt	4011058	4	
57	Adjuster Cover	Q31 110	1	
58	Select Pin	Q31 112	1	
59	Rubber Spring	Q31 113	1	
60	Sping Pin	4300080	1	
61	Blanking Plug	N57 100	6	
62	Blanking Plug	N57 101	5	
63	Blanking Plug	C71 258	1	



■ Cylinder Set (SB160/921kg)

NO	PARTS NAME	P/N	Q' ty	REMARK
	Cylinder Set	T61 117	1SET	
5	Piston	T61 103	1	
6	Cylinder	T61 102	1	
9	O-Ring	2851212	1	
10	O-Ring	2851216	1	
11	Valve Plug	C71 204	1	
12	Valve	C71 202	1	
13	Valve Sleeve	C71 203	1	
14	Grease Nipple	2700411	1	
24	Accumulator ass' y	C71 434	1	
25	Helisert Coil	4131043	4	
26	Socket Bolt	4013227	4	
27	Air CheckValve	C71 277	1	
28	Adapter	C61 348	2	
29	O-Ring	2851043	2	
30	Union Cap	2715064	2	
31	O-Ring	2851202	2	
32	Hex Head Plug	Q11 191	2	
33	O-Ring	2851010	2	
34	O-Ring	2851015	1	
35	Valve Adjuster	C71 162	1	
36	Back-Up Ring	2841216	2	
37	Hex Nut	4101309	1	
38	Socket Plug	C71 121	3	
39	O-Ring	2850035	3	
43	Dust Seal	2831933	4	
44	U-Packing	2819113	4	
45	U-Packing	2819109	4	
46	O-Ring	2851237	1	
47	Back-Up Ring	2843047	1	
48	Upper Brass Retainer	T61 104	2	
49	Upper Seal Retainer	T61 107	1	
50	Step Seal	2811123	1	
51	Gas Seal	2835057	1	
52	Back-Up Ring	2842331	2	
53	O-Ring	2851201	1	
54	Select Valve	C71 309	1	
55	Back-Up Ring	2842201	2	
56	Socket Bolt	4011058	1	
57	Adjuster Cover	Q31 110	1	
58	Select Pin	Q31 112	1	
59	Rubber Spring	Q31 113	1	
60	Spring Pin	4300080	1	
61	Blanking Plug	N57 100	6	
62	Blanking Plug	N57 101	5	
63	Blanking Plug	C71 258	1	

■ Cylinder Set (SB177/1,209kg)

NO	PARTS NAME	P/N	Q' ty	REMARK
	Cylinder Set	B0006316	1SET	
5	Piston	B0006165	1	
6	Cylinder Plug Assembly	B0006162	1	
9	O-Ring, 1B G80	2851212	1	
10	O-Ring, 1B G100	2851216	1	
11	Valve Plug	C71204	1	
12	Valve	C71202	1	
13	Valve Sleeve	C71203	1	
14	Grease Nipple, Pt1/4	2700411	1	
24	Accumulator Assembly	B0001348	1	
25	Helisert Coil, M30X1,5 2D	4131043	4	
26	Bolt, Socket, M30X2,0X80	4013227	4	
27	Air Check Valve	C71277	1	
28	Adapter, #3 Type	C61348	2	
29	O-Ring, 1B P44	2851043	2	
30	Union Cap, #3 Type	2715064	2	
31	O-Ring, 1B G30	2851202	2	
32	Hex Head Plug	Q11191	2	
33	O-Ring, 1B P11	2851010	2	
34	O-Ring	2851019	1	
35	Valve Adjuster	B0004790	1	
36	Nut	B0004990	1	
37	Socket Plug	C71121	3	
38	O-Ring, 1A P35	2850035	3	
42	Seal,Dust	B0005749	1	
43	Packing,U	B0005750	1	
44	Packing,U	B0005751	2	
45	O-Ring	B0005752	3	
46	Back-Up Ring	B0005753	1	
47	Upper Brass Retainer	B0005745	1	
48	Upper Seal Retainer	B0005748	1	
49	Seal,Step	2811145	2	
50	Seal,Gas	2835066	1	

04. Front Head Set

■ Front Head Set (SB50~SB70)

NO	PARTS NAME	SB50		SB60		SB70	
		P/N	Q' ty	P/N	Q' ty	P/N	Q' ty
	Front Head Set	C11 327	1SET	C21 224	1SET	L01 704	1SET
24	Front Head	C11 193	1	C21 174	1	L01 147	1
25	Grease Nipple	2700411	1	←	1	←	1
27	Stop Pin	C11 131	1	C21 115	1	C21 115	1
28	Rubber Plug	D81 151	1	←	1	←	1
30	Ring Bush	SSC11182	1	SSC21151	1	SSL01110	1

■ Front Head Set (SB81~SB121)

NO	PARTS NAME	SB81		SB100		SB121	
		P/N	Q' ty	P/N	Q' ty	P/N	Q' ty
	Front Head Set	C31 527	1SET	E91 313	1SET	C61 473	1SET
24	Front Head	C31 256	1	E91 137	1	C61 278	1
25	Grease Nipple	2700411	1	←	1	←	1
27	Stop Pin	C31 127	1	E91 121	1	C61 169	1
28	Rubber Plug	C31 246	1	D81 151	1	←	1
30	Ring Bush	SSC31225	1	SSE91111	1	SSC61241	1
39	Hollow Hex Plug	—	—	—	—	2702221	1

■ Front Head Set (SB130,135,140P,140,151)

NO	PARTS NAME	SB130		SB135		SB140P		SB140		SB151	
		P/N	Q' ty	P/N	Q' ty	P/N	Q' ty	P/N	Q' ty	P/N	Q' ty
	Front Head Set	D81 305	1SET	D81 306	1SET	L21 312	1SET	C71 451	1SET		
24	Front Head	D81 177	1	D81 141	1	L21 111	1	C71 200	1		
25	Grease Nipple	2700411	1	←	1	←	1	←	1		
27	Stop Pin	C61 169	1	←	1	←	1	C61 168	1		
28	Rubber Plug	D81 151	1	←	1	D81 151	1	D81 150	1		
30	Ring Bush	SSD81124	1	SSC61241	1	SSD81124	1	SSC71167	1		
39	Hollow Hex Plug	2702221	2	←	2	2702221	2	2702221	2		

■ Front Head Set (SB147P,147,157,160)

NO	PARTS NAME	SB147P		SB147		SB157		SB160	
		P/N	Q' ty	P/N	Q' ty	P/N	Q' ty	P/N	Q' ty
	Front Head Set	T41 116	1SET	T51 117	1SET	T71 120	1SET	T61 136	1SET
3	Front Head	T41 103	1	T51 103	1	T71 101	1	←	1
4	Ring Bush	SST41106	1	SSD81124	1	SST71115	1	SST61114	1
14	Grease Nipple	2700411	1	←	1	←	1	←	1
17	Stop Pin	C61 169	1	←	1	C71 140	1	←	1
18	Rubber Plug	D81 151	1	←	1	D81 150	1	←	1
20	Blanking Plug	N57 103	1	←	2	←	1	←	1
23	Heilsert coil	Q01 115	4	←	4	←	4	←	4
21	Hollow Hex Plug	—	—	2702221	1	—	—	—	—

■ Front Head Set (SB177)

NO	PARTS NAME	SB177	
		P/N	Q'ty
	Front Head Set	B0001419	1SET
3	Front Head	B0001317	1
4	Ring Bush	B0001320	1
14	Grease Nipple, Pt1/4	2700411	1
17	Stop Pin	B0001416	1
18	Rubber Plug	D81150	1
20	Blank Plug, Pt3/4"	N57103	1

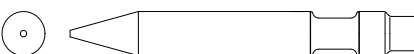
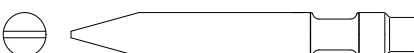
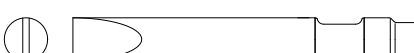
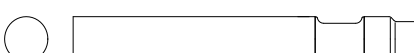

05. Rod type

PARTS NAME	SHAPE
MOIL POINT TYPE	
UNIVERSAL TYPE	
V-WEDGE TYPE	
H-WEDGE TYPE	
FLAT TYPE	

MODEL	TYPE	SIZE	PARTS No.				
			MOIL	UNIVERSAL	V-WEDGE	H-WEDGE	FLAT
SB10 II	LONG	D40 x L450	SSE81141	SSE81142	SSE81143	SSE81144	SSE81145
	SHORT	D40 x L400	SSE81146	SSE81147	SSE81148	SSE81149	SSE81150
SB20 II	LONG	D45 x L500	SSF01156	SSF01157	SSF01158	SSF01159	SSF01160
	SHORT	D45 x L450	SSF01161	SSF01162	SSF01163	SSF01164	SSF01165
SB30 II	LONG	D53 x L550	SSE71160	SSE71161	SSE71162	SSE71163	SSE71164
	SHORT	D53 x L500	SSE71165	SSE71166	SSE71167	SSE71168	SSE71169
SB35 II	LONG	D60 x L600	SSF81136	SSF81137	SSF81138	SSF81139	SSF81140
	SHORT	D60 x L550	SSF81141	SSF81142	SSF81143	SSF81144	SSF81145
SB40 II	LONG	D68 x L700	SSC0 220	SSC01221	SSC01222	SSC01223	SSC01224
	SHORT	D68 x L600	SSC01225	SSC01226	SSC01227	SSC01228	SSC01229
SB43 II	LONG	D75 x L800	SSF91144	SSF91145	SSF91146	SSF91147	SSF91148
	SHORT	D75 x L700	SSF91159	SSF91160	SSF91161	SSF91162	SSF91163
SB43B	LONG	D75 x L800	SSF91144	SSF91145	SSF91146	SSF91147	SSF91148
	SHORT	D75 x L700	SSF91159	SSF91160	SSF91161	SSF91162	SSF91163
SB45	LONG	D85 x L900	SSD41101	SSD41122	SSD41123	SSD41124	SSD41125
	SHORT	D85 x L800	SSD41155	SSD41156	SSD41158	SSD41159	SSD41157
SB50	LONG	D100 x L1000	SSC11195	SSC11196	SSC11198	SSC11199	SSC11197
	SHORT	D100 x L900	SSC11205	SSC11206	SSC11208	SSC11209	SSC11207
SB60	LONG	D125 x L1100	SSC21114	SSC21127	SSC21129	SSC21128	SSC21130
	SHORT	D125 x L1000	SSC21163	SSC21164	SSC21166	SSC21167	SSC21165
SB70 SB81NII	LONG	D135 x L1200	SSL01118	SSL01119	SSL01121	SSL01122	SSL01120
	SHORT	D135 x L1100	SSL01124	SSL01125	SSL01127	SSL01128	SSL01126
SB81 SB81A	LONG	D140 x L1300	SSC31211	SSC31212	SSC31214	SSC31213	SSC31215
	SHORT	D140 x L1200	SSC31241	SSC31242	SSC31244	SSC31245	SSC31243
SB100 SB100II	LONG	D150 x L1400	SSE91113	SSE91114	SSE91115	SSE91116	SSE91117
	SHORT	D150 x L1300	SSE91129	SSE91130	SSE91132	SSE91133	SSE91131
SB121	LONG	D155 x L1500	SSC61227	SSC61228	SSC61230	SSC61229	SSC61231
	SHORT	D155 x L1400	SSC61268	SSC61269	SSC61271	SSC61272	SSC61270
SB130 SB140 SB147	LONG	D165 x L1600	SSD81115	SSD81118	SSD81117	SSD81116	SSD81119
	SHORT	D165 x L1500	SSD81152	SSD81153	SSD81155	SSD81156	SSD81154
SB147P	LONG	D155 x L1600	SSC61293	SSC61308	SSC61310	SSC61309	SSC61311
	SHORT	D155 x L1500	SSC61227	SSC61228	SSC61230	SSC61229	SSC61231
SB151 SB157	LONG	D175 x L1600	SSC71157	SSC71158	SSC71160	SSC71159	SSC71161
	SHORT	D175 x L1500	SSC71189	SSC71190	SSC71192	SSC71193	SSC71191
SB160	LONG	D180 x L1600	SST61108	SST61134	SST61132	SST61130	SST61128
	SHORT	D180 x L1500	SST61127	SST61135	SST61133	SST61131	SST61129
SB177	LONG	D190 x L1600	SSB0001324	SSB0001326	SSB0001328	SSB0001330	SSB0001332
	SHORT	D190 x L1500	SSB0001325	SSB0001327	SSB0001329	SSB0001331	SSB0001333

06. Side type

■ SB10 II, 20 II, 30 II, 35 II, 43 II

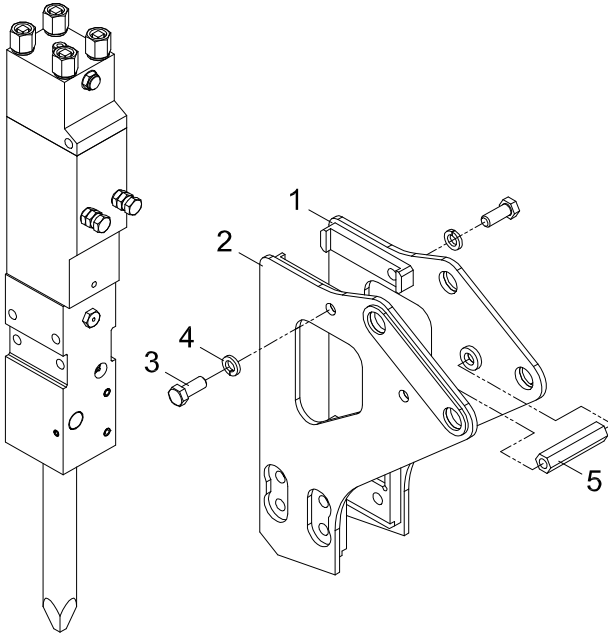

■ SB40 II

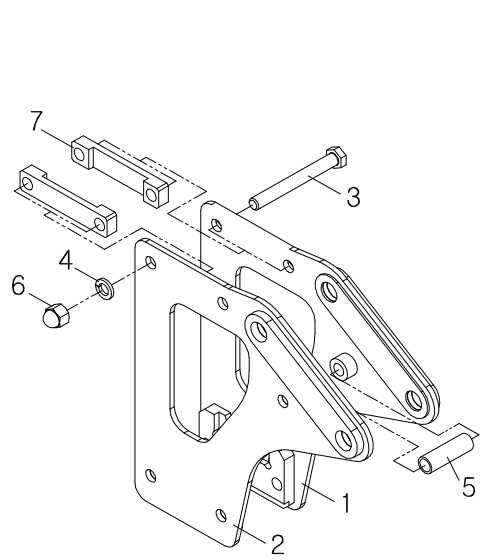

■ SB45

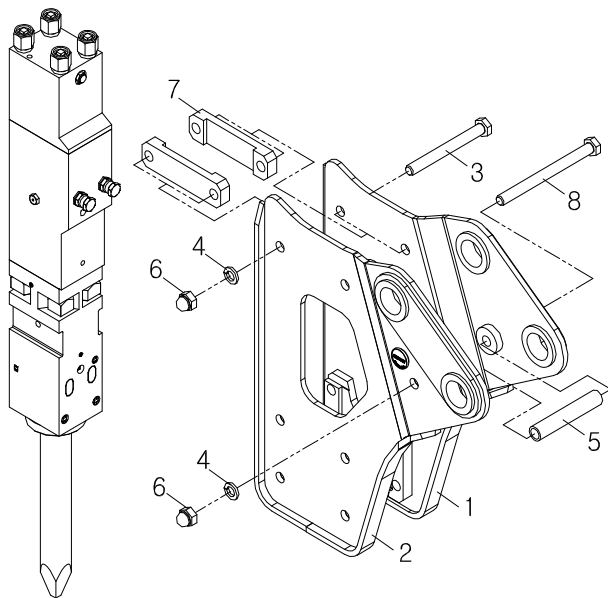

■ SB50

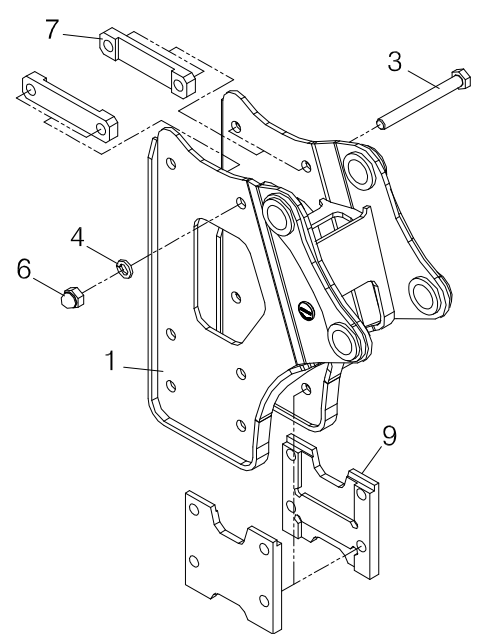

■ SIDE TYPE (SB10Ⅱ ~ SB50) - (#~) is applied Serial Number

NO	SB10Ⅱ (#116~)		SB20Ⅱ (#532~)		SB30Ⅱ (#425~)		SB35Ⅱ (#95~)		PARTS NAME	REMARK
	P/N	Q'ty	P/N	Q'ty	P/N	Q'ty	P/N	Q'ty		
	E82 000	1Set	F02 001	1Set	E72 004	1Set	F82 004	1Set	Side Sub Ass'y	
1	E82 100	1	F02 100	1	E72 119	1	F82 118	1	Side Bracket-R	
2	E82 101	1	F02 103	1	E72 120	1	F82 119	1	Side Bracket-L	
3	4003118	12	4005146	12	4004318	12	4004321	12	Hex Bolt	
4	4211014	12	4211015	12	4211016	12	4211016	12	Spring Washer	
5	E83 135	1	F02 107	1	E73 160	1	F82 111	1	Spacer	

NO	SB40Ⅱ (#7116~)		SB43Ⅱ (#98~)		SB45		SB50		PARTS NAME	REMARK
	P/N	Q'ty	P/N	Q'ty	P/N	Q'ty	P/N	Q'ty		
	C02 029	1Set	F92 001	1Set	D42 007(267) D42 011(225)	1Set	C12 019 (275) C12 021 (330) C12 025 (290)	1Set	Side Sub Ass'y	
1	C02 242	1	F92 100	1	D42 161(267) D42 180(225)	1	C12 249 (275) C12 266 (330) C12 282 (290)	1	Side Bracket-(R)	
2	C02 241	1	F92 101	1	D42 162(267) D42 181(225)	1	-	-	Side Bracket-L	
3	4003453	5	4004414	12	4003451	6	4003468	6	Hex Bolt	
4	4210019	5	4211019	12	4210020	7	4211022	6	Spring Washer	
5	C02 156	1	F93 102	1	-	-	-	-	Spacer	
6	4143010	5	-	-	4143011	7	4143013 (275,330) 4101313(290)	6	Hex Cap Nut	
7	C02 199	2	-	-	D42 170	2	C12 251	2	Guide Plate	
8	-	-	-	-	D43 120(267) D43 288(225)	1	-	-	Distance Pipe	
9	-	-	-	-	4003452(267) 4003320(225)	1	-	-	Hex Bolt	
10	-	-	-	-	-	-	C12 250	2	Set Plate	

■ SB60,70,81

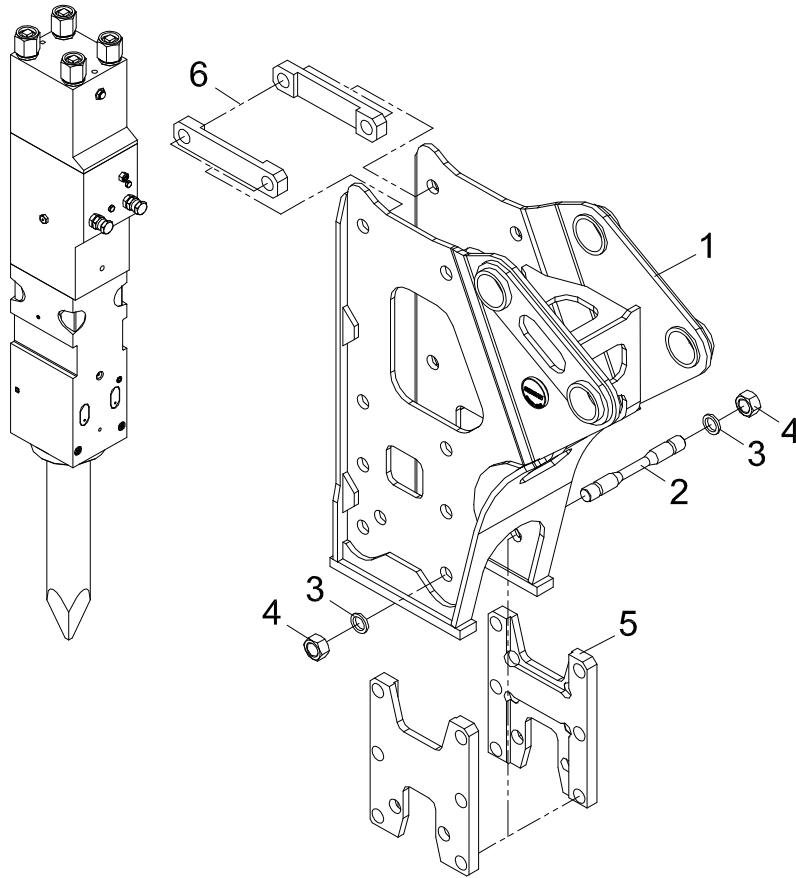

■ SIDE TYPE (SB60 ~ SB81)

NO	SB60		SB70		SB81		PARTS NAME	REMARK
	P/N	Q'ty	P/N	Q'ty	P/N	Q'ty		
	C22 019	1Set	L02 001	1Set	C32 038	1Set	Side Sub Ass'y	
1	C22 212	1	L02 100	1	C32 379	1	Side Bracket	
2	C22 103	8	L02 126	8	C32 211	8	Side Bolt	
3	C33 209	16	L03 153	16	C33 114	16	Washer	
4	C22 104	16	L02 119	16	C32 212	16	Side Nut	
5	C22 102	2	L02 102	2	C32 152	2	Set Plate	
6	C22 213	2	L02 101	2	C32 378	2	Guide Plate	
7	C22 225	1	L02 115	1	C32 257	1	Support Bar	

■ SB100,121,130,140,151

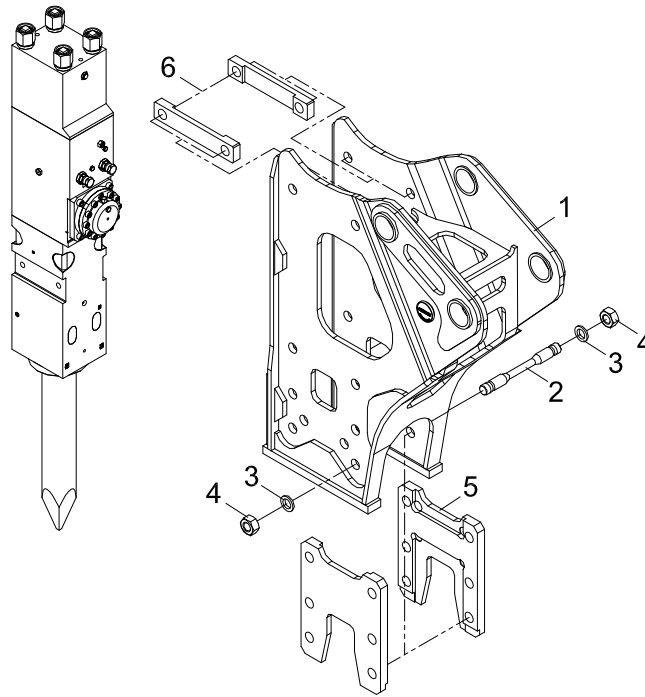

■ SIDE TYPE (SB100 ~ SB151)

NO	SB100		SB121		SB130		SB140		SB151		PARTS NAME	REMARK
	P/N	Q'ty	P/N	Q'ty	P/N	Q'ty	P/N	Q'ty	P/N	Q'ty		
	E92 001	1Set	C62 027	1Set	D82 015	1Set	L22 001	1Set	C72 072	1Set	Side Sub Ass'y	
1	E92 100	1	C62 276	1	D82 178	1	L22 100	1	C72 389	1	Side Bracket	
2	E92 114	8	D82 152	8	←	8	L22 103	8	C73 368	8	Side Bolt	
3	C33 114	16	D82 153	16	←	16	←	16	C73 118	16	Washer	
4	C32 212	16	C62 210	16	←	16	←	16	C73 367	16	Side Nut	
5	E92 113	2	C62 292	2	D82 179	2	L22 101	2	C72 378	-	Set Plate	
6	E92 116	2	C62 293	2	D82 154	2	L22 102	2	C72 199	2	Guide Plate	
7	E92 115	2	D82 112	1	←	1	L22 104	1	-	-	Support Bar	Not Use

■ SB147P,147,157,160

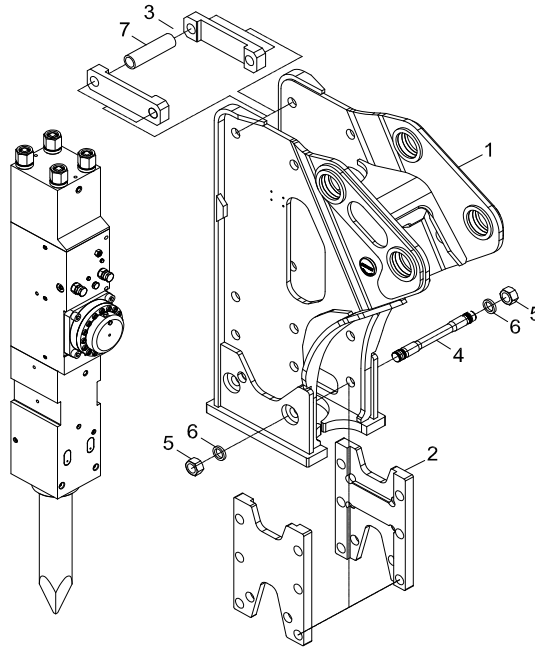

NO	SB147		SB147		SB160		PARTS NAME	REMARK
	P/N	Q'ty	P/N	Q'ty	P/N	Q'ty		
	T52 001	1Set	T72 001	1Set	B0001911	1Set	Side Sub Ass'y	
1	T52 100	1	T72 100	1	B0001893	1	Side Bracket	
2	L22 101	2	T72 111	2	B0002130	2	Set Plate	
3	L22 102	2	C72 199	2	B0001913	2	Guide Plate	
4	L22 103	8	C73 368	8	B0001912	10	Side Bolt	
5	C62 210	16	C73 367	16	C73367	20	Side Nut	
6	L22 162	16	C73 118	16	C73118	20	Washer	
7	L22 104	1	C72 674	1	C72674	1	Support Bart	

07. Backhoe type

■ SB40 II BACKHOE

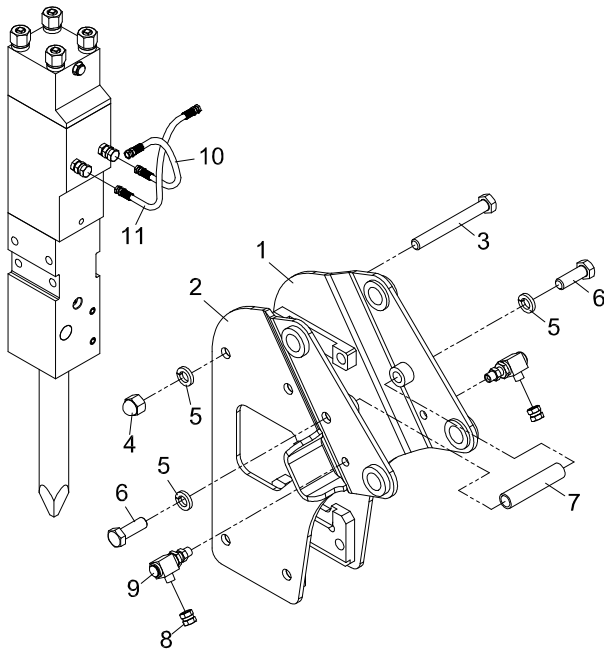

■ SB40 II BACKHOE(Heavy)

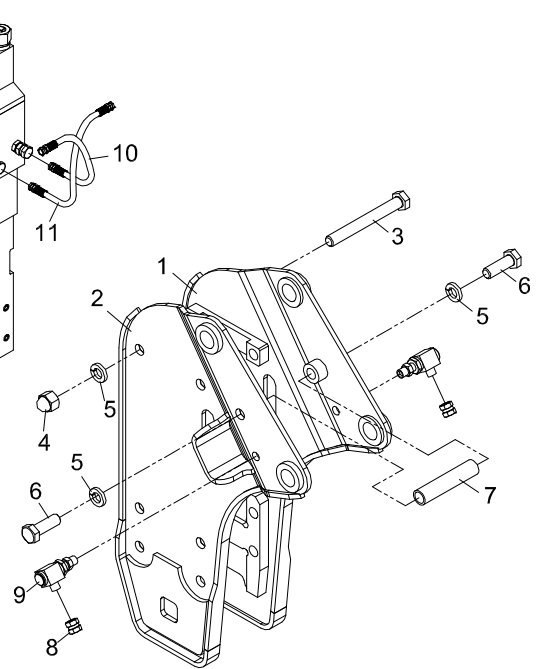

■ SB43 II BACKHOE

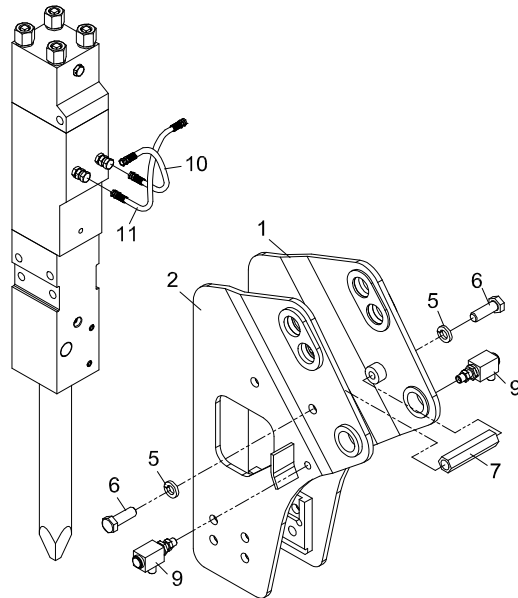



■ BACKHOE TYPE (SB40 ~ SB43)

NO	SB40 II BACKHOE		SB40 II BACKHOE (HEAVY)		SB43 II BACKHOE		PARTS NAME	REMARK
	P/N	Q'ty	P/N	Q'ty	P/N	Q'ty		
	C03 061	1Set	C03 063	1Set	F93 001	1Set	Frame Ass'y	
1	C03 402	1	C03 410	1	F93 100	1	Frame-R	
2	C03 403	1	C03 411	1	F93 101	1	Frame-L	
3	4003453	4	4003453	6	-	-	Hex Bolt	
4	4143010	4	4143010	6	-	-	Hex Cap Nut	
5	4211019	6	4211019	8	4211019	12	Spring Washer	
6	4004414	2	4004414	2	4004414	12	Hex Bolt	
7	F93 102	1	F93 102	1	F93 102	1	Spacer	
8	2715002	2	2715002	2	-	-	Union Cap	
9	C03 347	2	C03 347	2	C03 347	2	Swivel Adapter	
10	F93 190	1	F93 190	1	F93 190	1	Oil Hose-R	
11	F93 191	1	F93 191	1	F93 191	1	Oil Hose-L	

■ BACKHOE TYPE (SB45)

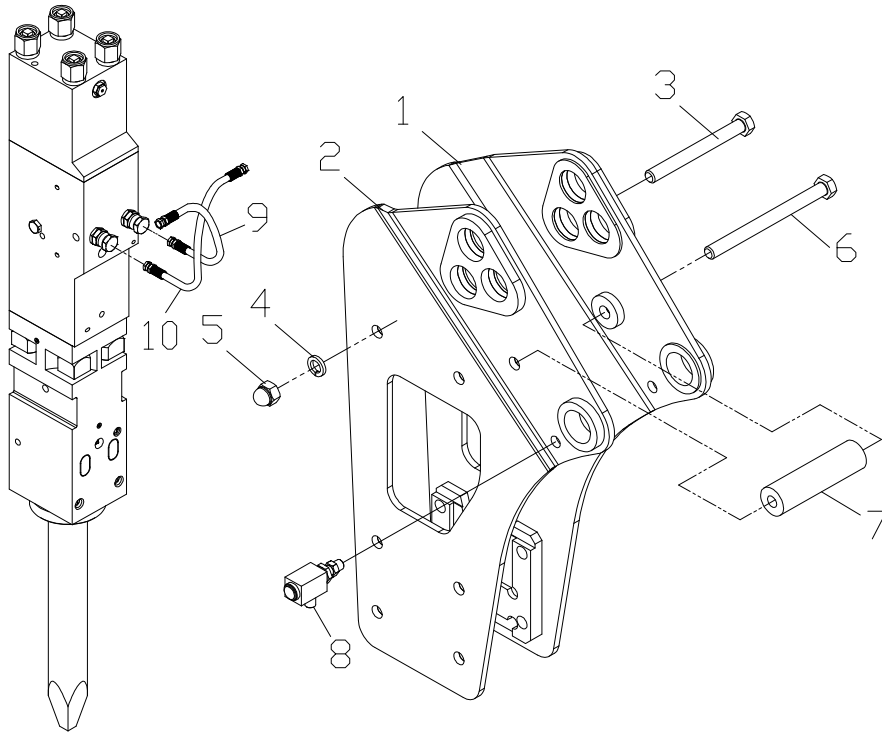

NO	SB45 BACKHOE		PARTS NAME	REMARK
	P/N	Q'ty		
	D43 030	1Set	Frame Ass'y	
1	D43 273	1	Frame-R	
2	D43 274	1	Frame-L	
3	4003451	6	Hex Bolt	
4	4211020	7	Spring Washer	
5	4143011	7	Hex Cap Nut	
6	4003452	1	Hex Bolt	
7	D43 120	1	Distance Pipe	
8	D43 279	2	Swivel Adapter	
9	D43 283	1	Oil Hose-R	
10	D43 284	1	Oil Hose-L	

■ SB40 II SILENCED BACKHOE

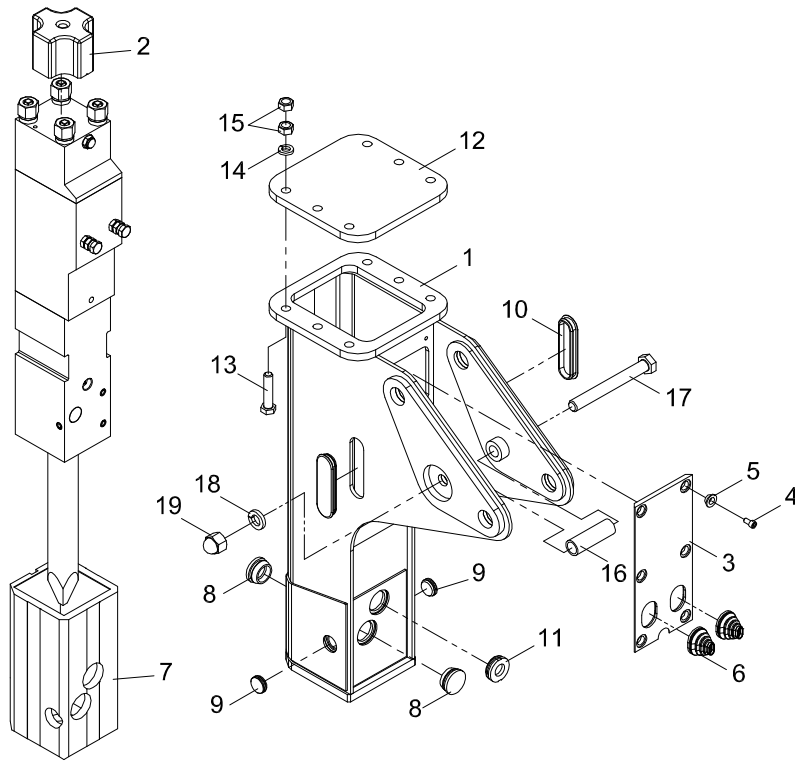

■ SB43 II SILENCED BACKHOE

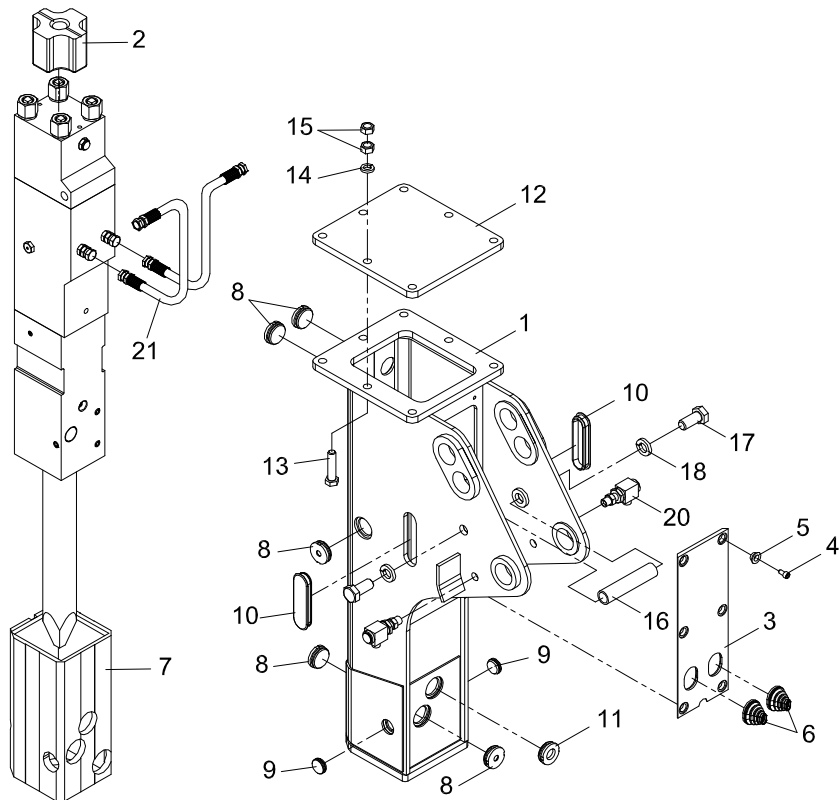

■ SILENCED BACKHOE (SB40 ~ SB43)

NO	SB40 II SILENCED BACKHOE (#7116~)			SB43 II SILENCED BACKHOE (#98~)			REMARK
	P/N	PARTS NAME	Q'ty	P/N	PARTS NAME	Q'ty	
	C03 065	Frame Ass'y	1Set	F93 013	Frame Ass'y	1Set	
1	C03 425	Frame	1	F93 169	Frame	1	
2	C03 229	Upper Cushion	1	←	Upper Cushion	1	
3	C03 302	Window Cover	1	F93 182	Window Cover	1	
4	4010060	Socket Bolt	6	←	Socket Bolt	6	
5	C03 282	Washer	6	←	Washer	6	
6	C03 295	Hose Cover	2	←	Hose Cover	2	
7	C03 376	Down Cushion	1	F93 115	Down Cushion	1	~'18,10
7	B0003435	Down Cushion	1	F93 115	Down Cushion	1	'18,11~
8	C03 228	Sound Plug	2	←	Sound Plug	5	
9	E73 116	Pin Plug	2	E73 116	Sound Plug	2	
10	F93 156	Hose Plug	2	C13 318	Sound Plug	2	
11	C03 360	Grease Plug	1	←	Sound Plug	1	
12	C02 278	Cover Plate	1	F93 183	Cover Plate	1	
13	4003183	Hex Bolt	6	←	Hex Bolt	7	
14	4211016	Spring Washer	6	←	Spring Washer	7	
15	4101307	Hex Nut	12	←	Hex Nut	14	
16	C02 156	Spacer	1	F93 102	Spacer	1	
17	4003453	Hex Bolt	1	4002389	Hex Bolt	2	
18	4211019	Spring Washer	1	←	Spring Washer	2	
19	4143010	Hex Cap Nut	1	←	Hex Cap Nut	1	
20	-	Swivel adapter	-	C03 347	Swivel adapter	2	
21	-	Oil Hose	-	2555209	Oil Hose	2	

■ SB43B SILENCED BACKHOE

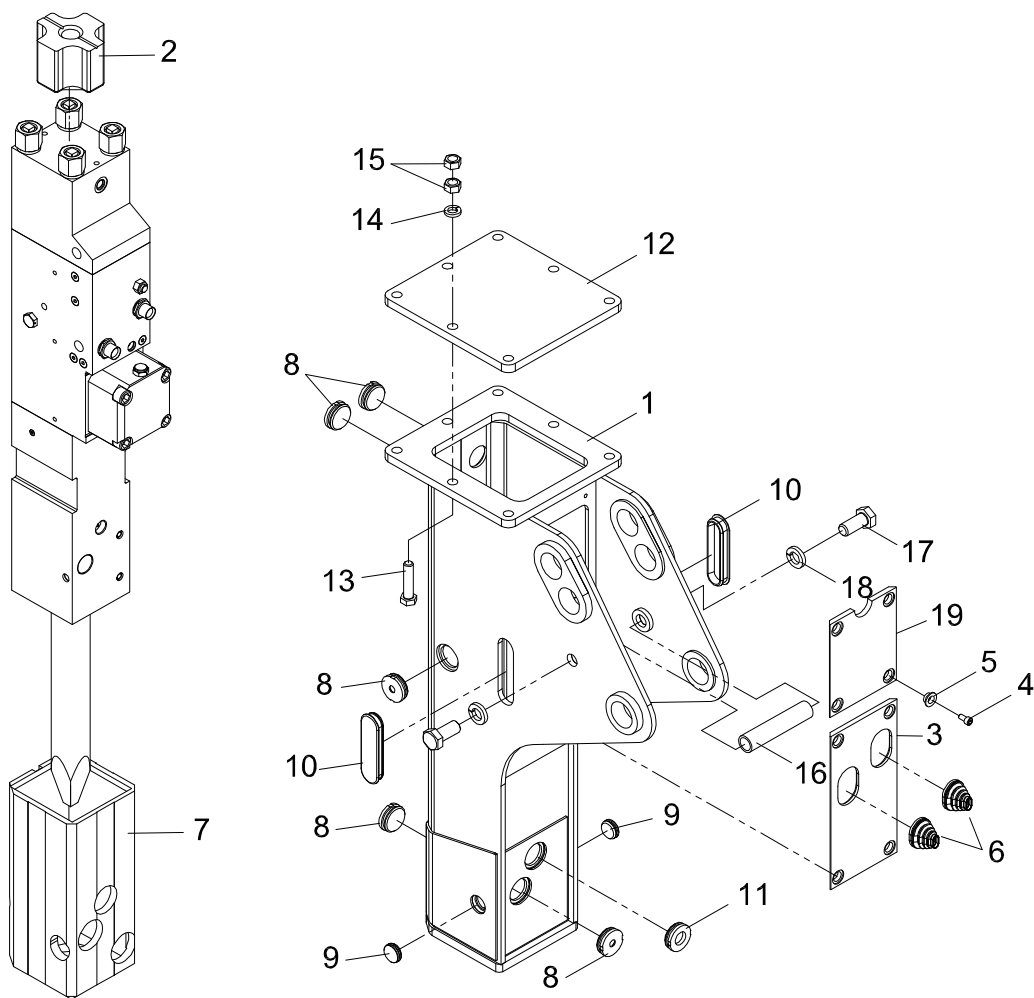

■ SILENCED BACKHOE (SB43B)

NO	SB43B SILENCED BACKHOE			REMARK
	P/N	PARTS NAME	Q'ty	
	F93 025	Frame Ass'y	1Set	
1	F93 247	Frame	1	
2	C03 229	Upper Cushion	1	
3	F93 253	Window Cover	1	
4	4010060	Socket Bolt	8	
5	C03 282	Washer	8	
6	C13 261	Hose Cover	2	
7	F93 115	Down Cushion	1	
8	C03 228	Sound Plug	5	
9	E73 116	Sound Plug	2	
10	C33 553	Sound Plug	2	
11	C03 360	Sound Plug	1	
12	F93 254	Cover Plate	1	
13	4003182	Hex Bolt	7	
14	4210016	Spring Washer	7	
15	4101307	Hex Nut	14	
16	F93 102	Spacer	1	
17	4002389	Hex Bolt	2	
18	4211019	Spring Washer	2	
19	F93 255	Window Cover-H	1	

08. Top type

8.1 Standard top type(Direct mounting)

■ SB10 II,20 II,30 II,35 II,43 II

■ SB40 II

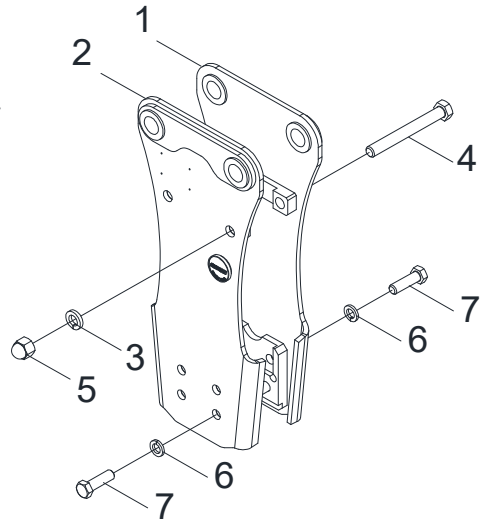
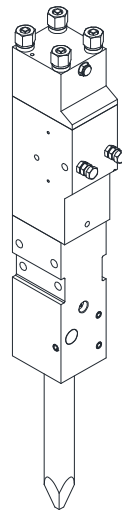
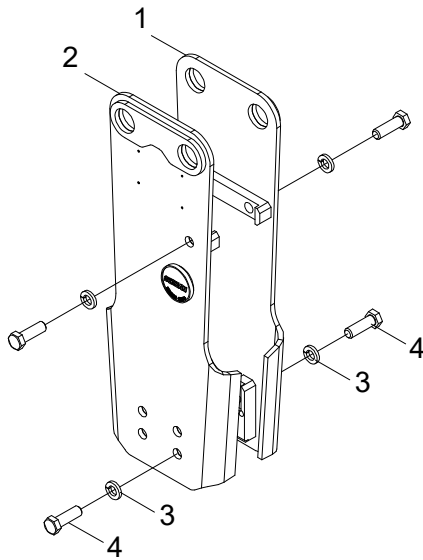
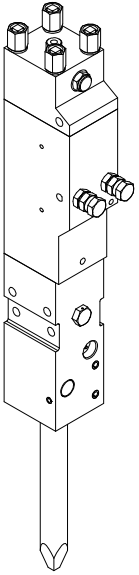

■ SB45, 50

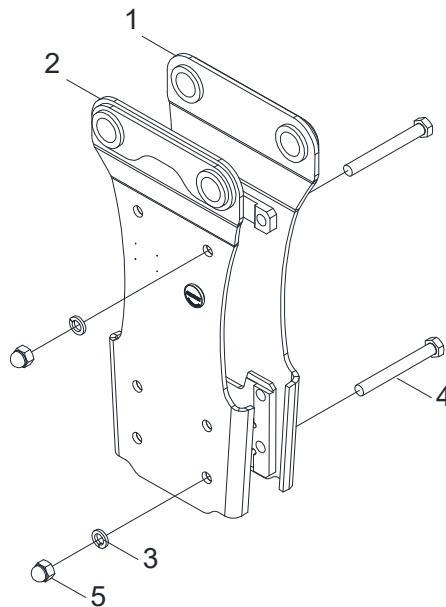
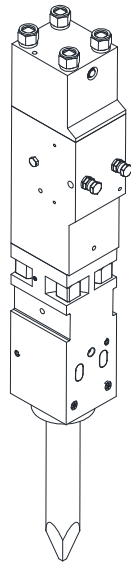

■ STANDARD TOP TYPE (SB10Ⅱ ~ SB50) : Direct mounting

NO	SB10Ⅱ (#116~)		SB20Ⅱ (#532~)		SB30Ⅱ (#425~)		SB35Ⅱ (#95~)		PARTS NAME	REMARK
	P/N	Q'ty	P/N	Q'ty	P/N	Q'ty	P/N	Q'ty		
	E83 016	1Set	F03 024	1Set	E73 025	1Set	F83 016	1Set	Frame Ass'y	
1	E83 184	1	F03 197	1	E73 218	1	F83 188	1	Frame-R	
2	E83 183	1	F03 196	1	E73 217	1	F83 187	1	Frame-L	
3	4211014	10	4211015	10	4211016	10	4211016	10	Spring Washer	
4	4003118	10	4005146	10	4004321	10	4004321	10	Hex Bolt	

NO	SB40Ⅱ (#7116~)		SB43Ⅱ (#98~)		SB45		SB50		PARTS NAME	REMARK
	P/N	Q'ty	P/N	Q'ty	P/N	Q'ty	P/N	Q'ty		
	C03 067	1Set	F93 019	1Set	D43 035	1Set	C13 041	1Set	Frame Ass'y	
1	C03 433	1	F93 196	1	D43 302	1	C13 390	1	Frame-R	
2	C03 434	1	F93 197	1	D43 303	1	C13 391	1	Frame-L	
3	4211019	2	4211019	10	4210020	6	4211022	6	Spring Washer	
4	4005453	2	4004414	10	4003451	6	4005464	7	Hex Bolt	
5	4143010	2	-	-	4143011	6	4143011	7	Cap Nut	
6	4211018	8	-	-	-	-	-	-	Spring Washer	
7	4002393	8	-	-	-	-	-	-	Hex Bolt	

8.2 Standard top type(Cap mounting)

■ SB10 II,20 II,30 II,35 II,43 II

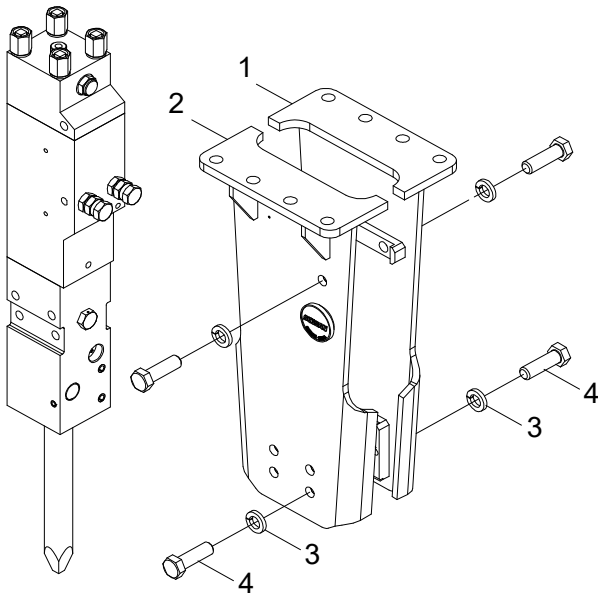

■ SB40 II

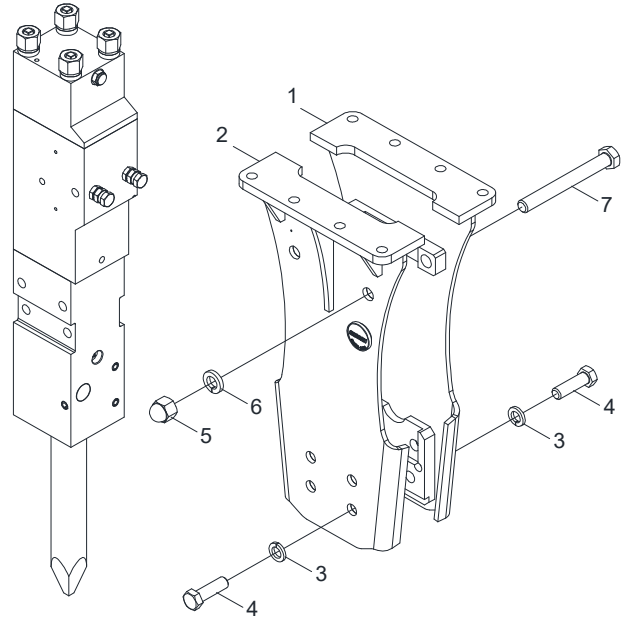

■ SB45

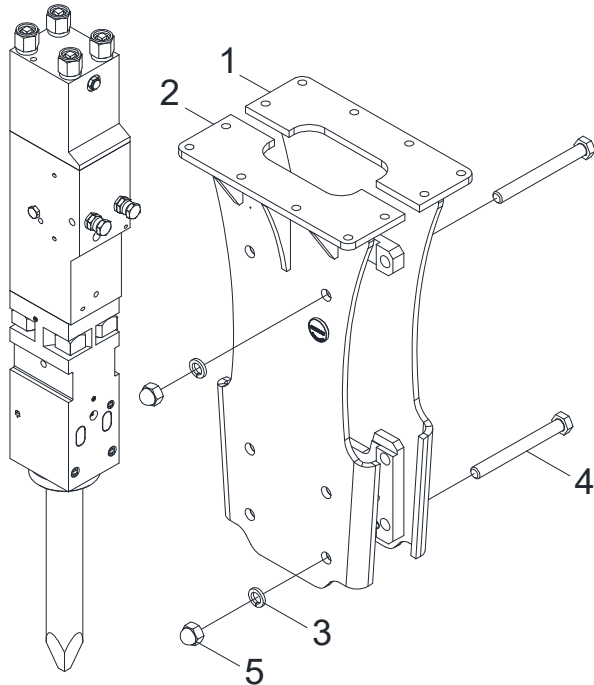

■ SB50

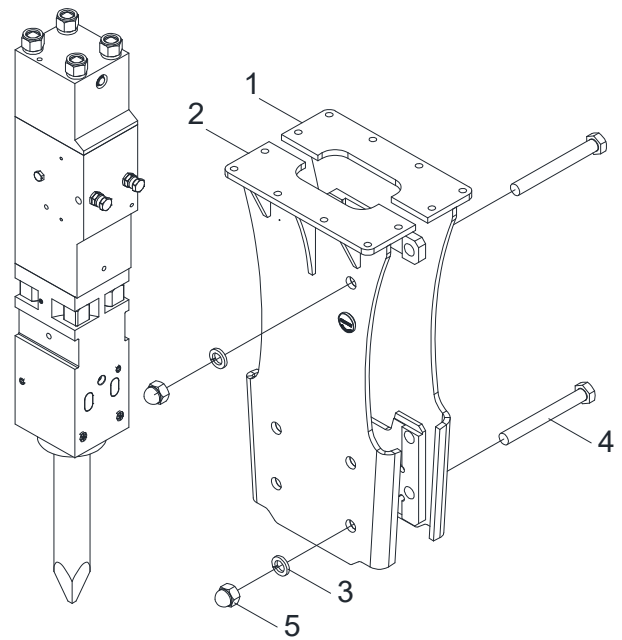

■ STANDARD TOP TYPE (SB10Ⅱ ~ SB50) : Cap mounting

NO	SB10Ⅱ (#116~)		SB20Ⅱ (#532~)		SB30Ⅱ (#425~)		SB35Ⅱ (#95~)		PARTS NAME	REMARK
	P/N	Q'ty	P/N	Q'ty	P/N	Q'ty	P/N	Q'ty		
	E83 017	1Set	F03 025	1Set	E73 026	1Set	F83 017	1Set	Frame Ass'y	
1	E83 189	1	F03 202	1	E73 227	1	F83 193	1	Frame-R	
2	E83 188	1	F03 201	1	E73 226	1	F83 194	1	Frame-L	
3	4211014	10	4211015	10	4211016	10	4211016	10	Spring Washer	
4	4003118	10	4003146	10	4004321	10	4004321	10	Hex Bolt	

NO	SB40Ⅱ (#7116~)		SB43Ⅱ (#98~)		SB45		SB50		PARTS NAME	REMARK
	P/N	Q'ty	P/N	Q'ty	P/N	Q'ty	P/N	Q'ty		
	C03 068	1Set	F93 020	1Set	D43 036	1Set	C13 043	1Set	Frame Ass'y	
1	C03 440	1	F93 202	1	D43 308	1	C13 397	1	Frame-R	
2	C03 441	1	F93 203	1	D43 309	1	C13 398	1	Frame-L	
3	4211019	8	4211019	10	4211020	6	4211022	6	Spring Washer	
4	4005453	8	4004414	10	4003451	6	4005464	7	Hex Bolt	
5	4143010	2	-	-	4143011	6	4143013	7	Cap Nut	
6	4211018	2	-	-	-	-	-	-	Spring Washer	
7	4002393	2	-	-	-	-	-	-	Hex Bolt	

8.3 Standard top type (TRENCH FINAL TYPE)

■ SB50TR-F

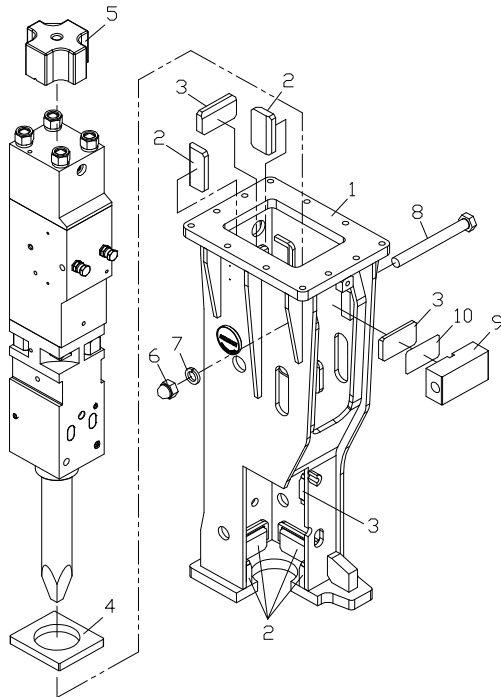

■ SB60,70,81,81A TR-F

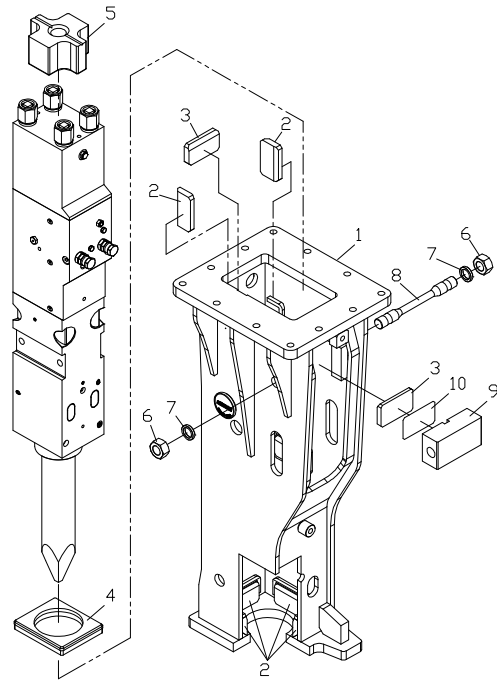

■ SB100,121,130,140,151 TR-F

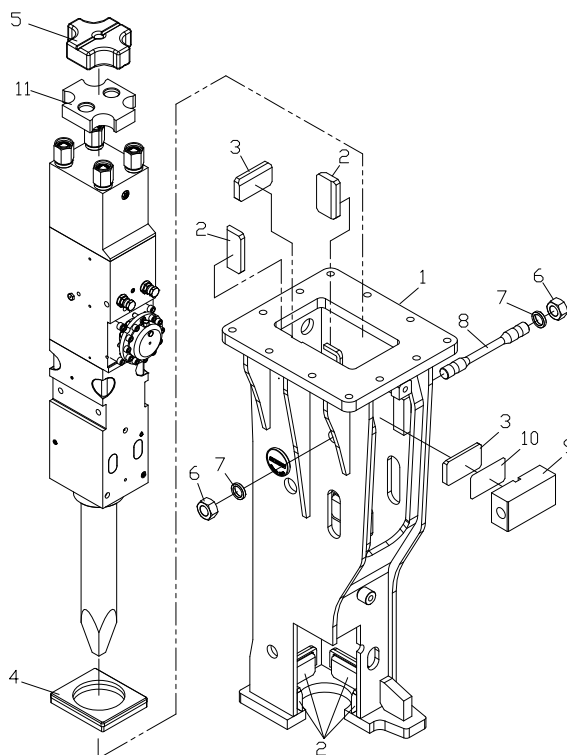

■ TRENCH FINAL TYPE (SB50 ~ SB151)

NO	SB50 (#11393~)		SB60 (#2478~)		SB70 (#5220~)		SB81 (#10355~)		SB81A (#6037~)		PARTS NAME
	P/N	Q'ty	P/N	Q'ty	P/N	Q'ty	P/N	Q'ty	P/N	Q'ty	
	C13 052	1Set	C23 065	1Set	L03 018	1Set	C36 007	1Set	C36 008	1Set	Frame Ass' y
1	C13 458	1	C23 553	1	L03 305	1	C33 870	1	C33 885	1	Frame
2	C33 824	6	←	6	←	6	←	6	←	6	Wear Plate(D/C)
3	C33 871	6	←	6	←	6	←	6	←	6	Wear Plate
4	C13 462	1	C23 556	1	L03 308	1	C33 872	1	←	1	Down Cushion
5	C13 204	1	C23 184	1	L03 101	1	C33 350	1	←	1	Upper Cushion
6	(C13 439)	1	C22 173	2	←	2	C32 212	2	←	2	Side Nut (Hex Nut)
7	4211022	1	C33 209	2	←	2	C33 114	2	←	2	Washer
8	(4003468)	1	C22 172	1	C23 358	1	C32 211	1	←	1	Side Bolt (Hex Bolt)
9	C13 439	1	C23 536	1	L03 260	1	C33 825	1	←	1	Support Bar
10	C12 438	1	←	1	←	1	←	1	←	1	Inner W/P Shim

NO	SB100 (#2225~)		SB121 (#5714~)		SB130 (#3439~)		SB140 (#1704~)		SB151 (#1132~)		PARTS NAME
	P/N	Q'ty	P/N	Q'ty	P/N	Q'ty	P/N	Q'ty	P/N	Q'ty	
	E93 021	1Set	C63 072	1Set	D83 039	1Set	L23 014	1Set	C73 037	1Set	Frame Ass' y
1	E93 423	1	C63 553	1	D83 446	1	L23 271	1	C73 563	1	Frame
2	L23 224	6	←	6	←	6	←	6	←	6	Wear Plate(D/C)
3	L23 277	6	←	6	←	6	←	6	←	6	Wear Plate
4	E93 420	1	C63 550	1	D83 441	1	L23 274	1	C73 546	1	Down Cushion
5	C63 390	1	C63 390	1	D83 258	1	D83 258	1	C73 314	1	Upper Cushion
6	C32 212	2	C62 210	2	C62 210	2	C62 210	2	C62 210	2	Side Nut (Hex Nut)
7	C33 114	2	C62 260	2	C62 260	2	C62 260	2	C62 260	2	Washer
8	C32 211	1	C63 526	1	C62 209	1	C62 209	1	D83 313	1	Side Bolt (Hex Bolt)
9	E93 364	1	C63 825	1	L23 225	1	L23 225	1	C73 458	1	Support Bar
10	C12 438	1	D82 337	1	D82 337	1	D82 337	1	D82 337	1	Inner W/P Shim
11	E93 224	1	C63 391	1	D83 259	1	L22 142	1	C73 320	1	Upper Cushion Guide

■ SB147,157,160 TR-F

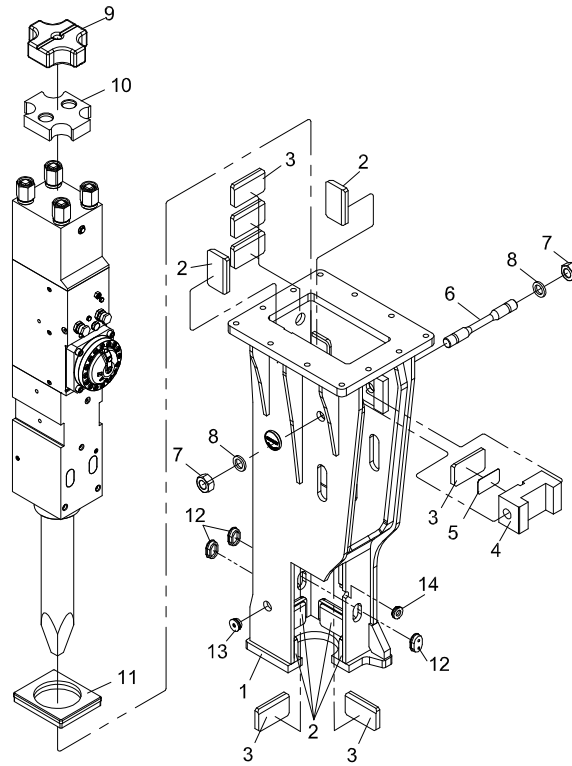

■ 177 TR-F

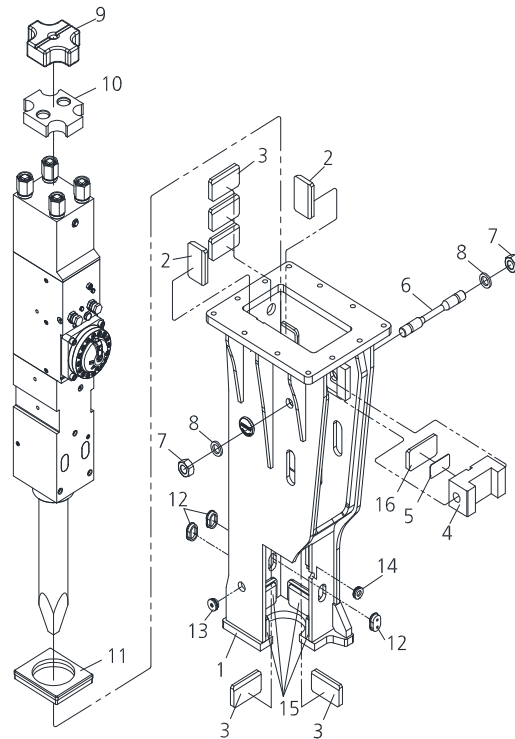

■ TRENCH FINAL TYPE (147,157, 177)

NO	SB147		SB157		SB177		PARTS NAME	REMARK
	P/N	Q'ty	P/N	Q'ty	P/N	Q'ty		
	T53 001	1Set	T73 001	1Set	B0006344	1Set	Frame Ass' y	
1	T53 100	1	T73 100	1	B0006345	1	Frame	
2	L23 302	6	C73 595	6	C73 205	2	Wear Plate(D/C)	
3	L23 303	6	C73 596	7	C73 206	5	Wear Plate	
4	L23 301	1	C73 594	1	T83 110	1	Support Bar	
5	D82 337	1	←	1	C73 334	1	Inner W/P Shim	
6	C63 209	1	D83 313	1	B0006347	1	Side Bolt	
7	C62 210	2	←	2	C73 367	2	Side Nut	
8	C62 260	2	←	2	C73 118	2	Washer	
9	D83 258	1	C73 314	1	C73 314	1	Upper Cushion	
10	L22 142	1	C73 320	1	C73 320	1	Upper Cushion Guide	
11	L23 274	1	C73 546	1	C73 546	1	Down Cushion	
12	C63 211	4	←	4	C63 211	4	Rod Plug	
13	C03 228	2	←	2	C03 228	2	Pin Plug	
14	C03 360	1	←	1	C03 360	1	Grease Plug	
15	-	-	-	-	T83 130	4	Wear Plate(D/C)	
16	-	-	-	-	C73 327	1	Wear Plate	

8.4 TS-P type

■ SB10 II, 20 II TS-P

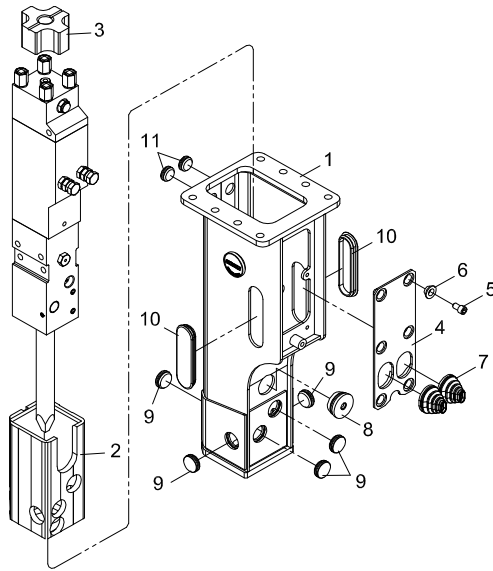

■ SB30 II, 35 II TS-P

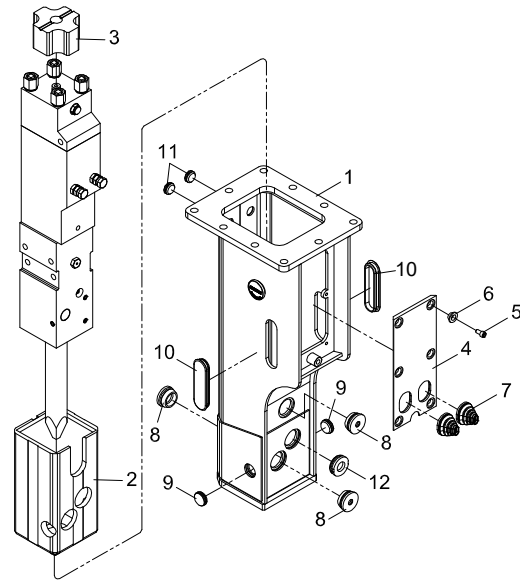

■ TS-P TYPE (SB10 II TS-P ~ SB35 II TS-P)

NO	SB10 II TS-P (#116~)		SB20 II TS-P (#532~)		SB30 II TS-P (#425~)		SB35 II TS-P (#95~)		PARTS NAME	REMARK
	P/N	Q'ty	P/N	Q'ty	P/N	Q'ty	P/N	Q'ty		
	E83 018	1Set	F03 026	1Set	E73 027	1Set	F83 018	1Set	Frame Ass'y	
1	E83 198	1	F03 210	1	E73 236	1	F83 205	1	Frame	
2	E83 125	1	F03 115	1	E73 202	1	F83 166	1	Down Cushion	~'18,10
2	E83 125	1	F03 115	1	E73 202	1	B0003343	1	Down Cushion	'18,11~
3	F03 116	1	←	1	E73 114	1	F83 118	1	Upper Cushion	
4	E83 141	1	F03 147	1	E73 173	1	F83 119	1	Window Cover	
5	4010060	6	4010060	6	←	6	←	6	Socket Bolt	
6	C03 282	6	←	6	←	6	←	6	Washer	
7	C03 295	2	←	2	←	2	←	2	Hose Cover	
8	C03 228	1	←	1	←	3	←	3	Sound Plug	
9	E73 116	5	←	5	←	2	←	2	Sound Plug	
10	E73 187	2	←	2	←	2	F93 156	2	Sound Plug	
11	E83 165	2	←	2	←	2	←	2	Sound Plug	
12	-	-	-	-	C03 360	1	←	1	Sound Plug	

■ SB40 II TS-P

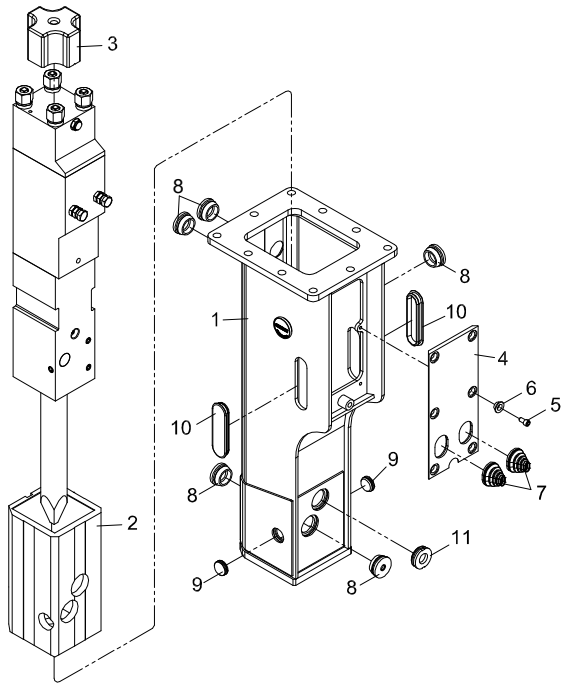

■ SB43 II TS-P

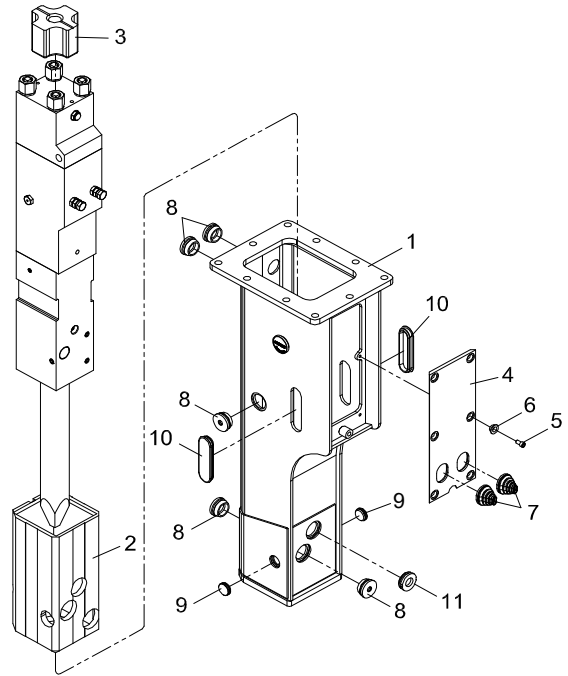

■ TS-P TYPE (SB40 II, 43 II TS-P)

NO	SB40 II TS-P (#7116~)		SB43 II TS-P (#98~)		PARTS NAME	REMARK
	P/N	Q'ty	P/N	Q'ty		
	C03 069	1Set	F93 021	1Set	Frame Ass'y	
1	C03 448	1	F93 211	1	Frame	
2	C03 376	1	F93 115	1	Down Cushion	~'18,10
2	B0003435	1	F93 115	1	Down Cushion	'18,11 ~
3	C03 229	1	←	1	Upper Cushion	
4	C03 302	1	F93 114	1	Window Cover	
5	4010060	6	←	6	Socket Bolt	
6	C03 282	6	←	6	Washer	
7	C03 295	2	←	2	Hose Cover	
8	C03 228	5	←	5	Sound Plug	
9	E73 116	2	←	2	Sound Plug	
10	F93 156	2	←	2	Sound Plug	
11	C03 360	1	←	1	Sound Plug	

■ SB45TS-P

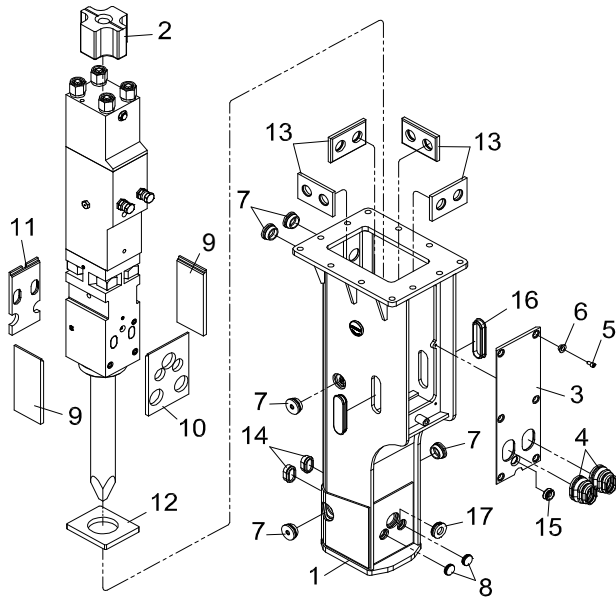

■ SB50TS-P

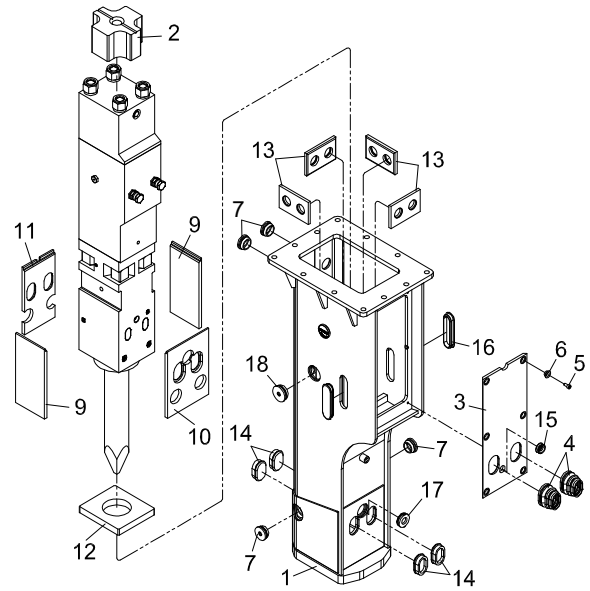

■ TS-P TYPE (SB45,50TS-P)

NO	SB 45TS-P		SB 50TS-P		PARTS NAME	REMARK
	P/N	Q'ty	P/N	Q'ty		
	D43 037	1Set	C13 045	1Set	Frame Ass'y	
1	D43 319	1	C13 410	1	Frame	
2	D43 153	1	C13 204	1	Upper Cushion	
3	D43 244	1	C13 302	1	Window Cover	
4	C13 261	2	←	2	Hose Cover	
5	4010060	6	←	6	Socket Bolt	
6	C03 282	6	←	6	Washer	
7	C03 228	5	←	4	Sound Plug	
8	E73 116	2	-	-	Sound Plug	
9	D43 245	2	C13 267	2	Wear Plate	
10	D43 246	1	C13 268	1	Wear Plate	~" 18,10
10	B0003342	1	C13 268	1	Wear Plate	'18,11 ~
11	D43 247	1	C13 269	1	Wear Plate	
12	D43 292	1	C13 331	1	Down Cushion	
13	C13 270	4	←	4	Wear Plate	
14	D43 249	2	C13 196	4	Sound Plug	
15	C23 324	1	←	1	Plug	
16	C13 318	2	←	2	Sound Plug	
17	C03 360	1	←	1	Sound Plug	
18	-	-	C23 219	1	Sound Plug(L)	

■ SB60,70,81,81A TS-P

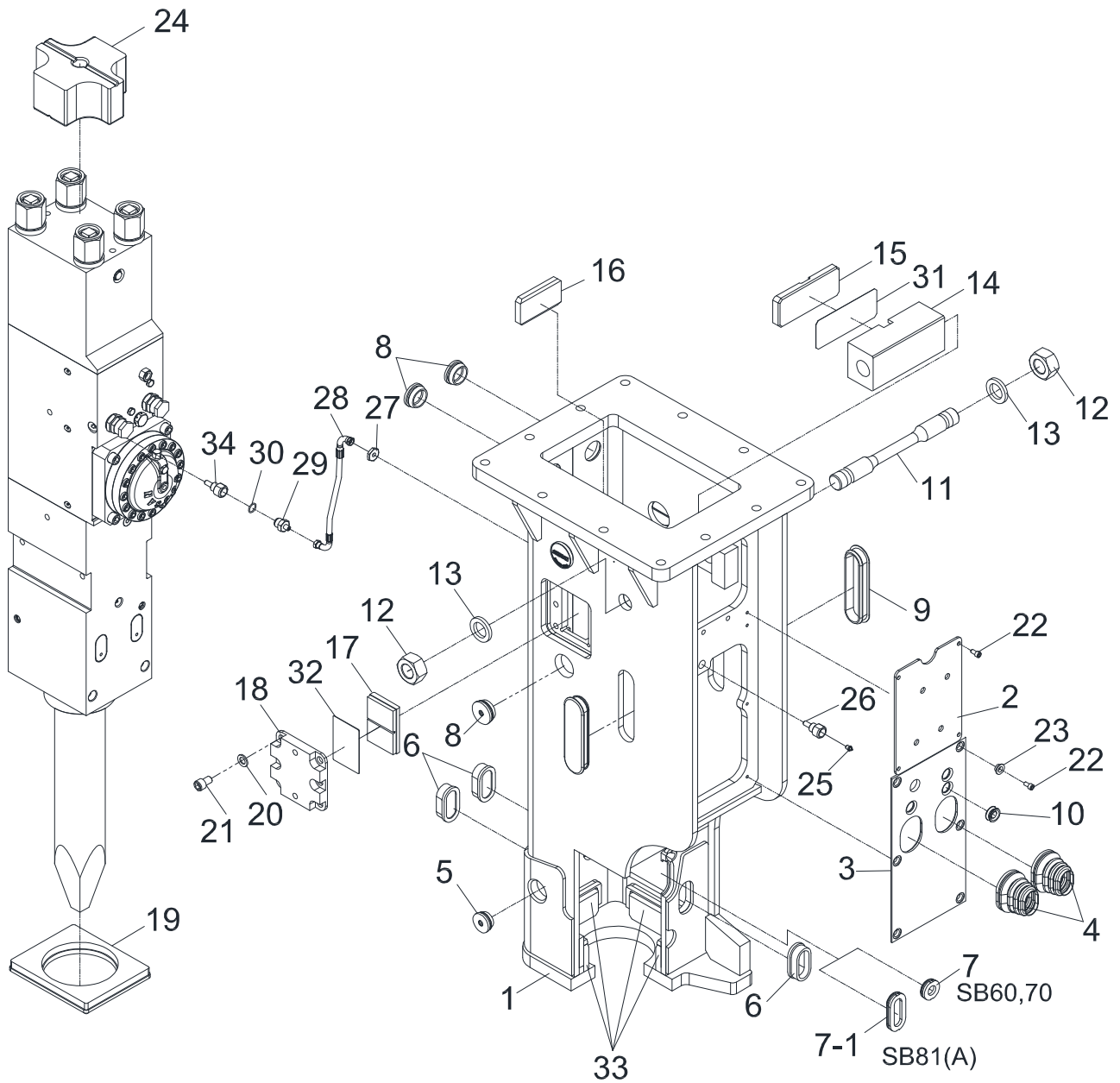

■ TS-P TYPE (SB60TS-P ~ SB81A TS-P)

NO	SB60 (#2436~)		SB70 (#5219~)		SB81(#10394~) SB81A(#6104~)		PARTS NAME	REMARK
	P/N	Q'ty	P/N	Q'ty	P/N	Q'ty		
	C23072	1Set	L03034	1Set	C36065	1Set	Frame Ass'y	
1	C23568	1	L03318	1	C33894	1	Frame	
2	C23582	1	L03192	1	C33995	1	Window Cover-H	
3	C23552	1	L03304	1	C33864	1	Window Cover-L	
4	C23279	2	←	2	←	2	Hose Cover	
5	C03228	2	←	2	←	2	Pin Plug	
6	C23181	4	C33339	4	←	4	Rod Plug	
7	C03360	1	←	1	-	-	Grease Plug	
7-1	—		-	-	C33902	1	Grease Plug	
8	C23219	3	←	3	←	3	Check Plug	
9	C33553	2	←	2	←	2	Hose Plug	
10	C23324	3	←	3	←	3	Window Plug	
11	C23426	1	C32211	1	E92114	1	Side Bolt	
12	C22235	2	L02119	2	C32212	2	Side Nut	
13	C22236	2	L03153	2	C33114	2	Washer	
14	L03199	1	C33649	1	←	1	Support Bar	
15	L03200	1	C33650	1	←	1	Support Wear Plate	
16	L03185	3	←	3	←	3	Inner Wear Plate	
17	E93235	1	←	1	←	1	Side Wear Plate	
18	E93253	1	←	1	←	1	W/P Holder	
19	C23556	1	L03308	1	C33872	1	Down Cushion	
20	4220008	6	←	6	←	6	Dish Spring Washer	
21	4011143	6	←	6	←	6	Socket Bolt	
22	4010060	8	←	10	←	10	Socket Bolt	
23	C03282	4	←	6	←	6	Washer	
24	C23184	1	L03101	1	C33350	1	Upper Cushion	
25	2700403	1	←	1	←	1	Grease Nipple	
26	E93367	1	←	1	←	1	Grease Adapter	
27	E93368	1	←	1	←	1	Nut	
28	E93369	1	←	1	←	1	Oil Hose	
29	E93366	1	←	1	←	1	G-Adapter	
30	2851018	1	←	1	←	1	O-Ring	
31	L03202	-	C33652	-	←	-	Support Shim	
32	L03190	-	←	-	←	-	W/P Shim	
33	C33900	4	←	4	←	1	InnerWear Plate(D/C)	
34	C75110	1	←	1	←	1	H&L Adapter	

■ SB100,121,130,140,151 TS-P

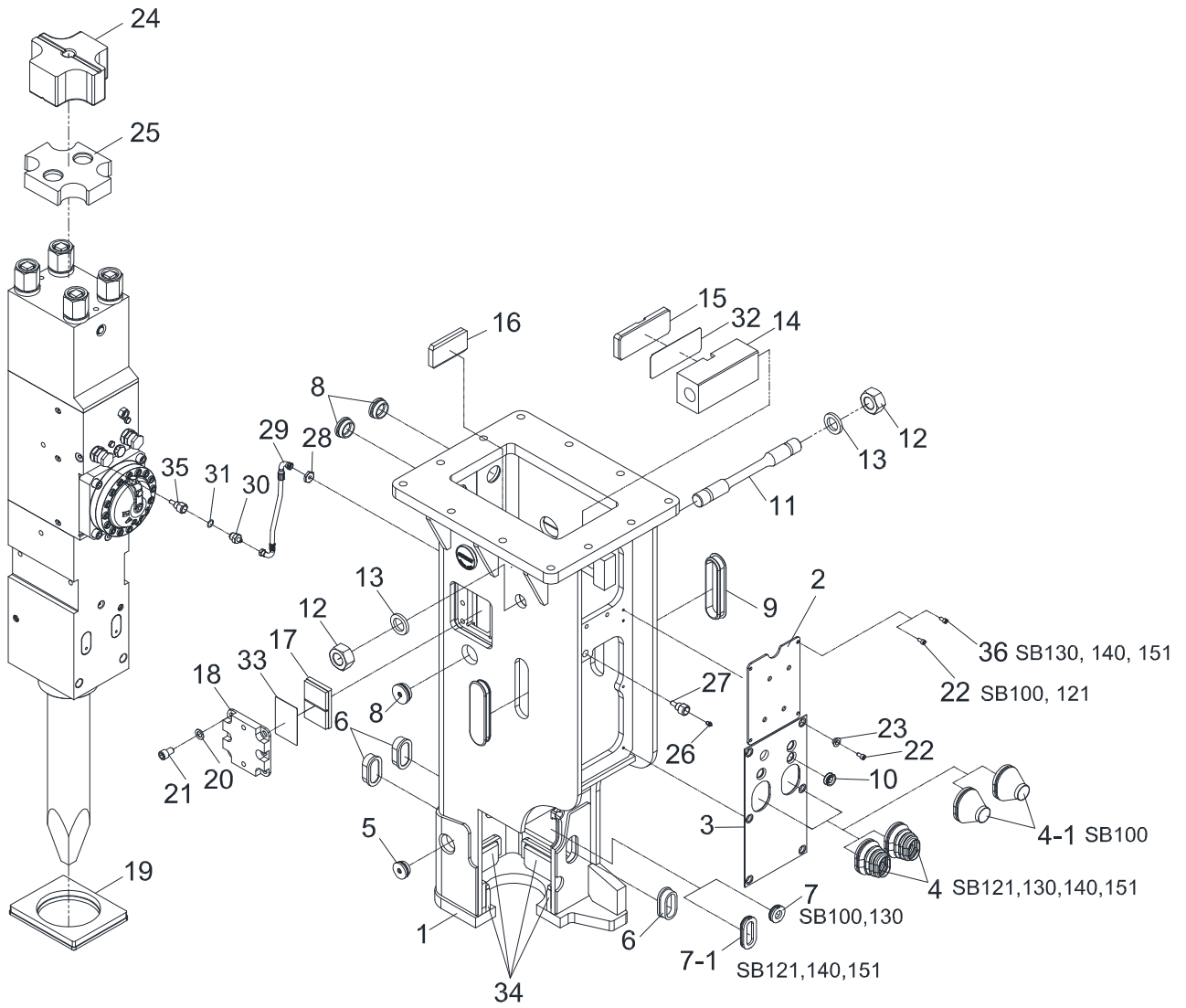

■ TS-P TYPE (SB100TS-P ~ SB151TS-P)

NO	SB100TS-P (#2182~)		SB121TS-P (#5573~)		SB130TS-P (#3462~)		SB140TS-P (#1717~)		SB151TS-P (#1183~)		PARTS NAME	REMARK
	P/N	Q'ty	P/N	Q'ty	P/N	Q'ty	P/N	Q'ty	P/N	Q'ty		
	E93056	1Set	C63084	1Set	D83046	1Set	L23047	1Set	C73089	1Set	Frame Ass'y	
1	E93431	1	C63562	1	D83452	1	L23370	1	C73671	1	Frame	
2	E93511	1	C63615	1	D83481	1	L23369	1	C73670	1	Window Cover-H	
3	E93403	1	C63546	1	D83432	1	L23256	1	C73493	1	Window Cover-L	
4	-	-	D83152	2	-	2	-	2	-	2	Hose Cover	
4-1	C23279	2	-	-	-	-	-	-	-	-	Hose Cover	
5	C03228	2	-	2	-	2	-	2	-	2	Pin Plug	
6	C63211	4	-	4	-	4	-	4	-	4	Rod Plug	
7	C03360	1	L23292	1	C03360	1	L23292	1	C33902	1	Grease Plug	
8	C23219	4	-	4	-	3	-	4	-	4	Check Plug	
9	C63339	2	-	2	-	2	-	2	C73267	2	Hose Plug	
10	C23324	3	-	3	-	3	-	3	-	3	Window Plug	
11	E93241	1	D83313	1	-	1	L23179	1	C73368	1	Side Bolt	
12	C32212	2	C62300	2	-	2	C73367	2	-	2	Side Nut	
13	C33114	2	C62301	2	-	2	C73118	2	-	2	Washer	
14	C33649	1	C63415	1	-	1	C73326	1	-	1	Support Bar	
15	C33650	1	C63416	1	-	1	C73327	1	-	1	Support Wear Plate	
16	L03185	3	C73313	3	-	3	-	8	-	8	Inner Wear Plate	
17	E93235	1	C73348	1	-	1	-	2	-	2	Side Wear Plate	
18	E93253	1	C73366	1	-	1	-	2	-	2	W/P Holder	
19	E93420	1	C63550	1	D83441	1	L23274	1	C73546	1	Down Cushion	
20	4220008	6	-	6	-	6	-	12	-	12	Dish Spring Washer	
21	4011143	6	4011145	6	-	6	-	12	-	12	Socket Bolt	
22	4010060	10	-	10	-	6	-	6	-	6	Socket Bolt	
23	C03282	6	-	6	-	6	-	6	-	6	Washer	
24	C63390	1	-	1	D83258	1	-	1	C73314	1	Upper Cushion	
25	E93224	1	C63391	1	D83259	1	L22142	1	C73320	1	Upper Cushion Guide	
26	2700411	1	-	1	-	1	-	1	-	1	Grease Nipple	
27	E93367	1	-	1	-	1	-	1	-	1	Grease Adapter	
28	E93368	1	-	1	-	1	-	1	-	1	Nut	
29	E93370	1	E93371	1	-	1	E93372	1	-	1	Oil Hose	
30	E93366	1	-	1	-	1	-	1	-	1	G-Adapter	
31	2851018	1	-	1	-	1	-	1	-	1	O-Ring	
32	C33652	-	C63419	-	-	-	C73334	-	-	-	Support Shim	
33	L03190	-	D83263	-	-	-	-	-	-	-	W/P SHIM	
34	E93437	4	-	4	-	4	-	4	-	4	Inner Wear Plate(D/C)	
35	C75110	1	-	1	-	1	-	1	-	1	H&L Adapter	
36	-	-	-	-	4011074	4	-	4	-	6	Socket Bolt	

■ SB147,157TS-P

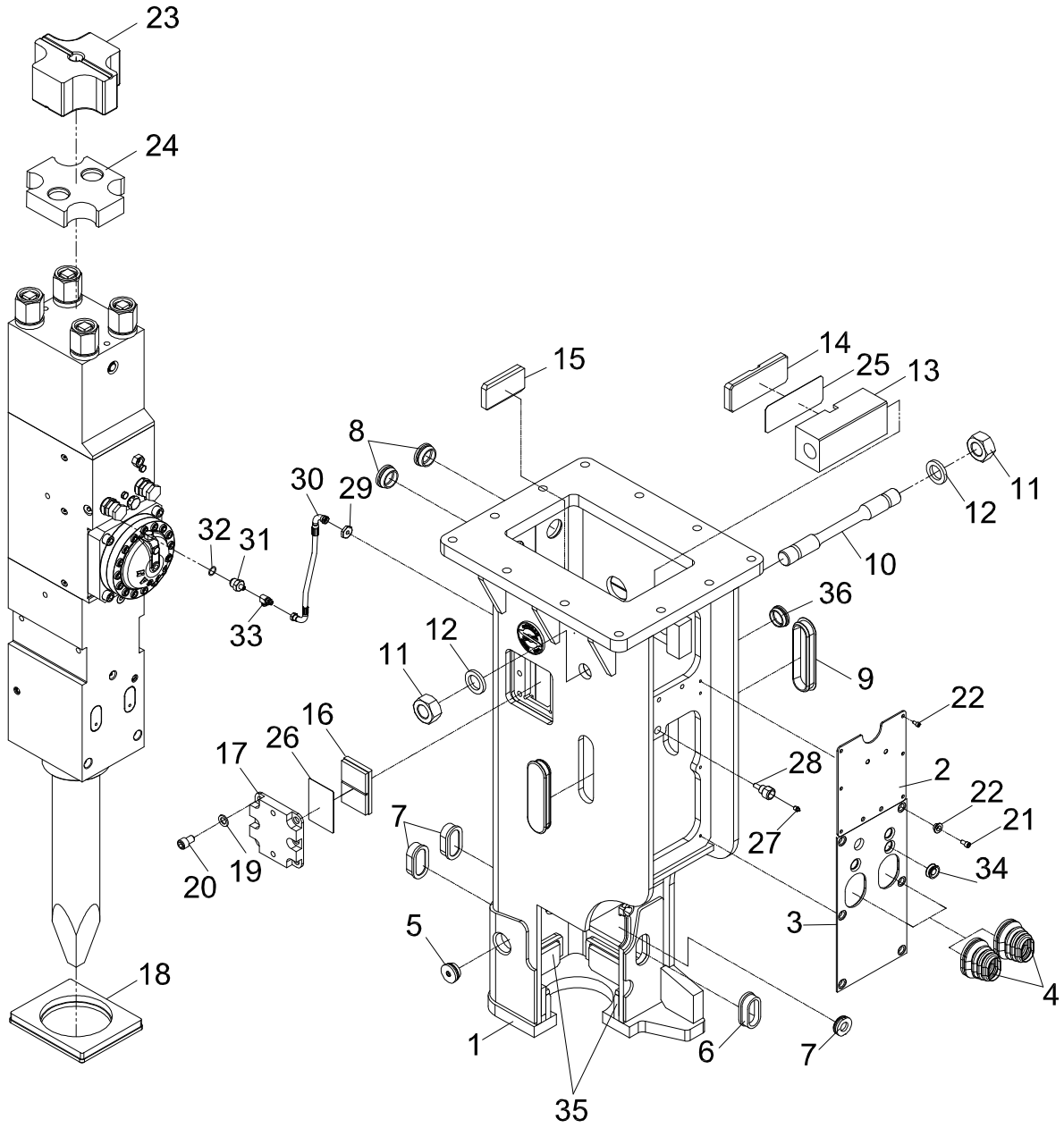

■ TS-P TYPE (SB147, 157)

NO	SB147 (#011~)		SB157 (#011~)		PARTS NAME	REMARK
	P/N	Q'ty	P/N	Q'ty		
	T53 002	1Set	T73 005	1Set	Frame Ass'y	
1	T53 105	1	T73 116	1	Frame	
2	L23 151	1	C73 355	1	Window Cover-H	
3	L23 263	1	C73 493	1	Window Cover-L	
4	D83 152	2	C72 478	2	Hose Cover	
5	C03 228	2	←	2	Pin Plug	
6	C63 211	4	←	4	Rod Plug	
7	L23 292	1	C03 360	1	Grease Plug	
8	C23 219	2	←	2	Check Plug	
9	C63 339	2	C73 267	2	Hose Plug	
10	L23 179	1	C73 368	1	Side Bolt	
11	C73 367	2	←	2	Side Nut	
12	C73 118	2	←	2	Washer	
13	C73 326	1	C73 599	1	Support Bar	
14	C73 327	1	←	1	Support Wear Plate	
15	C73 313	4	←	8	Inner Wear Plate	
16	C73 348	2	←	2	Side Wear Plate	
17	C73 366	2	←	2	W/P Holder	
18	L23 274	1	C73 546	1	Down Cushion	
19	4220008	12	←	12	Dish Spring Washer	
20	4011145	12	←	12	Socket Bolt	
21	4010060	10	←	12	Socket Bolt	
22	C03 282	10	←	12	Washer	
23	D83 258	1	C73 314	1	Upper Cushion	
24	L22 142	1	C73 320	1	Upper Cushion Guide	
25	C73 334	1	←	1	Support Shim	
26	D83 263	1	←	1	Wear Plate SHIM	
27	2700403	1	2700411	1	Grease Nipple	
28	E93 367	1	←	1	Grease Adapter	
29	E93 368	1	←	1	Nut	
30	E93 372	1	←	1	Oil Hose	
31	E93 366	1	←	1	Grease Adapter	
32	2851018	1	←	1	O-Ring	
33	C23 324	3	←	3	Window Plug	
34	C75 110	1	←	1	H&L Adapter	
35	E93 437	4	←	4	Inner Wear Plate(D/C)	
36	C73 217	1	←	1	Sound Plug	

09. Oil Hose

No	Parts Name	SB10 II	SB20 II	SB30 II	SB35 II	SB40 II	SB43 II	SB43B	SB45	SB50	SB60	Q'ty
		Parts No.	Parts No.	Parts No.	Parts No.	Parts No.	Parts No.	Parts No.	Parts No.	Parts No.	Parts No.	
1	Spring Hose	2614146	2614246	2614246	2614250	2614250	2614252	2631371	2611352	2611360	2610466	2
2	Hose Plug	E84 100	C04 100	C04 100	C04 100	C04 100	C14 100	C14 100	C14 100	C14 100	C34 100	1
3	O-ring	-	-	-	-	-	2856003	2856003	2856003	2856003	2856004	2

No	Parts Name	SB60	SB70 SB81N	SB81 SB81A	SB100 SB100II	SB121 SB130	SB140 SB147 SB147P	SB151 SB157 SB160	SB177	Q'ty
		Parts No.	Parts No.	Parts No.	Parts No.	Parts No.	Parts No.	Parts No.	Parts No.	
1	Spring Hose	2610466	2610466	←	2610470	2610571	←	←	←	2
2	Hose Plug	C34 100	C34 100	←	←	C64 100	←	←	←	1
3	O-ring	2856004	2856004	←	←	2856005	←	←	←	2

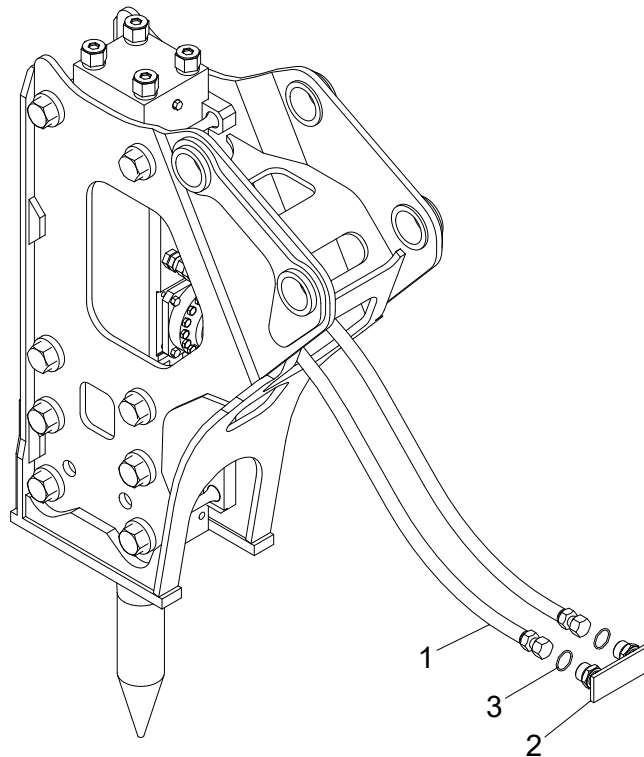

10. Tool set (Option)

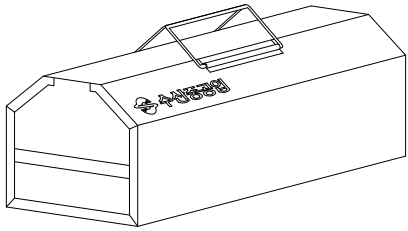

TOOL BOX

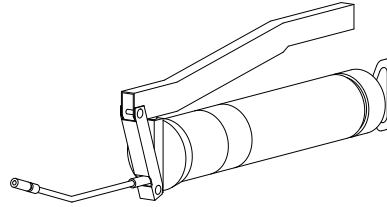

GREASE GUN

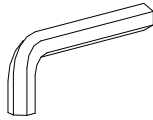

L- WRENCH

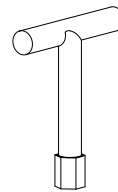

T - WRENCH



EYE BOLT

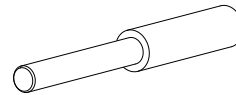

PIN BAR

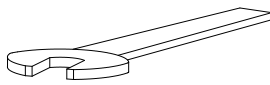

SINGLE SPANNER

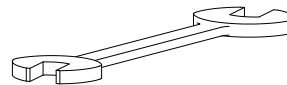

DOUBLE SPANNER

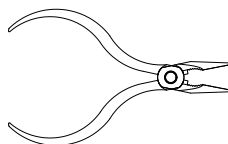

PLIERS

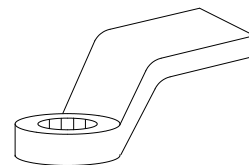

SINGLE RING SPANNER

■ Tool set (SIDE)

TOOL	Q'ty	SB10 II	SB20 II	SB30 II	SB35 II	SB40 II	SB43 II	SB45	SB50	SB60	SB70 SB81III	SB81	SB81A	SB100 SB100II	SB121	SB130	SB140~ SB177
Tool set	1	E81020	F01020	E71020	F81020	C01020	F91020	D41020	C11020	C21020	L01020	C31020	C31021	E91020	C61020	C61020	C71020
Tool box	1	8290002	8290002	8290002	8290002	8290002	8290002	8290002	8290002	8290003	8290003	8290003	8290003	8290003	8290003	8290003	8290003
Combination Spanner	1	-	27mm 8203161	30mm 8203162	30mm 8203162	-	-	-	-	-	-	-	-	-	-	-	-
D o u b l e spanner	1	-	-	-	-	27*30 8203060	27*30 8203060	27*30 8203060	27*30 8203060	27*30 8203060	27*30 8203060	27*30 8203060	27*30 8203060	27*30 8203060	27*30 8203060	27*30 8203060	27*30 8203060
D o u b l e spanner	1	22*24 8203057	-	-	-	-	22*24 8203057	22*24 8203057	22*24 8203057	22*24 8203057	22*24 8203057	22*24 8203057	22*24 8203057	22*24 8203057	22*24 8203057	22*24 8203057	22*24 8203057
Grease gun	1	300cc 8214002	300cc 8214002	300cc 8214002	300cc 8214002	300cc 8214002	300cc 8214002	300cc 8214002	300cc 8214002	300cc 8214002	300cc 8214002	300cc 8214002	300cc 8214002	300cc 8214002	300cc 8214002	300cc 8214002	300cc 8214002
L-Wrench	1	5mm 8202103	5mm 8202103	5mm 8202103	5mm 8202103	5mm 8202103	5mm 8202103	5mm 8202103	5mm 8202103	5mm 8202103	5mm 8202103	5mm 8202103	5mm 8202103	5mm 8202103	5mm 8202103	5mm 8202103	5mm 8202103
L-Wrench	1	-	-	-	-	-	-	8mm 8202105	8mm 8202105	8mm 8202105	8mm 8202105	8mm 8202105	8mm 8202105	8mm 8202105	12mm 8202107	12mm 8202107	12mm 8202107
L-Wrench	1	-	-	-	-	-	-	-	-	-	-	-	14mm 8202108	14mm 8202108	14mm 8202108	14mm 8202108	14mm 8202108
L-Wrench	1	-	-	-	-	-	-	-	-	-	-	-	17mm 8202110	17mm 8202110	17mm 8202110	17mm 8202110	19mm 8202111
Pin bar	1	D10 E71124	D10 E71124	D10 E71124	D13 F81131	D14 C01147	D14 C01147	D14 C01147	D14 C01147	D14 C01147	D14 C01147	D14 C01147	D14 C01147	D14 C01147	D14 C01147	D14 C01147	D14 C01147
SINGLE RING SPANNER	1	-	-	-	-	-	-	50mm C11154	55mm C11155	65mm C11157	70mm C11158	75mm C11159	75mm C11159	75mm C11159	75mm C11159	75mm C11159	85mm C11161
SINGLE RING SPANNER	1	-	-	-	-	-	-	-	-	-	-	-	-	-	85mm C11161	85mm C11161	-
S i n g l e spanner	1	27mm 8203012	30mm 8203013	27mm 8203012	27mm 8203012	13mm 8203003	41mm 8203018	36mm 8203016	36mm 8203016	36mm 8203016	36mm 8203016	-	-	36mm 8203016	32mm 8203014	32mm 8203014	36mm 8203016
S i n g l e spanner	1	30mm 8203013	-	36mm 8203016	36mm 8203016	41mm 8203018	46mm 8203019	46mm 8203019	-	41mm 8203018	41mm 8203018	41mm 8203018	41mm 8203018	41mm 8203018	46mm 8203019	46mm 8203019	46mm 8203019
S i n g l e spanner	1	-	-	-	-	-	-	-	-	46mm 8203019	46mm 8203019	-	-	46mm 8203019	50mm 8203020	50mm 8203020	50mm 8203020
S i n g l e spanner	1	-	-	-	-	-	-	-	-	-	-	50mm 8203020	50mm 8203020	50mm 8203020	55mm 8203021	55mm 8203021	55mm 8203021
Pliers	1	-	-	-	-	-	-	230mm 8204024	230mm 8204024	230mm 8204024	230mm 8204024	230mm 8204024	230mm 8204024	230mm 8204024	230mm 8204024	230mm 8204024	230mm 8204024
T-Wrench	1	14mm 8202131	14mm 8202131	14mm 8202131	14mm 8202131	14mm 8202131	14mm 8202131	14mm 8202131	14mm 8202131	14mm 8202131	14mm 8202131	14mm 8202131	14mm 8202131	14mm 8202131	14mm 8202131	14mm 8202131	14mm 8202131

■ Tool set (TOP)

TOOL	Q'ty	SB10 II	SB20 II	SB30 II	SB35 II	SB40 II	SB43 II	SB45	SB50
Tool set	1	E81022	F01023	E71022	F81022	C01023	F91023	D41024	C11027
Tool box	1	8290002	M 8290002	M 8290002	M 8290002	M 8290002	M 8290002	M 8290002	M 8290002
Combination Spanner	1	-	27mm 8203161	30mm 8203162	30mm 8203162	-	-	-	-
Double spanner	1	-	-	-	-	27*30 8203060	27*30 8203060	27*30 8203060	27*30 8203060
Double spanner	1	22*24 8203057	-	-	-	-	22*24 8203057	22*24 8203057	22*24 8203057
Grease gun	1	300cc 8214002	300cc 8214002	300cc 8214002	300cc 8214002	300cc 8214002	300cc 8214002	300cc 8214002	300cc 8214002
Long adapter		110mm F01137	110mm F01137	110mm F01137	110mm F01137	110mm F01137	110mm F01137	110mm F01137	110mm F01137
L-Wrench	1	5mm 8202103	5mm 8202103	5mm 8202103	5mm 8202103	5mm 8202103	5mm 8202103	5mm 8202103	5mm 8202103
L-Wrench	1	-	-	-	-	-	-	-	-
L-Wrench	1	-	-	-	-	-	-	-	-
L-Wrench	1	-	-	-	-	-	-	-	-
Pin bar	1	D10 E71124	D10 E71124	D10 E71124	D13 F81131	D14 C01147	D14 C01147	D14 C01147	D14 C01147
SINGLE RING SPANNER	1	-	-	-	-	-	-	50mm C11154	55mm C11155
SINGLE RING SPANNER	1	-	-	-	-	-	-	-	-
Single spanner	1	27mm 8203012	30mm 8203013	27mm 8203012	27mm 8203012	13mm 8203003	41mm 8203018	36mm 8203016	36mm 8203016
Single spanner	1	30mm 8203013	-	36mm 8203016	36mm 8203016	41mm 8203018	46mm 8203019	46mm 8203019	-
Single spanner	1	-	-	-	-	-	-	-	-
Single spanner	1	-	-	-	-	-	-	-	-
Single spanner	1	-	-	-	-	-	-	-	-
Pliers	1	-	-	-	-	-	-	230mm 8204024	230mm 8204024
T-Wrench	1	14mm 8202131	14mm 8202131	14mm 8202131	14mm 8202131	14mm 8202131	14mm 8202131	14mm 8202131	14mm 8202131

■ Tool set (TR-F, TS-P, BACK HOE SILENCE) - (#~) is applied Serial Number

TOOL	Qty	SB10 II	SB20 II	SB30 II	SB35 II	SB40 II	SB43 II	SB43B	SB45	SB50	SB60 (#2436~)	SB70(P) (#5219~)	SB81NP	SB81(P) (#10394~)	SB81A(P) (#6104~)	SB100 (#2182~)
Tool set	1	E81021	F01021	E71021	F81021	C01021	F91021	F91022	D41023	C11023	C21023	L01023	L01023	C31024	C31025	E91023
Tool box	1	M	M	M	M	M	M	M	M	M	L	L	L	L	L	L
Double spanner	1	8290002	8290002	8290002	8290002	8290002	8290002	8290002	8290002	8290003	8290003	8290003	8290003	8290003	8290003	8290003
Double spanner	1	22*24 8203057	-	-	-	22*24 8203057	22*24 8203057	22*24 8203057	22*24 8203057	22*24 8203057	22*24 8203057	22*24 8203057	22*24 8203057	22*24 8203057	22*24 8203057	22*24 8203057
Eye bolt	1	-	-	-	-	27*30 8203060	27*30 8203060	27*30 8203060	27*30 8203060	27*30 8203060	27*30 8203060	27*30 8203060	27*30 8203060	27*30 8203060	27*30 8203060	27*30 8203060
Eye bolt	1	M16 4020004	M16 4020004	M16 4020004	M16 4020004	M16 4020004	M16 4020004	M16 4020004	M16 4020004	M16 4020004	M16 4020004	M16 4020004	M16 4020004	M16 4020004	M16 4020004	M16 4020004
Eye bolt	2	M12 4020003	M12 4020003	M12 4020003	M12 4020003	M12 4020003	M12 4020003	M12 4020003	M20 4020005	M20 4020005	M24 4020006	M30 4020007	M30 4020007	M30 4020007	M30 4020007	M30 4020007
Grease gun	1	300cc 8214002	300cc 8214002	300cc 8214002	300cc 8214002	300cc 8214002	300cc 8214002	300cc 8214002	300cc 8214002	300cc 8214002	300cc 8214002	300cc 8214002	300cc 8214002	300cc 8214002	300cc 8214002	300cc 8214002
Long adapter	1	110mm F01137	110mm F01137	110mm F01137	110mm F01137	110mm F01137	110mm F01137	110mm F01137	110mm F01137	110mm F01137	110mm F01137	110mm F01137	110mm F01137	110mm F01137	110mm F01137	110mm F01137
L-Wrench	1	5mm 8202103	5mm 8202103	5mm 8202103	5mm 8202103	5mm 8202103	5mm 8202103	5mm 8202103	5mm 8202103	5mm 8202103	5mm 8202103	5mm 8202103	5mm 8202103	5mm 8202103	5mm 8202103	5mm 8202103
L-Wrench	1	-	-	-	-	-	-	-	-	-	-	-	-	-	-	-
L-Wrench	1	-	-	-	-	-	-	-	-	-	-	-	-	-	-	-
L-Wrench	1	8mm	8mm	8mm	8mm	8mm	8mm	8mm	8mm	8mm	8mm	8mm	8mm	8mm	8mm	8mm
Pin bar	1	D10 E71124	D10 E71124	D10 E71124	D13 F81 131	D14 C01147	D14 C01147	D14 C01147	D14 C01147	D14 C01147	D14 C01147	D14 C01147	D14 C01147	D14 C01147	D14 C01147	D14 C01147
Single ring Spanner	1	-	-	-	-	-	-	-	50mm C11154	55mm C11155	65mm C11157	70mm C11158	70mm C11158	75mm C11159	75mm C11159	75mm C11159
Single spanner	1	27mm 8203012	27mm 8203012	27mm 8203012	36mm 8203016	41mm 8203018	46mm 8203019	36mm 8203016	36mm 8203016	36mm 8203016	36mm 8203016	36mm 8203016	36mm 8203016	36mm 8203016	36mm 8203016	36mm 8203016
Single spanner	1	30mm 8203013	30mm 8203013	30mm 8203013	27mm 8203012	13mm 8203003	-	46mm 8203019	-	-	41mm 8203018	41mm 8203018	41mm 8203018	41mm 8203018	41mm 8203018	41mm 8203018
Single spanner	1	-	-	36mm 8203016	30mm 8203013	-	-	-	-	-	-	-	-	50mm 8203020	50mm 8203020	50mm 8203020
Single spanner	1	-	-	-	-	-	-	-	-	-	-	-	-	-	-	-
Pliers	1	-	-	-	-	-	-	-	230mm 8204024	230mm 8204024	230mm 8204024	230mm 8204024	230mm 8204024	230mm 8204024	230mm 8204024	230mm 8204024
T-Wrench	1	14mm 8202131	14mm 8202131	14mm 8202131	14mm 8202131	14mm 8202131	14mm 8202131	14mm 8202131	14mm 8202131	14mm 8202131	14mm 8202131	14mm 8202131	14mm 8202131	14mm 8202131	14mm 8202131	14mm 8202131

■ Tool set (TR-F, TS-P, BACK HOE SILENCE)

TOOL	Qty	SB10 II	SB20 II	SB30 II	SB35 II	SB40 II	SB43 II	SB43B	SB45	SB50	SB60 (#2436~)	SB70(P) (#5219~)	SB81NP	SB81(P) (#10394~)	SB81A(P) (#6104~)	SB100 (#2182~)	
Tool set	1	E81021	F01021	E71021	F81021	C01021	F91021	F91022	D41023	C11023	C21023	L01023	L01023	C31024	C31025	E91023	
Tool box	1	8290002	8290002	8290002	8290002	8290002	8290002	8290002	8290002	8290003	8290003	8290003	8290003	8290003	8290003	L	
Double spanner	1	22*24 8203057	-	-	-	-	22*24 8203057	22*24 8203057	22*24 8203057	22*24 8203057	22*24 8203057	22*24 8203057	22*24 8203057	22*24 8203057	22*24 8203057	22*24 8203057	22*24 8203057
Double spanner	1	-	-	-	-	27*30 8203060	27*30 8203060	27*30 8203060	27*30 8203060	27*30 8203060	27*30 8203060	27*30 8203060	27*30 8203060	27*30 8203060	27*30 8203060	27*30 8203060	27*30 8203060
Eye bolt	1	M16 4020004	M16 4020004	M16 4020004	M16 4020004	M16 4020004	M16 4020004	M16 4020004	-	-	-	M16 4020004	M16 4020004	M16 4020004	M16 4020004	M16 4020004	M16 4020004
Eye bolt	2	M12 4020003	M12 4020003	M12 4020003	M12 4020003	M12 4020003	M12 4020003	M12 4020003	M20 4020005	M20 4020005	M24 4020006	M30 4020007	M30 4020007	M30 4020007	M30 4020007	M30 4020007	M30 4020007
Grease gun	1	300cc 8214002	300cc 8214002	300cc 8214002	300cc 8214002	300cc 8214002	300cc 8214002	300cc 8214002	300cc 8214002	300cc 8214002	300cc 8214002	300cc 8214002	300cc 8214002	300cc 8214002	300cc 8214002	300cc 8214002	300cc 8214002
Long adapter	1	110mm F01137	110mm F01137	110mm F01137	110mm F01137	110mm F01137	110mm F01137	110mm F01137	110mm F01137	110mm F01137	110mm F01137	110mm F01137	110mm F01137	110mm F01137	110mm F01137	110mm F01137	110mm F01137
L-Wrench	1	5mm 8202103	5mm 8202103	5mm 8202103	5mm 8202103	5mm 8202103	5mm 8202103	5mm 8202103	5mm 8202103	5mm 8202103	5mm 8202103	5mm 8202103	5mm 8202103	5mm 8202103	5mm 8202103	5mm 8202103	5mm 8202103
L-Wrench	1	-	-	-	-	-	-	-	-	-	-	-	-	-	-	-	-
L-Wrench	1	-	-	-	-	-	-	-	-	-	-	-	-	-	-	-	-
L-Wrench	1	8mm	8mm	8mm	8mm	8mm	8mm	8mm	8mm	8mm	8mm	8mm	8mm	8mm	8mm	8mm	8mm
Pin bar	1	D10 E71124	D10 E71124	D10 E71124	D13 F81 131	D14 C01147	D14 C01147	D14 C01147	D14 C01147	D14 C01147	D14 C01147	D14 C01147	D14 C01147	D14 C01147	D14 C01147	D14 C01147	D14 C01147
Single ring Spanner	1	-	-	-	-	-	-	-	50mm C11154	55mm C11155	65mm C11157	70mm C11158	70mm C11158	75mm C11159	75mm C11159	75mm C11159	75mm C11159
Single spanner	1	27mm 8203012	27mm 8203012	27mm 8203012	36mm 8203016	41mm 8203018	46mm 8203019	36mm 8203016	36mm 8203016	36mm 8203016	36mm 8203016	36mm 8203016	36mm 8203016	36mm 8203016	36mm 8203016	36mm 8203016	36mm 8203016
Single spanner	1	30mm 8203013	30mm 8203013	30mm 8203013	27mm 8203012	13mm 8203003	-	46mm 8203019	-	-	41mm 8203018	41mm 8203018	41mm 8203018	41mm 8203018	41mm 8203018	41mm 8203018	41mm 8203018
Single spanner	1	-	-	36mm 8203016	30mm 8203013	-	-	-	-	-	-	-	-	-	-	-	-
Single spanner	1	-	-	-	-	-	-	-	-	-	-	-	-	-	-	-	-
Pliers	1	-	-	-	-	-	-	230mm 8204024	230mm 8204024	230mm 8204024	230mm 8204024	230mm 8204024	230mm 8204024	230mm 8204024	230mm 8204024	230mm 8204024	230mm 8204024
T-Wrench	1	14mm 8202131	14mm 8202131	14mm 8202131	14mm 8202131	14mm 8202131	14mm 8202131	14mm 8202131	14mm 8202131	14mm 8202131	14mm 8202131	14mm 8202131	14mm 8202131	14mm 8202131	14mm 8202131	14mm 8202131	14mm 8202131

■ Tool set (TR-F, TS-P, BACK HOE SILENCE)

TOOL	Qty	SB121 (#573~)	SB130 (#3462~)	SB140 (#1717~)	SB151 (#1183~)	SB81(P) (#10394~)	SB81A(P) (#6104~)	SB100 (#2182~)	SB121 (#573~)	SB130 (#3462~)	SB140 (#1717~)	SB151 (#1183~)	SB147P (#100~)	SB147 (#100~)	SB157 SB160 (#100~)	SB177	
Tool set	1	C61023	D81023	L21023	C71023	C31024	C31025	E91023	C61023	D81023	L21023	C71023	L2127	L2127	C71141	C71141	
Tool box	1	8290003	8290003	8290003	8290003	8290003	8290003	8290003	8290003	8290003	8290003	8290003	8290003	8290003	8290003	8290003	8290003
Double spanner	1	22*24 8203057	22*24 8203057	22*24 8203057	22*24 8203057	22*24 8203057	22*24 8203057	22*24 8203057	22*24 8203057	22*24 8203057	22*24 8203057	22*24 8203057	22*24 8203057	22*24 8203057	22*24 8203057	22*24 8203057	22*24 8203057
Double spanner	1	27*30 8203060	27*30 8203060	27*30 8203060	27*30 8203060	27*30 8203060	27*30 8203060	27*30 8203060	27*30 8203060	27*30 8203060	27*30 8203060	27*30 8203060	27*30 8203060	27*30 8203060	27*30 8203060	27*30 8203060	27*30 8203060
Eye bolt	1	M16 4020004	M16 4020004	M16 4020004	M16 4020004	M16 4020004	M16 4020004	M16 4020004	M16 4020004	M16 4020004	M16 4020004	M16 4020004	-	-	-	-	-
Eye bolt	2	M36 4020008	M36 4020008	M36 4020008	M42 4020009	M30 4020007	M30 4020007	M30 4020007	M36 4020008	M36 4020008	M36 4020008	M42 4020009	-	-	-	-	-
Grease gun	1	300cc 8214002	300cc 8214002	300cc 8214002	300cc 8214002	300cc 8214002	300cc 8214002	300cc 8214002	300cc 8214002	300cc 8214002	300cc 8214002	300cc 8214002	300cc 8214002	300cc 8214002	300cc 8214002	300cc 8214002	300cc 8214002
Long adapter	1	110mm F01137	110mm F01137	110mm F01137	110mm F01137	110mm F01137	110mm F01137	110mm F01137	110mm F01137	110mm F01137	110mm F01137	110mm F01137	-	-	-	-	-
L-Wrench	1	5mm 8202103	5mm 8202103	5mm 8202103	5mm 8202103	5mm 8202103	5mm 8202103	5mm 8202103	5mm 8202103	5mm 8202103	5mm 8202103	5mm 8202103	5mm 8202103	5mm 8202103	5mm 8202103	5mm 8202103	5mm 8202103
L-Wrench	1	14mm 8202108	14mm 8202108	17mm 8202110	17mm 8202110	14mm 8202108	14mm 8202108	14mm 8202108	14mm 8202108	14mm 8202108	14mm 8202108	17mm 8202110	8mm 8202105	8mm 8202105	8mm 8202105	8mm 8202105	8mm 8202105
L-Wrench	1	17mm 8202110	17mm 8202110	19mm 8202111	19mm 8202111	17mm 8202110	17mm 8202110	17mm 8202110	17mm 8202110	17mm 8202110	17mm 8202110	19mm 8202111	12mm 8202107	12mm 8202107	12mm 8202107	12mm 8202107	12mm 8202107
L-Wrench	1	12mm 8202107	12mm 8202107	12mm 8202107	12mm 8202107	-	-	-	12mm 8202107	12mm 8202107	12mm 8202107	12mm 8202107	17mm 8202110	17mm 8202110	17mm 8202110	17mm 8202110	17mm 8202110
L-Wrench	1	8mm 8202105	8mm 8202105	8mm 8202105	8mm 8202105	8mm 8202105	8mm 8202105	8mm 8202105	8mm 8202105	8mm 8202105	8mm 8202105	8mm 8202105	19mm 8202111	19mm 8202111	22mm 8202112	22mm 8202112	22mm 8202112
Pin bar	1	C01147	C01147	C01147	C01147	D14	D14	D14	D14	D14	D14	D14	D14	D14	D14	D14	D14
Single ring Spanner	1	75mm C11159	75mm C11159	85mm C11161	85mm C11161	75mm C11159	75mm C11159	75mm C11159	75mm C11159	75mm C11159	85mm C11161	85mm C11161	85mm C11161	85mm C11161	85mm C11161	85mm C11161	85mm C11161
Single spanner	1	32mm 8203014	32mm 8203014	36mm 8203016	36mm 8203016	36mm 8203016	36mm 8203016	36mm 8203016	32mm 8203014	32mm 8203014	36mm 8203016	36mm 8203016	36mm 8203016	36mm 8203016	36mm 8203016	36mm 8203016	36mm 8203016
Single spanner	1	36mm 8203016	46mm 8203019	46mm 8203019	46mm 8203019	41mm 8203018	41mm 8203018	41mm 8203018	36mm 8203016	46mm 8203019	46mm 8203019	46mm 8203019	46mm 8203019	46mm 8203019	46mm 8203019	46mm 8203019	46mm 8203019
Single spanner	1	50mm 8203020	50mm 8203020	50mm 8203020	50mm 8203020	50mm 8203020	50mm 8203020	50mm 8203020	50mm 8203020	50mm 8203020	50mm 8203020	50mm 8203020	50mm 8203020	50mm 8203020	50mm 8203020	50mm 8203020	50mm 8203020
Single spanner	1	55mm 8203021	55mm 8203021	55mm 8203021	55mm 8203021	-	-	-	55mm 8203021	55mm 8203021	55mm 8203021	55mm 8203021	55mm 8203021	55mm 8203021	55mm 8203021	55mm 8203021	55mm 8203021
Pliers	1	230mm 8204024	230mm 8204024	230mm 8204024	230mm 8204024	230mm 8204024	230mm 8204024	230mm 8204024	230mm 8204024	230mm 8204024	230mm 8204024	230mm 8204024	230mm 8204024	230mm 8204024	230mm 8204024	230mm 8204024	230mm 8204024
T-Wrench	1	14mm 8202131	14mm 8202131	14mm 8202131	14mm 8202131	14mm 8202131	14mm 8202131	14mm 8202131	14mm 8202131	14mm 8202131	14mm 8202131	14mm 8202131	14mm 8202131	14mm 8202131	14mm 8202131	14mm 8202131	14mm 8202131

11. Back head gas charging kit (Option)

11.1 Back head gas charging kit 1(SB10 II ~ SB50)

NO	PARTS No.	Q'ty	PARTS NAME
	C01 272	1Set	N ₂ (Nitrogen) Gas charging set
1	2900013	1	N ₂ Gas cylinder
2	2651001	1	Synflex hose
3	C01 244	1	3 – Way valve assembly
4	C91 122	1	Bombe adapter
5	C91 121	1	Bombe adapter nut

11.2 Back head gas charging kit 2(SB60 ~ SB195H)

NO	PARTS No.	Q'ty	PARTS NAME
	C61 204	1Set	N ₂ Gas charging set
1	2900003	1	N ₂ Gas cylinder
2	2651001	1	Synflex hose
3	C01 244	1	B-3Way valve assembly
4	C91 122	1	Bombe adapter
5	C91 121	1	Bombe adapter nut

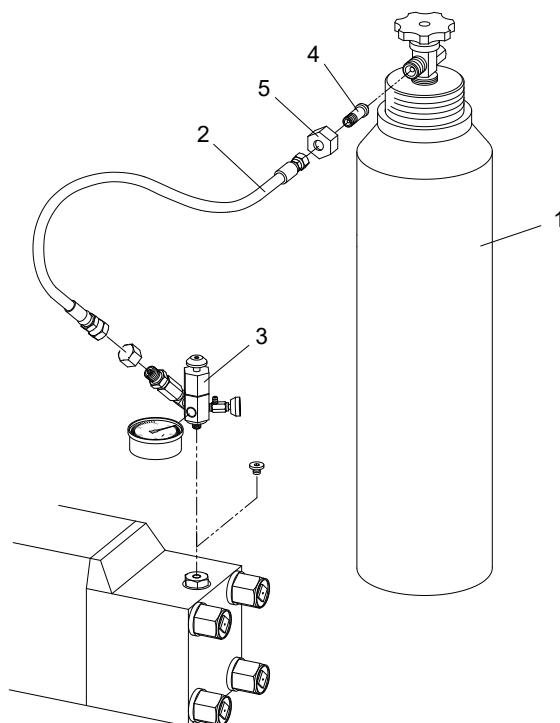

12. Accumulator charging tool set (Option)

NO	PARTS No.	Q'ty	PARTS NAME
	C61 205	1Set	Accumulator gas charging set
1	C61 204	1Set	N ₂ Gas charging set
2	U81 414	1	Hex bushing
3	2850014	1	O-RING

